



Dear Customer,

Our compliments for having chosen a top-quality Immergas product, able to assure well-being and safety for a long period of time. As an Immergas customer you can also count on a qualified after-sales service, prepared and updated to guarantee constant efficiency of your products. Read the following pages carefully: you will be able to draw useful suggestions regarding the correct use of the appliance, the respect of which, will confirm your satisfaction for the Immergas product.

For assistance and scheduled maintenance contact Authorised Immergas After-Sales centres: they have original spare parts and are specifically trained directly by the manufacturer.

General recommendations

All Immergas products are protected with suitable transport packaging.

The material must be stored in dry environments protected against bad weather.

The instruction book is an integral and essential part of the product and must be consigned to the new user also in the case of transfer or succession of ownership.

It must be stored with care and consulted carefully, as all of the warnings provide important safety indications for installation, use and maintenance stages.

This instructions manual provides technical information for installing Immergas appliances. As for the other issues related to the installation of appliances (e.g. safety in the work site, environment protection, injury prevention), it is necessary to comply with the provisions of the regulations in force and the principles of good practice.

In compliance with legislation in force, the systems must be designed by qualified professionals, within the dimensional limits established by the Law. Installation and maintenance must be performed in compliance with the regulations in force, according to the manufacturer's instructions and by professionally qualified staff, intending staff with specific technical skills in the plant sector, as envisioned by the Law.

Improper installation or assembly of the Immergas appliance and/or components, accessories, kit and devices can cause unexpected problems to people, animals and objects. Read the instructions provided with the product carefully to ensure a proper installation.

Maintenance must be carried out by skilled technical staff. The Authorised After-sales Service represents a guarantee of qualifications and professionalism.

The appliance must only be destined for the use for which it has been expressly declared. Any other use will be considered improper and therefore potentially dangerous.

If errors occur during installation, operation and maintenance, due to non compliance with technical laws in force, standards or instructions contained in this book (or however supplied by the manufacturer), the manufacturer is excluded from any contractual and extra-contractual liability for any damages and the appliance warranty is invalidated.

The company **IMMERGAS S.p.A.**, with registered office in via Cisa Ligure 95 42041 Brescello (RE), declares that the design, manufacturing and after-sales assistance processes comply with the requirements of standard **UNI EN ISO 9002:2015**.

For further details on the product CE marking, request a copy of the Declaration of Conformity from the manufacturer, specifying the appliance model and the language of the country.

The manufacturer declines all liability due to printing or transcription errors, reserving the right to make any modifications to its technical and commercial documents without forewarning.



INDEX

1	Installing the device	5	3	Checks and maintenance	13
1.1	Description of the device.....	5	3.1	Wiring diagram - Boiler connection using 3-relay board.	13
1.2	Installation recommendations.....	5	3.2	Wiring diagram - Boiler connection using 1-relay board.	14
1.3	Main dimensions.	6	3.3	Wiring diagram - Boiler connection using external relay.....	15
1.4	Hydraulic connection.	7	3.4	Wiring diagram - connection to multi-zone P.C.B. kit. ..	16
1.5	Electrical connection.	7	3.5	Wiring diagram connection to Victrix Maior, Extra, Intec V2 series boiler via multifunction relay.....	17
1.6	ErP DIM Base installation diagram	8	3.6	Troubleshooting.....	17
1.7	Circulation pump.	9			
The boiler is supplied with pump fitted with speed regulator. ...		9	4	Technical data	18
1.8	Main components.....	11			
1.9	Sizing the systems.....	11			
1.10	Commissioning the device.....	11			
1.11	Kits available on request.	11			
2	Use and maintenance instructions	12			
2.1	General warnings.	12			
2.2	Warnings for the user.....	12			
2.3	Cleaning the case.....	12			



1 INSTALLING THE DEVICE

1.1 DESCRIPTION OF THE DEVICE.

The abbreviation “D.I.M.” (Disgiuntore Idrico Multi-impianti - multi-system distribution manifold) identifies a series of kits that Immergas has designed for the management of central heating systems with large water capacities. In particular, they are kits that can only be coupled with some boiler models in the Immergas range, including an open manifold (distribution manifold) and a circulator.

IMPORTANT: the boiler models set-up for coupling with the manifolds are Immergas boilers with P.C.B. designed for the management of zone systems.

These kits are characterised by the possibility to be recessed in the wall, therefore have no clearance.

The zone served by the distribution manifold is managed by an Immergas chrono-thermostat connected to the boiler.

1.2 INSTALLATION RECOMMENDATIONS.

The place of installation of the appliance and relative Immergas accessories must have suitable features (technical and structural) such to allow (always in safety, efficiency and comfortable conditions):

- installation (according to the provisions of the technical legislation and technical regulations);
- maintenance operations (including scheduled, periodic, routine and special maintenance);
- removal (to outdoors in the place for loading and transporting the appliances and components) as well as their eventual replacement with appliances and/or equivalent components.

Only professionally qualified companies are authorised to install the Immergas Multi-System Distribution Manifold. Installation must be carried out according to regulation standards, current legislation and in compliance with local technical regulations and the required technical procedures. Before installing the device, ensure that it is delivered in perfect condition; if in doubt, contact the supplier immediately. Packing materials (staples, nails, plastic bags, polystyrene foam, etc.) constitute a hazard and must be kept out of the reach of children. In the event of malfunctions, faults or incorrect operation, turn the device off immediately and contact an authorised company (e.g. the Authorised Technical Assistance centre, which has specifically trained staff and original spare parts). Do not attempt to modify or repair the appliance alone. Failure to comply with the above implies personal responsibility and invalidates the warranty.

Recess installation.

Do the masonry work creating an opening in the wall suitable to contain the device (See parag. “Main dimensions”).

Insert the distribution manifold (1) in its seat, remembering to open the four support fins (2) before inserting it (Fig. 1).

Protect the side edges and the front cover during the recess preparation for the device.

IMPORTANT: the hydraulic and electrical connections must be made within the device unit; you must therefore position the frame first and then perform the connections.

Attention: the recessed frame is not a supporting structure and cannot replace the piece of wall removed. It is therefore necessary to check the correct positioning inside the wall.

Wall-hanging installation.

Fasten the frame to the wall using four expansion plugs suitable for the type of wall and weight of the device (not supplied) and using the four drilled holes (see Fig. 2 pos. X).

Use the fairlead and the sheath-holder (3) supplied to limit the infiltration of water inside the frame.

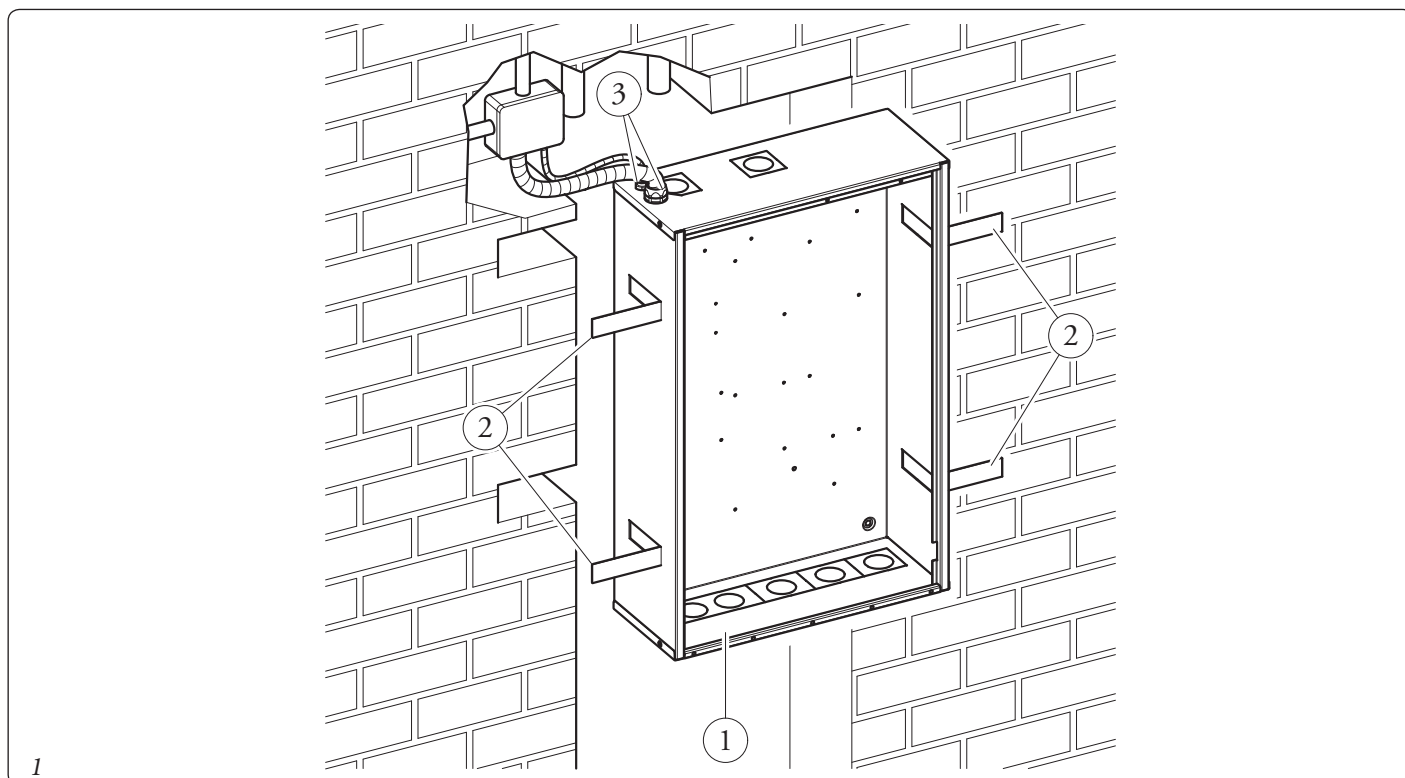

1.3 MAIN DIMENSIONS.

2

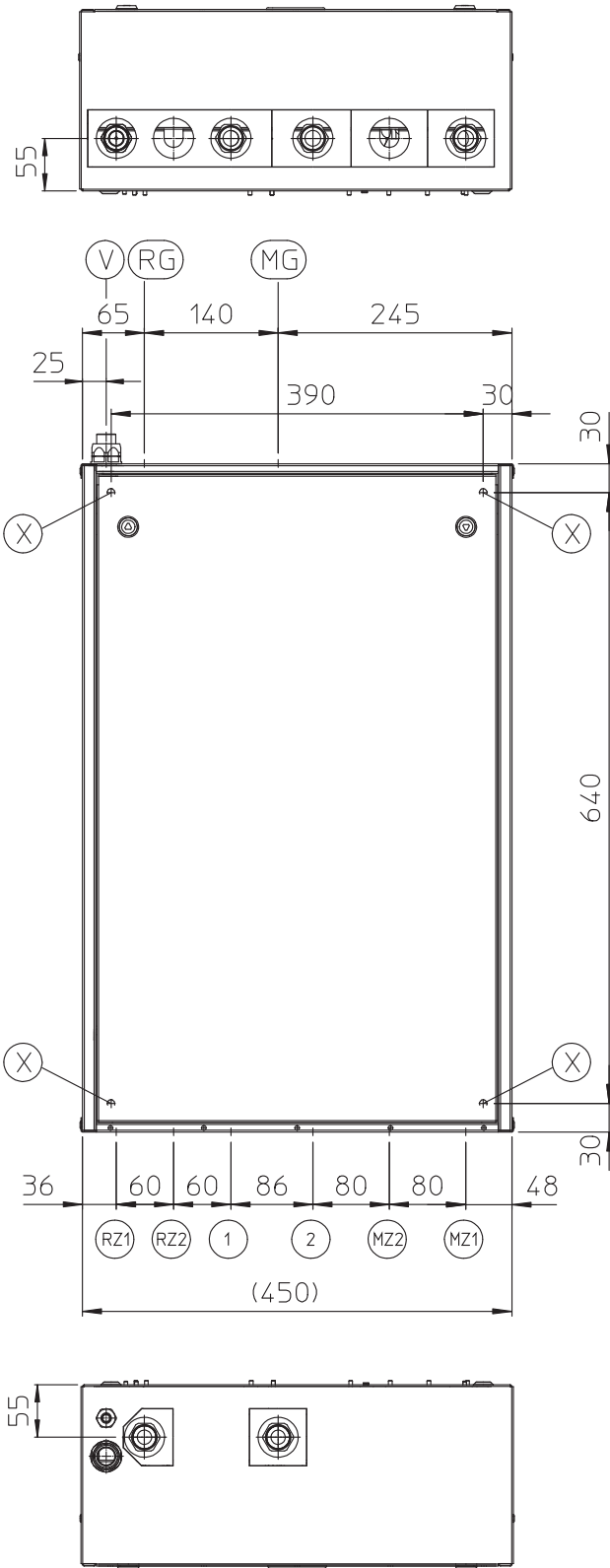

Height (mm)	Width (mm)	Depth (mm)
700	450	190

Key:
 RG - Generator return (G 3/4")
 MG - Generator flow (G 3/4")
 V - Electrical connection
 X - Holes for DIM wall-mounted fastening

ErP DIM Base
 RZ1 - System return (G 3/4")
 MZ1 - System flow (G 3/4")

Connections RZ2, 1, 2, MZ2 are not used on this model.

1.4 HYDRAULIC CONNECTION.

Attention: before making the appliance connections, clean the heating system thoroughly (pipes, radiators, etc.) with special pickling or de-scaling products to remove any deposits that could compromise correct device operation.

A chemical treatment of the thermal system water is required, in compliance with the technical standards in force, in order to protect the system and the appliance from deposits (e.g., lime scale), slurry or other hazardous deposits.

The hydraulic connections must be made in a rational manner using the values as per Fig. 2.

IMPORTANT: remove all the protection caps from the system flow and return pipes before making the hydraulic connections. The connections can be made directly using the female couplings on the distribution manifold or by inserting system cut-off cocks (optional). These cocks are particularly useful for maintenance as they allow you to drain the distribution manifold separately without having to empty the entire system.

N.B.: Immergas does not supply the G1” cocks to be installed in the low temperature zone.

Check that the expansion vessel present in the boiler, is sufficient to allow the increase in volume of the water and consequently its heating without causing the safety valve to open. If this is not the case, an expansion vessel with appropriately dimensioned capacity must be installed on the system.

The D.I.M. is set-up for the insertion of the automatic “jolly” vent valve to be mounted on the manifold. This is recommended for better air venting inside the system.

If two D.I.M devices are installed in parallel, two manual valves must be fitted in order to ensure the correct balance of the hydraulic circuit.

1.5 ELECTRICAL CONNECTION.

The appliance has an IPX5D protection degree, electrical safety of the appliance is reached only when it is connected properly to an efficient earthing system as specified by current safety standards.

Attention: the manufacturer declines any responsibility for damage or physical injury caused by failure to connect the boiler to an efficient earth system or failure to comply with the reference standards.

Also ensure that the electrical installation corresponds to maximum absorbed power specifications as shown on the recessed unit data-plate. The distribution manifold is supplied complete with an “X” type power cable without plug. The power supply cable must be connected to a 230V \pm 10% / 50Hz mains supply respecting L-N polarity and earth connection;  this network must also have a multi-pole circuit breaker with class III over-voltage category. To protect from possible dispersions of DC voltage one must provide a type A differential safety device.

When replacing the power supply cable, contact a qualified firm (e.g. the Authorised After-Sales Technical Assistance Service). For the main power supply to the appliance, never use adapters, multiple sockets or extension leads.

Important: it is mandatory to prepare two electrical connection lines in order to separate the power supply of each distribution manifold from all other low voltage connections according to the Standards in force regarding electrical systems. These lines must arrive inside the recessed frame via relevant sheaths or ducts passing through the fairlead and the sheath-holder supplied, located on the upper side of the device.

• **Connecting the boiler P.C.B.** It allows the DIM BASE operation to be managed via the boiler settings and commands. Perform the connections as described in chapter 3.

N.B.: the electrical connection between the devices must be made using cables with a minimum section of 0.50 mm² and with a maximum section of 2.5 mm².



1.6 ERP DIM BASE INSTALLATION DIAGRAM.

Fig. 3 displays the indicative installation diagram. Refer to the wiring diagrams in the following paragraphs for pump management options and related electrical connections.

Note: it may be necessary to install an interface device (optional).

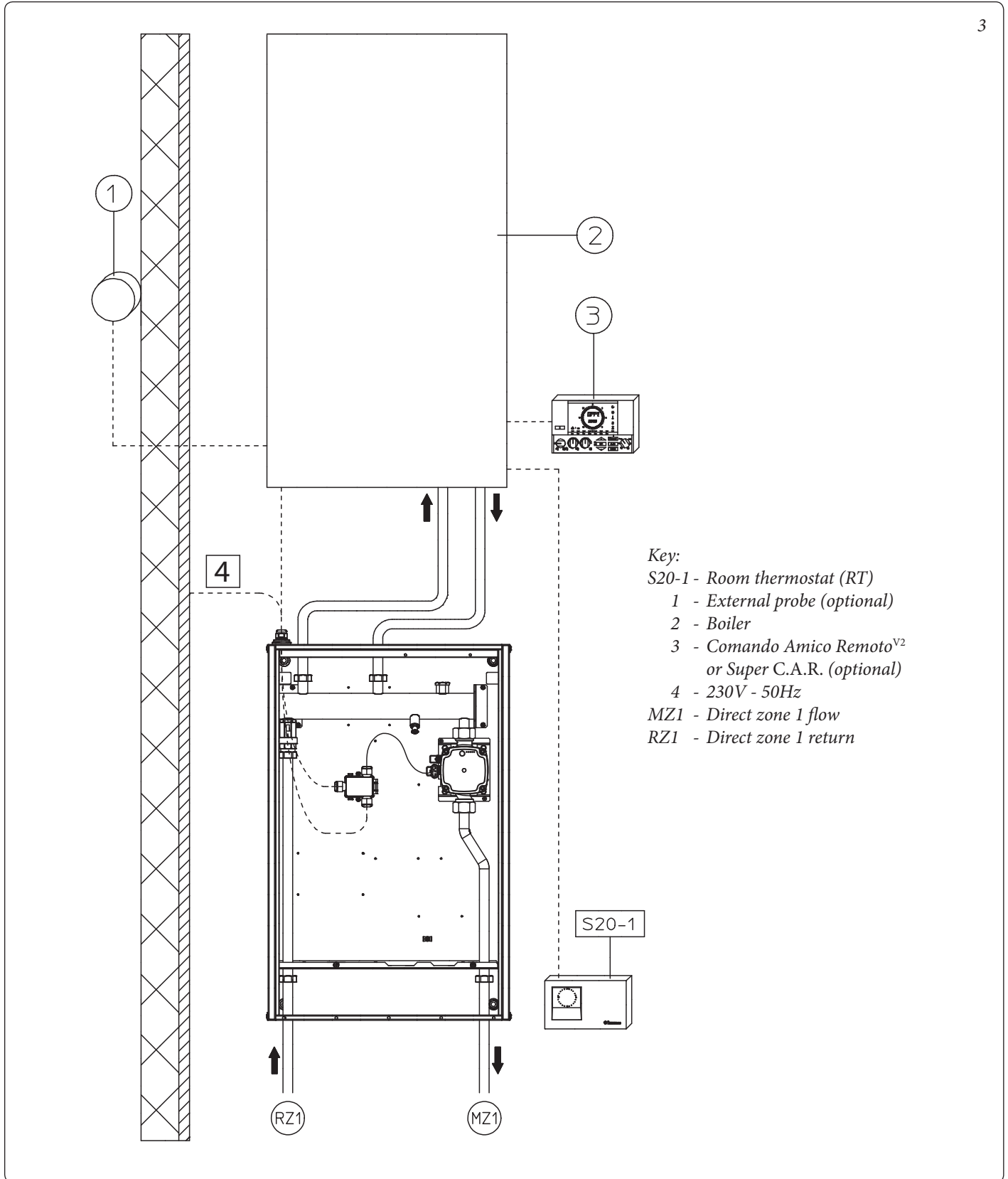

1.7 CIRCULATION PUMP.

The boiler is supplied with pump fitted with speed regulator. These settings are suitable for most systems.

In fact, the pump is equipped with electronic control to set advanced functions. For proper operation one must select the most suitable type of operation for the system and select a speed in the available range, with a focus on energy savings.

Selection of operating mode.

When running, the pump indicates the set configuration by means of the codified lighting of the LEDs. The setting is changed by a short pressing of the button.

Attention: The pump has various built-in operating modes, however the constant curve operating mode must be selected according to the following table.

Circulating pump LED	Description
G G Y Y Y ● ○ ● ○ ○	Do not use
G G Y Y Y ● ○ ● ● ○	Do not use
G G Y Y Y ● ○ ● ● ●	Do not use
G G Y Y Y ○ ● ● ○ ○	Do not use
G G Y Y Y ○ ● ● ● ○	Do not use
G G Y Y Y ○ ● ● ● ●	Do not use
G G Y Y Y ○ ○ ● ○ ○	Constant curve speed 1
G G Y Y Y ○ ○ ● ● ○	Constant curve speed 2
G G Y Y Y ○ ○ ● ● ●	Constant curve speed 3

Constant curve: the pump operates maintaining constant speed.

The pump is set at “Constant curve speed 2” by default.

Real time diagnostics: in the event of malfunction the LEDs provide information on the pump operation status, see table (Fig. 5):

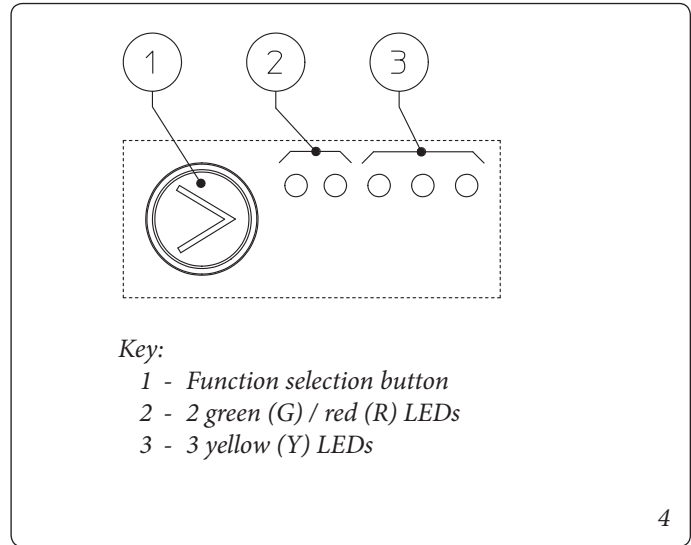

5

Circulating pump LED (first red LED)	Description	Diagnostics	Remedy
R Y Y Y Y ● ○ ○ ○ ●	Pump blocked mechanically	The pump cannot restart automatically due to an anomaly	Wait for the pump to make automatic release attempts or manually release the motor shaft acting on the screw in the centre of the head. If the anomaly persists replace the pump.
R Y Y Y Y ● ○ ○ ● ○	Abnormal situation (the pump continues operating). low power supply voltage	Voltage off range < 160 Vac	Check power supply
R Y Y Y Y ● ○ ● ○ ○	Electrical fault (Pump blocked)	The pump is locked due to power supply too low or serious malfunction	Check the power supply if the anomaly persists replace the pump



Head available to the system.

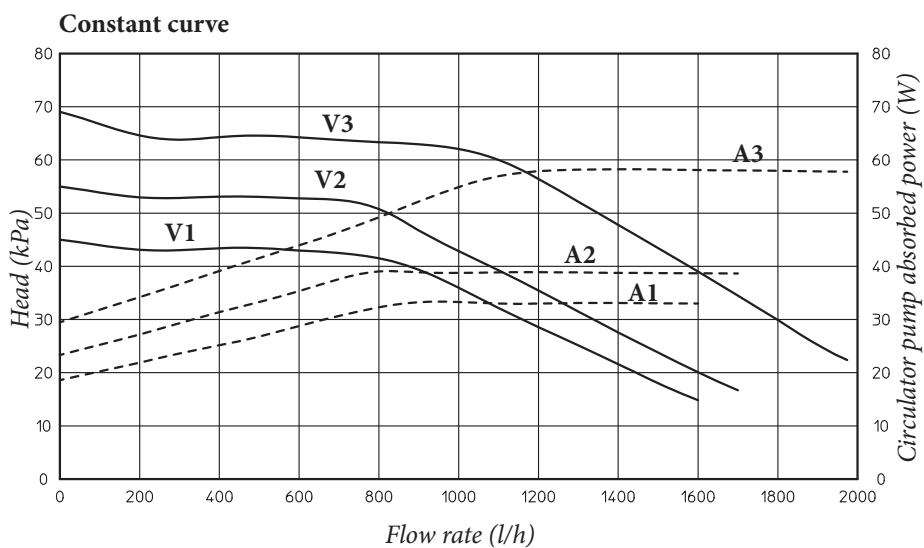
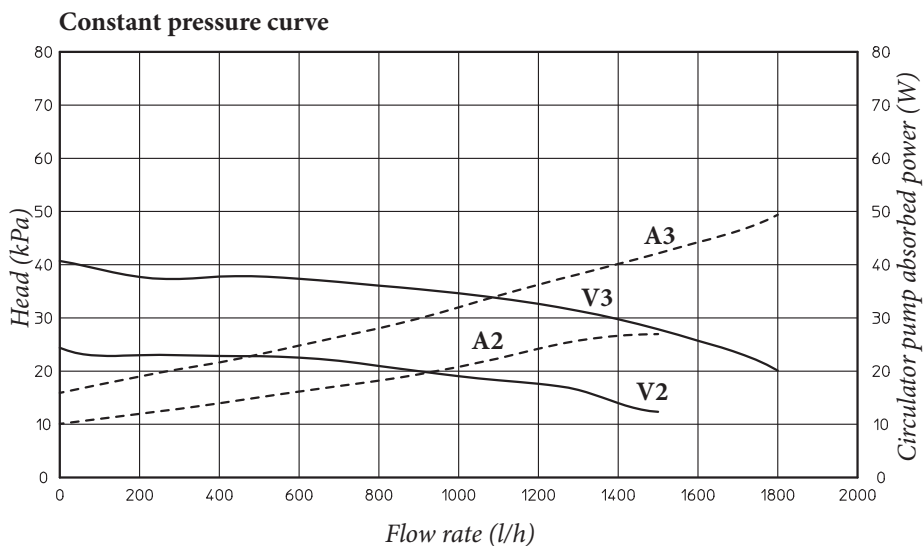
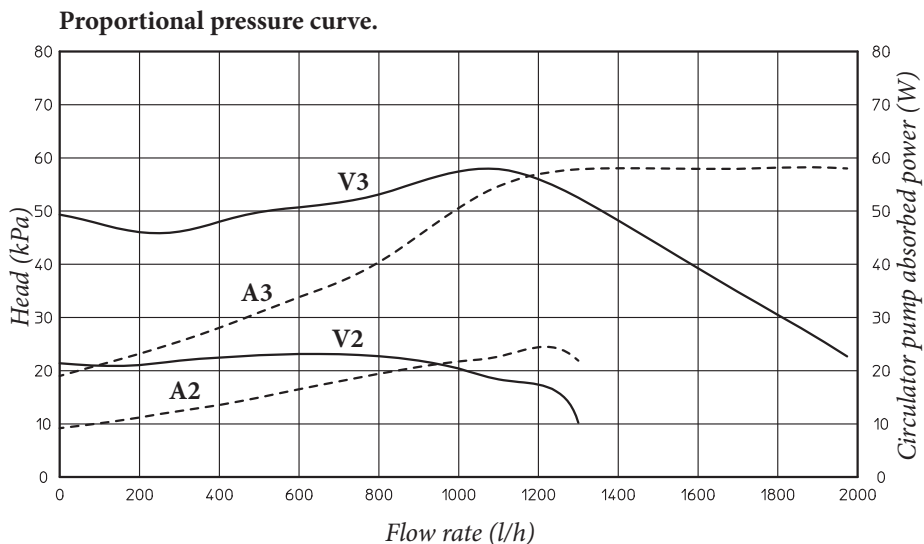

Key:
V_n = Available head
A_n = Circulating pump absorbed power



1.8 MAIN COMPONENTS.

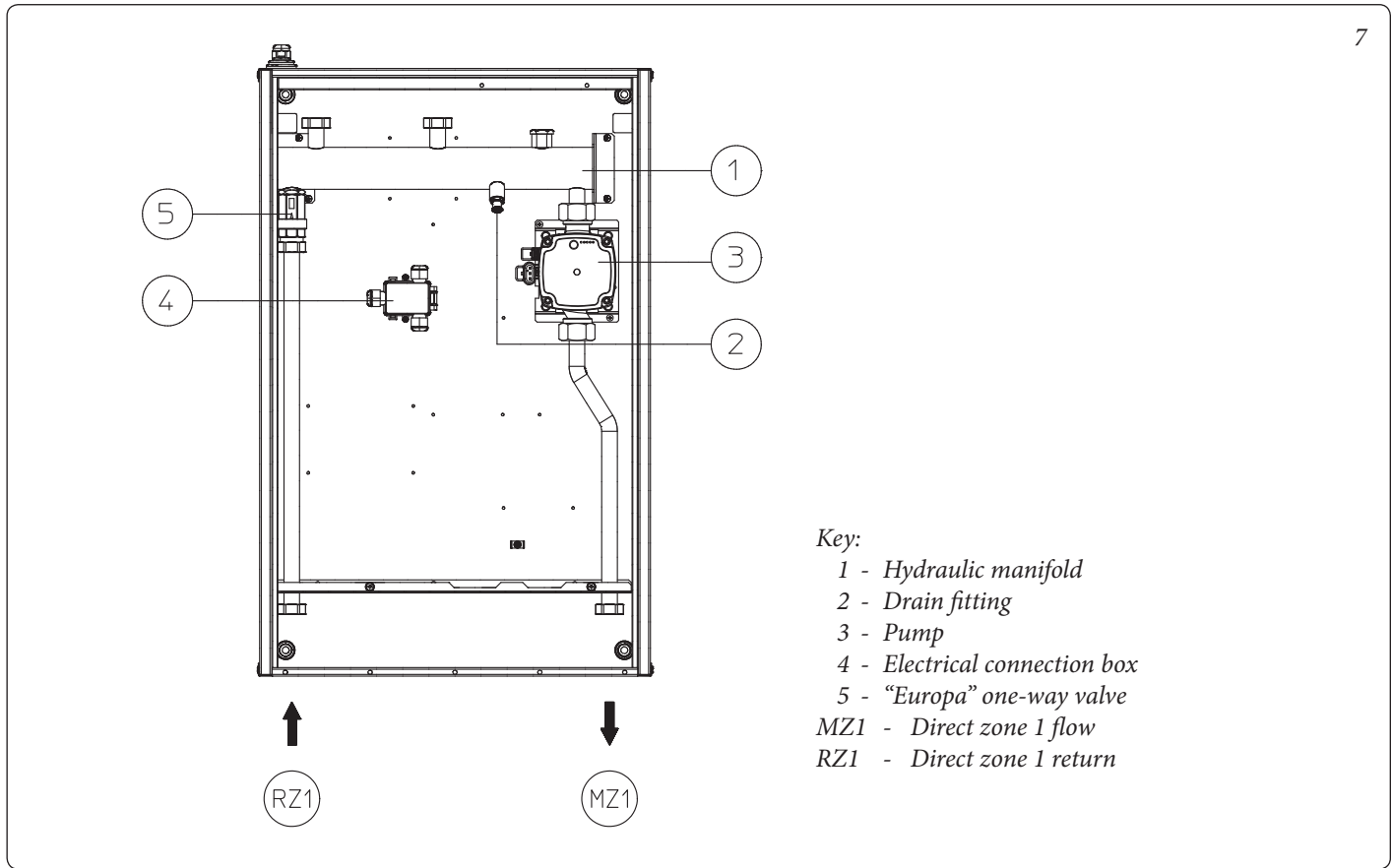

1.9 SIZING THE SYSTEMS.

The flow temperatures to the various system zones may be reduced compared to the boiler outlet temperatures, according to the mixture of the flow and return fluids inside the DIM. In the event that the DIM is used to feed Low Temperature zones, check that the design parameters allow you to achieve a maximum surface temperature of the radiant floor in compliance with standard UNI EN 1264.

1.10 COMMISSIONING THE DEVICE.

System filling. Once the device is connected, fill the system via the boiler filling valve.

Filling is performed at low speed to ensure release of air bubbles in the water via the boiler and central heating system vents and of the distribution manifold (if any).

Close radiator vent valves when only water escapes from them.

Close the filling cock when the boiler pressure gauge indicates approx. 1.2 bar.

N.B.: during these operations, start the circulation pump by actuating the main switch on the boiler control panel after having activated the RT.

1.11 KITS AVAILABLE ON REQUEST.

- System cut-off cock kit (on request). The manifold is designed for installation of system interception cocks to be placed on flow and return pipes of the connection assembly. This kit is particularly useful for maintenance as it allows the DIM to be drained separately without having to empty the entire system.

The above-mentioned kits are supplied complete with instructions for assembly and use.

2 USE AND MAINTENANCE INSTRUCTIONS

2.1 GENERAL WARNINGS.

If the device must be deactivated temporarily, act directly on the main switch to remove voltage from the system and work safely

- **Attention:** using any components that use electrical power requires some fundamental rules to be observed:
 - do not touch the device with wet or moist parts of the body; do not touch when barefoot.
 - if the device is wall-mounted: do not pull the electric cables, do not leave the device exposed to the elements (rain, sun, etc.);
 - the device power cable must not be replaced by the user;
 - in the event of damage to the cable, switch the device off and contact exclusively professionally qualified staff for replacement;
 - if the device is not going to be used for a certain period, disconnect the main power switch.

2.2 WARNINGS FOR THE USER.

This device does not require any regulation or control by the user. *It is therefore prohibited to open the device front lid.*

The only operation that the user must perform is to periodically check the water pressure of the system in the boiler. The boiler pressure gauge should read a value between 1 and 1.2 bar.

If the pressure is below 1 bar (with the circuit cool) restore normal pressure via the filling valve located in the boiler (see boiler instruction book).

N.B.: close the valve after the operation.

If pressure values reach around 3 bar, the boiler safety valve may be activated.

In this case, remove water from an air vent valve of a radiator until reaching pressure of 1 bar, or ask for assistance from professionally qualified personnel.

In the event of frequent pressure drops, contact qualified staff for assistance to eliminate any system leakage.

At the end of its service life the appliance must not be disposed of like normal household waste nor abandoned in the environment, but must be removed by a professionally authorised company. Contact the manufacturer for disposal instructions.

2.3 CLEANING THE CASE.

Use damp cloths and neutral detergent to clean the manifold casing. Never use abrasive or powder detergents.



3 CHECKS AND MAINTENANCE

- Check connection to a 230V-50Hz power mains via an omni-polar disconnector (magnetothermal circuit breaker), correct L-N polarity and the earthing connection;
- check that the magnetothermal circuit breaker is working properly;
- make sure the central heating system is filled with water and that the pressure gauge indicates a pressure of 1±1.2 bar.

- make sure that the air valve cap (if present) is open and that the system is well deaerated;
- check sealing efficiency of water circuits;
- check the correlation between the electric and hydraulic connections;

If even only a single safety check offers a negative result, do not commission the system.

3.1 WIRING DIAGRAM - BOILER CONNECTION USING 3-RELAY BOARD.

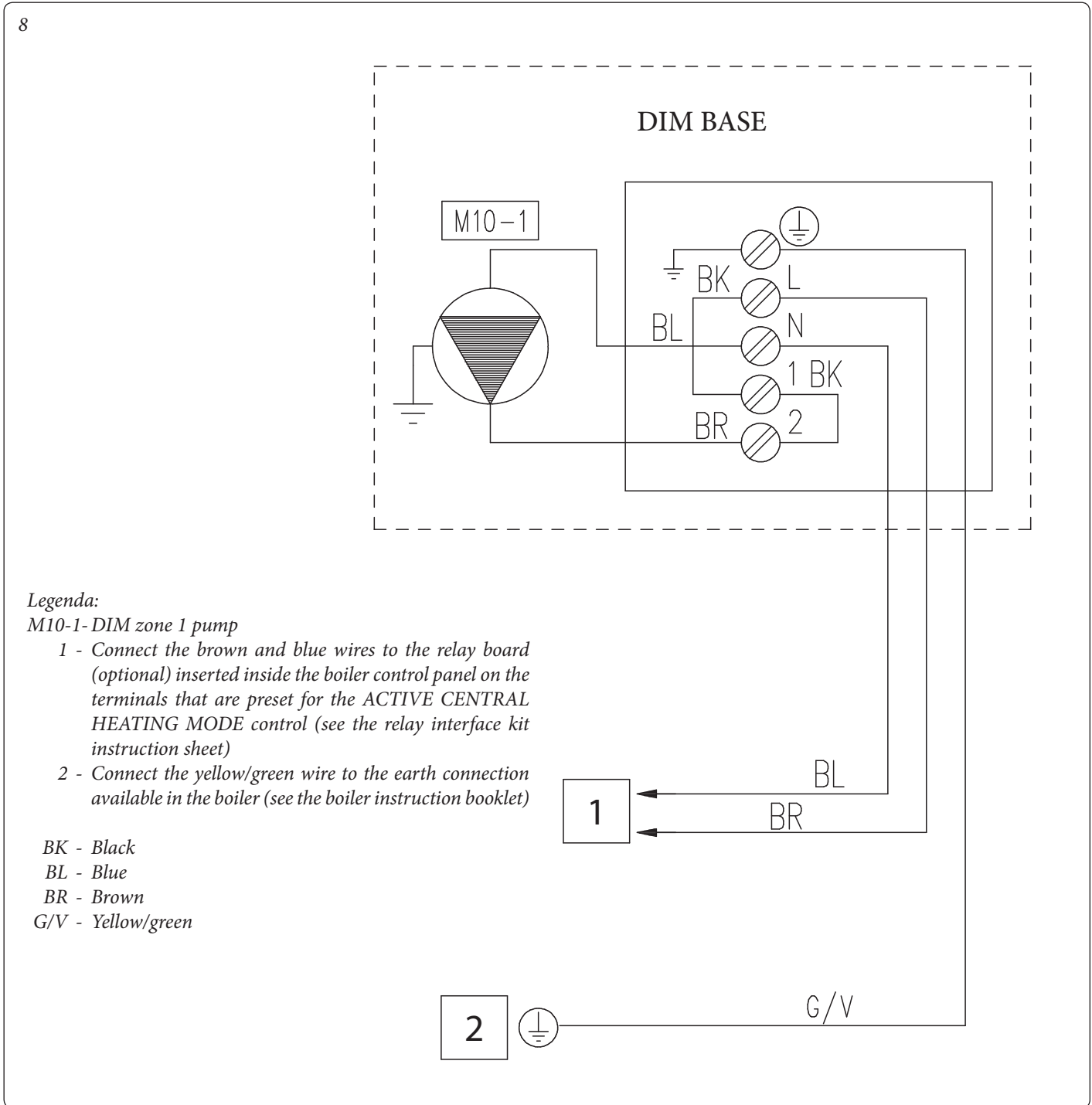

If a remote control or zone control room thermostat is used, its electric connection must be made directly to the boiler, as de-

scribed in the relative instruction book.

INSTALLER

USER

MAINTENANCE TECHNICIAN

TECHNICAL DATA



3.2 WIRING DIAGRAM - BOILER CONNECTION USING 1-RELAY BOARD.

9

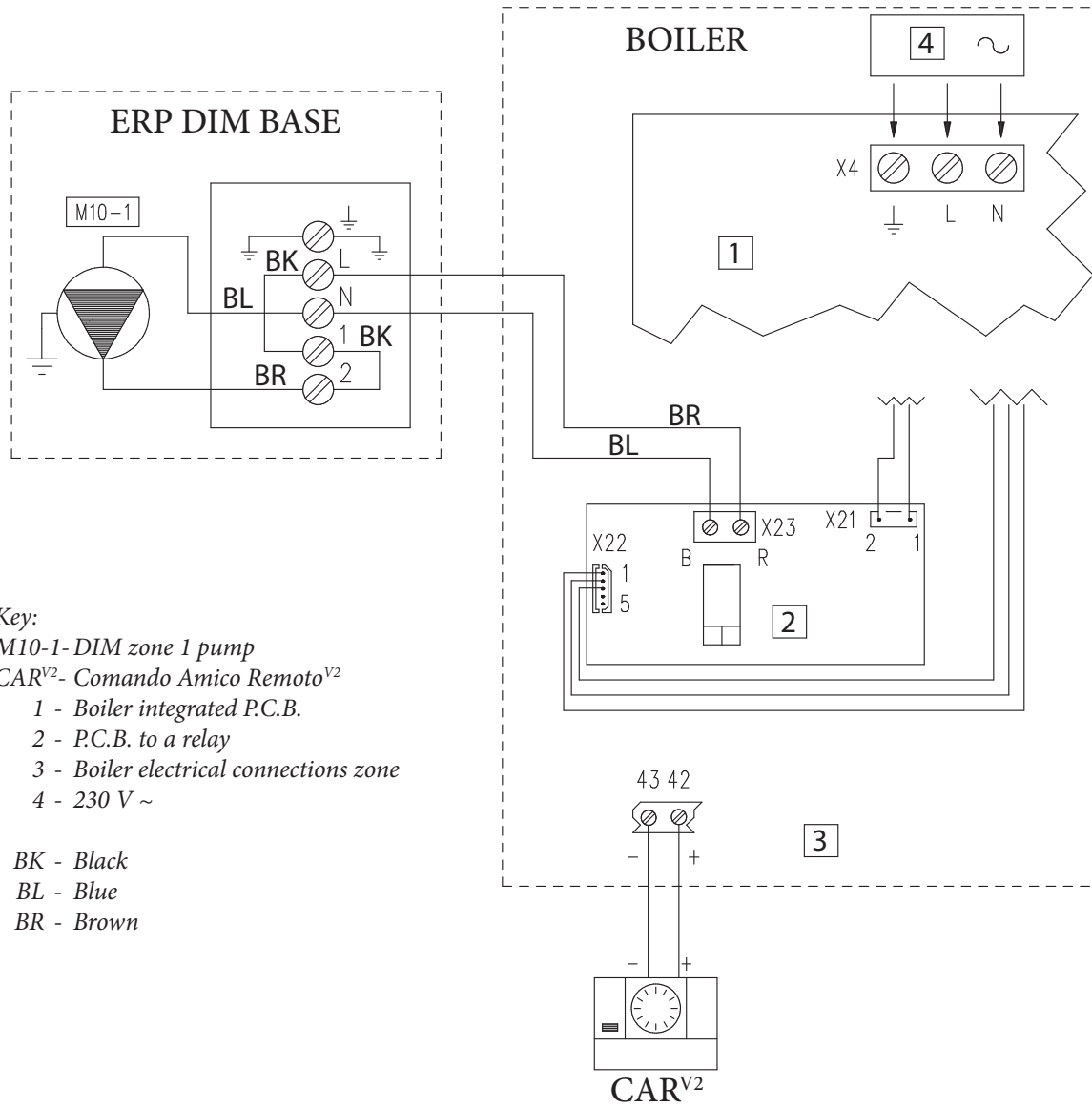

- Key:
- M10-1- DIM zone 1 pump
 - CAR^{V2}- Comando Amico Remoto^{V2}
 - 1 - Boiler integrated P.C.B.
 - 2 - P.C.B. to a relay
 - 3 - Boiler electrical connections zone
 - 4 - 230 V ~
- BK - Black
 BL - Blue
 BR - Brown

Only use for boilers equipped with the Comando Amico Remoto^{V2} remote control and the internal 1 relay board. In this case the electrical connection of the CAR^{V2} must be made directly to the boiler as described in the relative instruction book.



3.3 WIRING DIAGRAM - BOILER CONNECTION USING EXTERNAL RELAY.

10

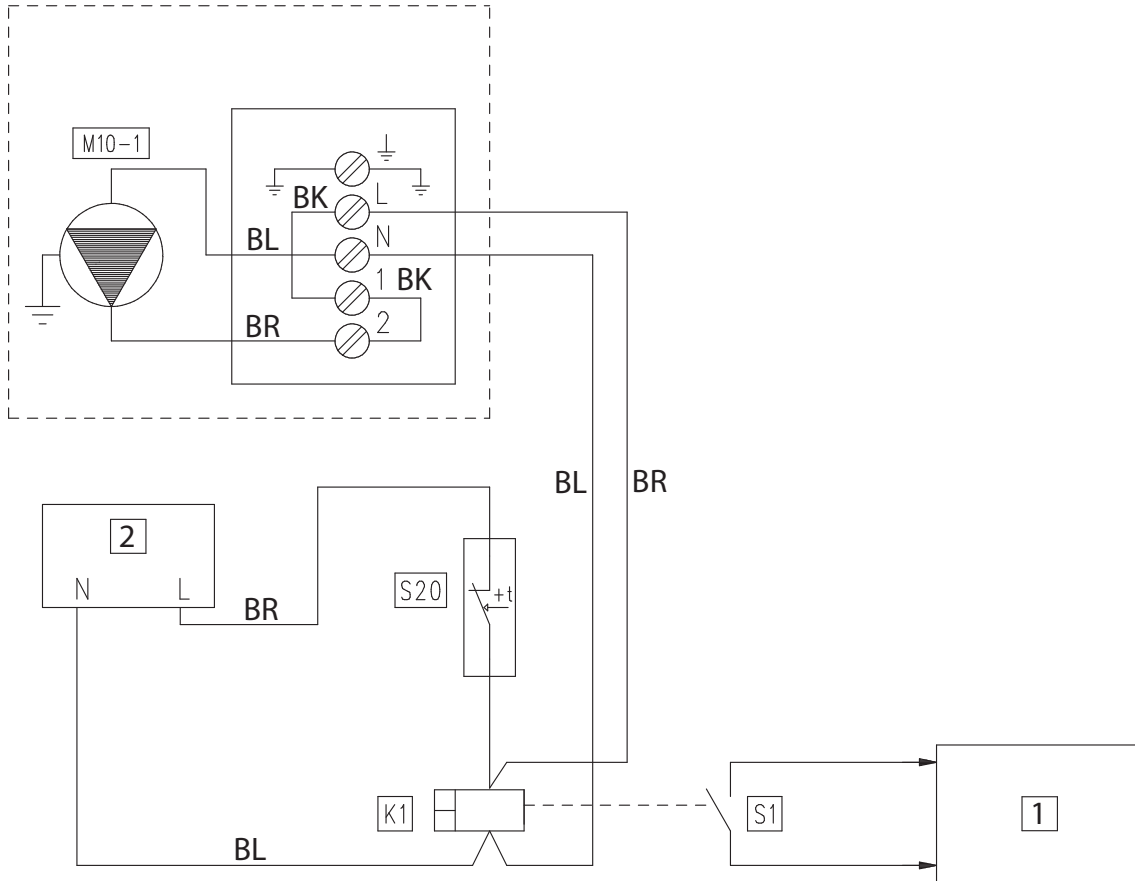

Key:

- M10-1 - DIM zone 1 pump
- K1 - External relay (optional)
- S1 - External relay contact (optional)
- S20 - Room thermostat (optional)
- 1 - Boiler ignition request
- 2 - 230 V ~

- BK - Black
- BL - Blue
- BR - Brown

If a remote control or zone control room thermostat is used, its electric connection must be made directly to the boiler, as described in the relative instruction book.

INSTALLER

USER

MAINTENANCE TECHNICIAN

TECHNICAL DATA



3.4 WIRING DIAGRAM - CONNECTION TO MULTI-ZONE P.C.B. KIT.

11

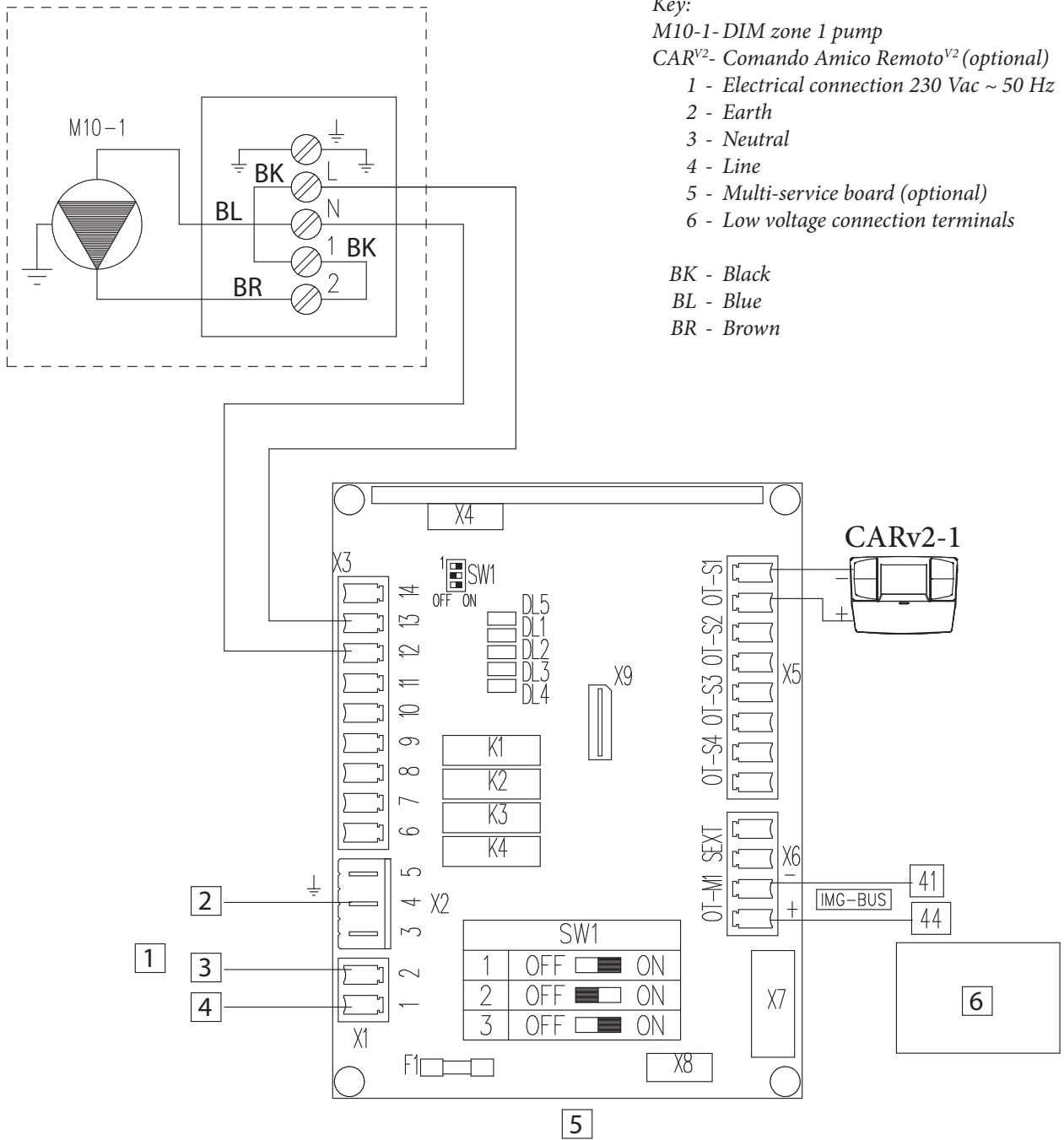

3.5 WIRING DIAGRAM CONNECTION TO VICTRIX MAIOR, EXTRA, INTEC V2 SERIES BOILER VIA MULTIFUNCTION RELAY.

12

Key:

M10-1 - DIM zone 1 pump

1 - 230 V Connection terminal board

2 - 230 Vac - 50 Hz

BK - Black

BL - Blue

BR - Brown

G/V - Yellow/green

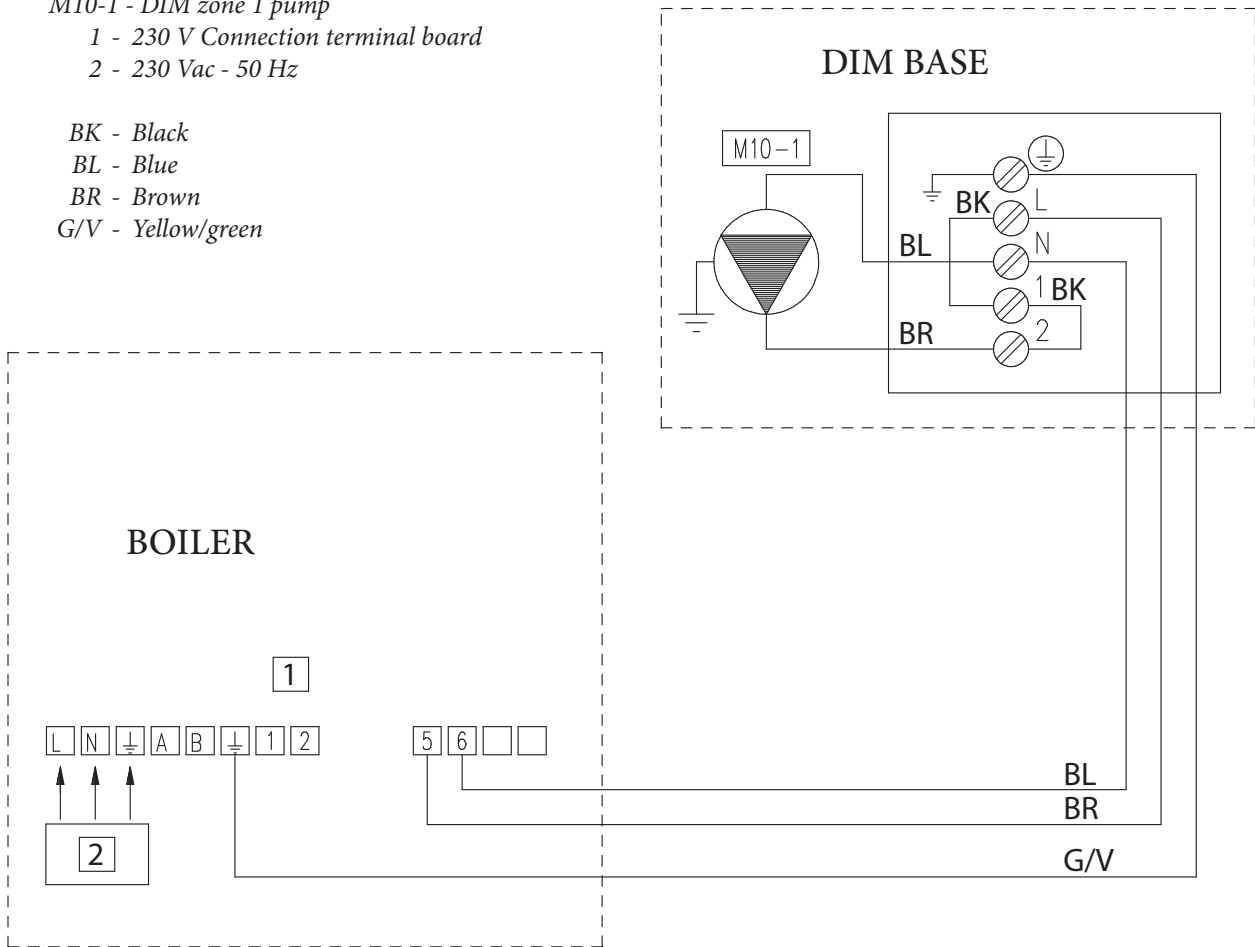

Configuration required on boiler board: Multifunction relay (K70), with P.4 = 6 (central heating mode active).

3.6 TROUBLESHOOTING.

- Presence of air in the system. Check the opening of the boiler vents, of the the central heating system and of the DIM. Make sure the system pressure and expansion vessel factory-set pressure values are within the set limits; the factory-set value for the expansion vessel must be 1.0 bar, and system pressure between 1 and 1.2 bar.

INSTALLER

USER

MAINTENANCE TECHNICIAN

TECHNICAL DATA



4 TECHNICAL DATA

INSTALLER

USER

MAINTENANCE TECHNICIAN

TECHNICAL DATA

		ErP DIM Base
Maximum nominal pressure	bar	3
Maximum operating pressure	°C	90
Water content in device	l	0.9
Total head available in direct zone with 1000 l/h flow rate (max)	kPa (m c.a.)	42.90 (4.37)
Empty device weight	kg	12.5
Full device weight	kg	13.9
Electrical connection	V/Hz	230/50
Maximum input	A	0.60
Installed electric power	W	60
Power in Stand-by	W	0
Value EEI	-	≤ 0.20 - Part. 3
Electric plant protection	-	IPX5D
Maximum distance between boiler - DIM	m	15





Immergas S.p.A.

42041 Brescello (RE) - Italy

Tel. 0522.689011

immergas.com



This instruction booklet is
made of ecological paper.

