

# RAPAX 200 V3 RAPAX 200 SOL V3 RAPAX 300 V3 RAPAX 300 SOL V3

Heat pump water heaters

**IE**

**Instructions and warnings**

\*1.043869ENG\*

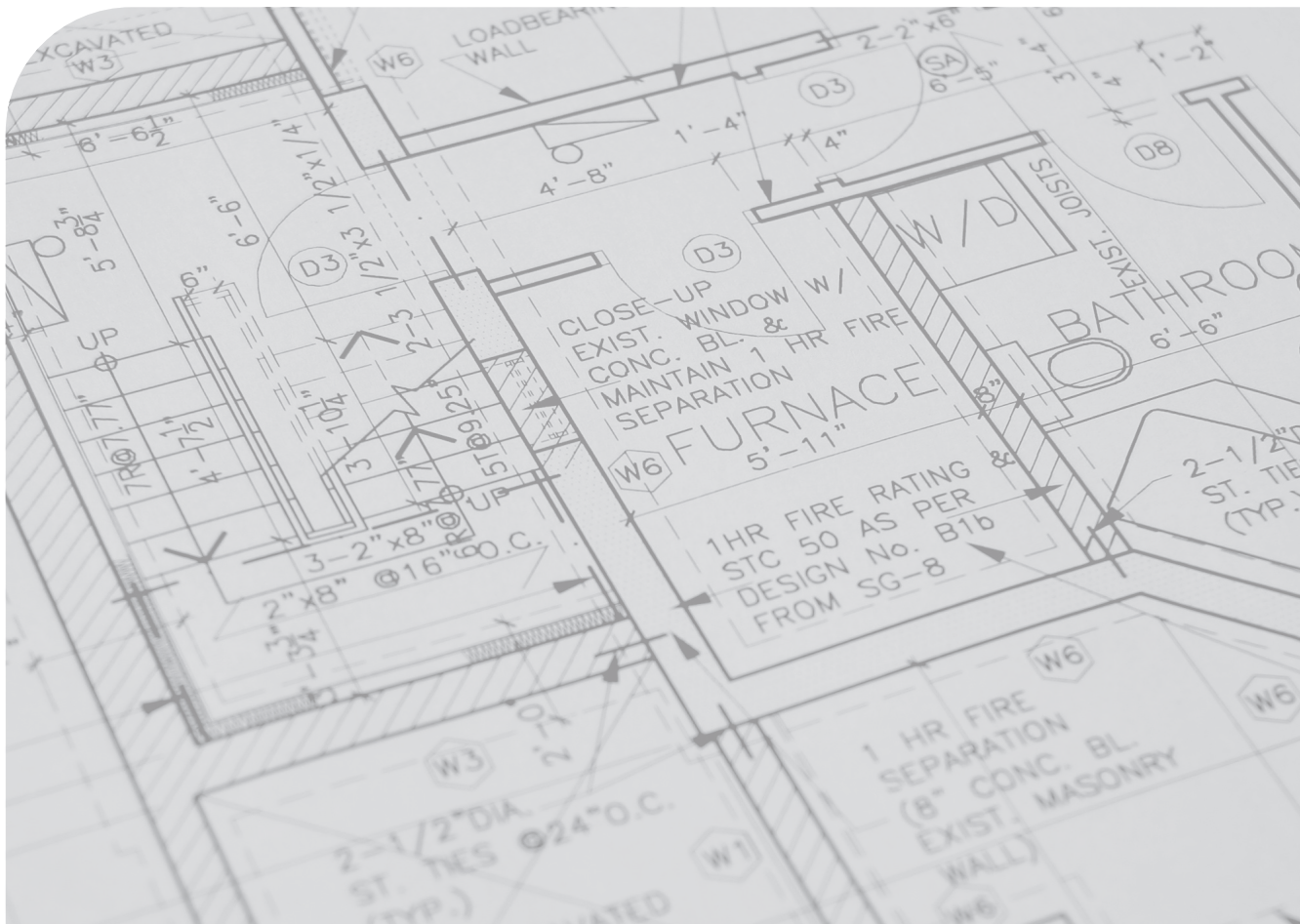

# WATER HEATER WIRING DIAGRAM

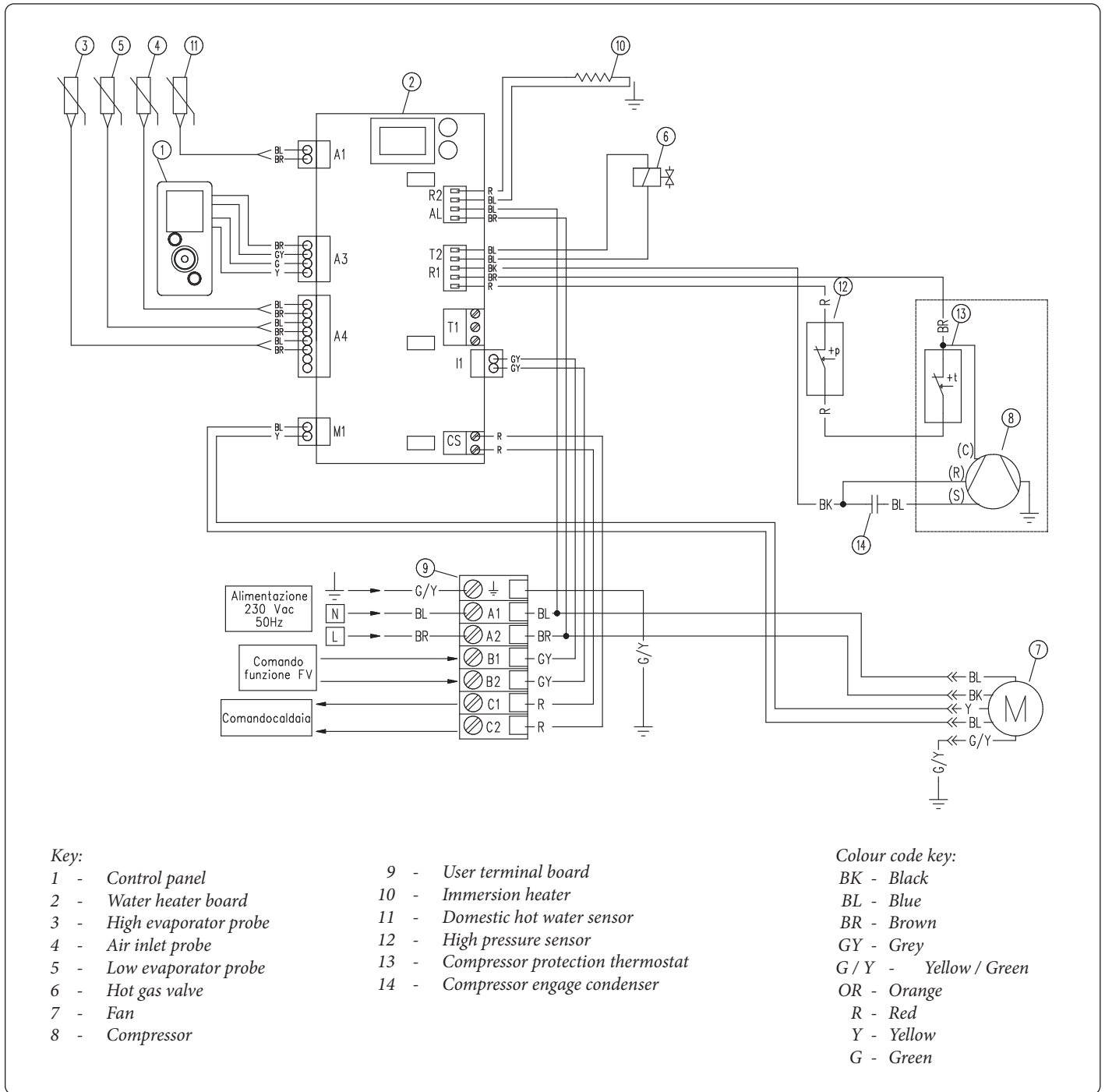

# IMPORTANT RECOMMENDATIONS

## WARNINGS.

This device may only be used by adult users whose physical, sensory or mental abilities are not impaired.

This instruction manual (User section) and/or the operating instructions should be read by skilled technical staff before using this appliance.

Children must be supervised to ensure they do not play with the appliance.

This appliance can be used by children under the age of 8 and by persons with reduced physical, sensory or mental capabilities, or lack of experience or required knowledge under the supervision of a person responsible for their safety or who is aware of the safe use instructions and of the risks they run. Children must not play with the appliance.

Cleaning and maintenance by the user must not be carried out by unsupervised children.

This appliance has been designed to serve one residential housing unit only (and similar) subject to assessment of the energy requirement for domestic hot water; it is not a heating system pursuant to the legislation in force.

## INSTALLATION.

**Warning:** due to its weight (from 80 to 111 kg depending on the version), this appliance must be handled with care to avoid injury to persons or damage to property and to the product itself. Installation must therefore be performed taking into account the following instructions:

- install the appliance in a frost-free room. The warranty does not cover any appliance breakdown caused by excessive pressure due to the safety valve blocking because of ice. If the appliance is damaged due to the safety valve being tampered with, the product is no longer covered by the warranty.
- Ensure the floor on which the appliance is to be installed is suitable to withstand the appliance's own weight and that of the water content (approximately from 197 to 270 litres, according to the version). It is recommended to perform a structural assessment by the designer of the dwelling.
- If the storage tank is mounted on a false ceiling,

under the roof or above a living area, it is mandatory to install a drip tray to be connected to the drain.

- Suitably aerate the installation room in the event the appliance is to be installed in a room and/or in a position where the ambient temperature is always higher than 35°C.
- The heat pump water heaters cannot be installed in zones 0, 1 and 2.

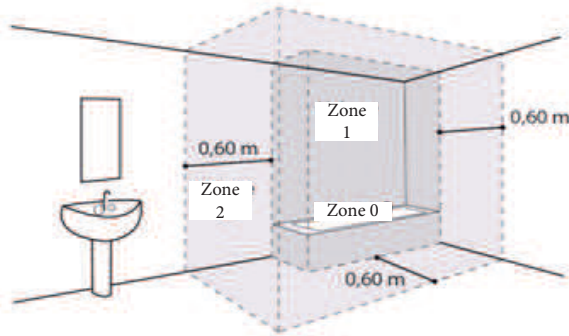

- This device is intended for use up to a maximum height of 2000 m.
- Position the appliance in an accessible area and at such a distance from the wall to permit correct maintenance / accessibility / removal and any replacement (Parag. 2.1).
- Refer to the installation diagrams (Parag. 2.1).
- Do not install near sources of heat.

This water heater is fitted with a thermostat with an operating temperature over 60°C in the maximum position, which can limit the proliferation of legionella bacteria inside the tank.

**Warning:** water can immediately cause serious burns when over 50°C. Always check the water temperature before bathing or showering.

**Warning:** failure to comply with recommended installation procedures, especially those related to the room volume below the minimum of 20 m<sup>3</sup>, may significantly reduce system performance.



- It is recommended to provide suitable shut-off valves on the hydraulic connection to allow for any routine and extraordinary maintenance operations which might require emptying/filling the water heater.
- In order to prevent any stability and safety issues, it is obligatory to secure the boiler to the floor, on a flat surface, using the fastening anchors supplied.

#### HYDRAULIC CONNECTION.

It is mandatory to install a safety device, set to be triggered at 0.7 MPa (7 bar) (not supplied with the water heater), sized 3/4", compliant with standard EN1487 as amended and added, and in any case compliant with local regulations in force: this safety device is to be fitted to the cold water inlet of the water heater and must be protected against freezing.

The safety valve must be protected from ice

The safety unit must be fitted with a discharge device (overpressure) to be operated regularly to remove any limestone deposits.

The safety valve must also be checked regularly to ensure it is not blocked.

The pressure reducer (not supplied as standard) is required when the water mains pressure exceeds 0.5 MPa (5 bars) and must be mounted on the main water supply line.

The safety unit must also be connected to an open drain pipe, in a frost-free environment, with a permanent downward gradient, to remove any expansion water from the heating process, or drainage water from the water heater.

The maximum operating pressure of the heat exchanger circuit must not exceed 0.3 MPa (3 bars) and its max temperature must not exceed 85°C.

To perform any discharge operations of the water heater, strictly adhere to the following sequence:

- disconnect the appliance from the electrical power supply.
- Disconnect the appliance from the mains water supply (cold water).
- Open the hot water tap.
- Actuate the discharge device of the safety unit.

**N.B.:** Installing the appliance entails installing an adequately sized DHW expansion vessel and safety valve on the water supply.

#### WIRING.

Before removing the cover of the water heater, always ensure the power is disconnected, to prevent any risk of injury due to electric shocks.

The following must be provided upstream of the electrical system:

- a circuit breaker or 16A multi-pole fuse with contacts compliant with regulations in force.
- A 30 mA differential circuit breaker.

Should the power cable be found to be damaged for any reason, it must be replaced by the After-sales Support, and/or in any case by skilled and qualified staff.

The water heater must be connected to earth according to the methods set out by the regulations in force.

A special terminal, suitably marked  is provided for the specific purpose.

This manual is supplied jointly with the water heater; in the event of loss it may also be obtained from the Authorised area Support service or be downloaded from the suitable website.



## **General warnings**

*All Immergas products are protected with suitable transport packaging.*

*The material must be stored in a dry place protected from the weather.*

*The instruction booklet is an integral and essential part of the product and must be given to the new user in the case of transfer or succession of ownership.*

*It must be stored with care and consulted carefully, as all of the warnings provide important safety indications for installation, use and maintenance stages.*

*This instructions manual provides technical information for installing Immergas water heaters. As for the other issues related to water heater installation (e.g. safety in the work site, environment protection, injury prevention), it is necessary to comply with the provisions of the regulations in force and the principles of good practice.*

*In compliance with legislation in force, the systems must be designed by qualified professionals, within the dimensional limits established by the Law. Installation and maintenance must be performed in compliance with the regulations in force, according to the manufacturer's instructions and by professionally qualified staff, intended as staff with specific technical skills in the system sector, as envisioned by the Law.*

*Improper installation or assembly of the Immergas appliance and/or components, accessories, kits and devices can cause unexpected problems for people, animals and objects. Read the instructions provided with the product carefully to ensure proper installation.*

*Maintenance must be carried out by skilled technical staff. The Authorised After-Sales Service represents a guarantee in terms of qualifications and professionalism.*

*The appliance must only be destined for the use for which it has been expressly declared. Any other use will be considered improper and therefore potentially dangerous.*

*If errors occur during installation, operation and maintenance, due to non-compliance with technical laws in force, standards or instructions contained in this book (or however supplied by the manufacturer), the manufacturer is excluded from any contractual and extra-contractual liability for any damage and the appliance warranty is invalidated.*





## Dear Customer,

Congratulations for having chosen a top-quality Immergas product, able to assure well-being and safety for a long period of time. As an Immergas Customer, you can also count on a qualified after-sales service, prepared and updated to guarantee constant efficiency of your water heater. Read the following pages carefully: you will be able to draw useful tips on the proper use of the device, compliance with which will confirm your satisfaction with the Immergas product.

For assistance and routine maintenance, contact Authorised Service Centres: they have original spare parts and are specifically trained directly by the manufacturer.

## INDEX

Water heater wiring diagram .....	2
Important recommendations.....	3
Warnings.....	3
installation.....	3
Hydraulic connection. ....	4
Wiring.....	4
1 Introducing the product.....	8
1.1 Important advice. ....	8
1.2 Technical features.....	9
1.3 Dimensions and components.....	10
2 Installation .....	12
2.1 Choosing the place of installation.....	12
2.2 Product installation.....	17
2.3 Hydraulic connection.....	17
2.4 Air intake connection.....	18
2.5 Electrical connection.....	18
2.6 Electrical connection for plus boiler and photovoltaic system.....	21
2.7 Commissioning .....	22
2.8 Thermal solar connection diagram (optional).....	24
2.9 Boiler connection diagram (optional).....	24
3 Parameter settings / Use.....	25
3.1 remote panel .....	25
3.2 Description of the symbols.....	25
3.3 Main menu .....	25
3.4 System settings.....	26
3.5 Parameters to be adjusted upon installation.....	26
3.6 Selecting the operating mode.....	27
3.7 Locking the controls.....	27
3.8 Mode in “Heat pump prioritised” system.....	27
3.9 Mode in “Connected to boiler” system.....	27
3.10 Mode in “Connected to solar sys.” system .....	28
4 Recommendations - maintenance and repairs.....	29
4.1 Advice for the user.....	29
4.2 Household maintenance.....	29
4.3 Maintenance by approved professionals.....	29
4.4 Troubleshooting support.....	30
4.5 Work on the water heater.....	32
4.6 Quick fault diagnosis for use carried out by a professional technician.....	33
4.7 After-sales service.....	34
4.8 Scope of application of the warranty.....	34
4.9 Declaration of conformity.....	34
5 Product fiche (in compliance with Regulation 812/2013).....	35
6 Parameters for filling in the package fiche.....	37

Il fabbricante declina ogni responsabilità dovuta ad errori di stampa o di trascrizione, riservandosi il diritto di apportare ai propri prospetti tecnici e commerciali qualsiasi modifica senza preavviso.



# 1 INTRODUCING THE PRODUCT

## 1.1 IMPORTANT ADVICE.

**Transport and storage.** The product may be transported in upright position on a pallet, or rotated by 90° on a side.

The appropriate side is shown clearly on an information label placed on the product packing box.

It is forbidden to transport the product lying on its other sides as it could irreparably damage it.

We recommend you strictly follow these instructions.

The product warranty is rendered null and void if the above instructions are not complied with.

**The manufacturer declines** any liability for any faults to the product resulting from transport or handling not complying with the above recommendations.

Under no circumstances may this product be stacked (Fig. 1).

**Safety directives.** The installation work and commissioning of thermodynamic water heaters can be hazardous due to high pressure and live electrical parts.

Thermodynamic water heaters must be installed, commissioned and serviced by trained and qualified staff only.

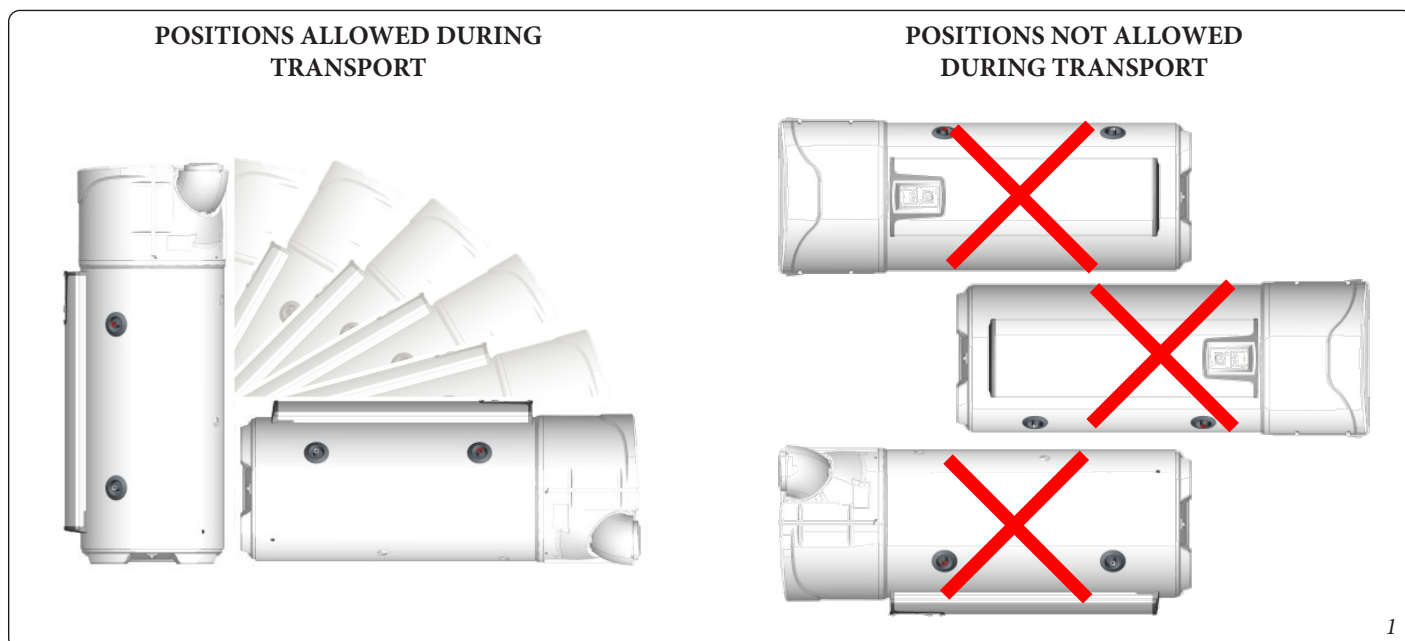



## 1.2 TECHNICAL FEATURES.

Technical characteristics	Unit of measurement	Rapax 200 V3	Rapax 200 SOL V3	Rapax 300 V3	Rapax 300 SOL V3
Dimensions	mm	H 1617 x L 620 x P 665		H 1957 x L 620 x P 665	
Empty weight (version without coil)	kg	80	-	92	-
Empty weight (version with coil)	kg	-	97	-	111
Tank capacity	L	200	197	270	263
Hot + cold water fitting	-	3/4" M			
Anti-corrosion protection	-	Magnesium anode			
Maximum operating pressure	bar	8			
Electrical connection (voltage/frequency)	V	230 V single-phase 50 Hz			
Max total power absorbed by the device	W	2300			
Max power absorbed by heat pump	W	700			
Power absorbed by auxiliary electrical unit	W	1600			
COP (at 15°C)		3.05	3.07	3.61	3.44
Setting range of the water temperature of the heat pump	°C	from 50 to 62 (temperature factory setting 52°C)			
Temperature range for using the heat pump (air temperature)	°C	from -5 to +43			
Coating diameter	mm	160			
Acoustic output	db (A)	53			
Air flow rate without ducts - Speed 1	m <sup>3</sup> /h	310			
Air flow rate without ducts - Speed 2	m <sup>3</sup> /h	390			
Load losses acceptable on ventilation circuit, without affecting performance	Pa	25			
Coolant	-	R513A			
Mass of coolant fluid	kg/l	0.80		0.86	
Coolant volume	Ton CO <sub>2</sub> Eq.	0.50		0.54	



### 1.3 DIMENSIONS AND COMPONENTS.

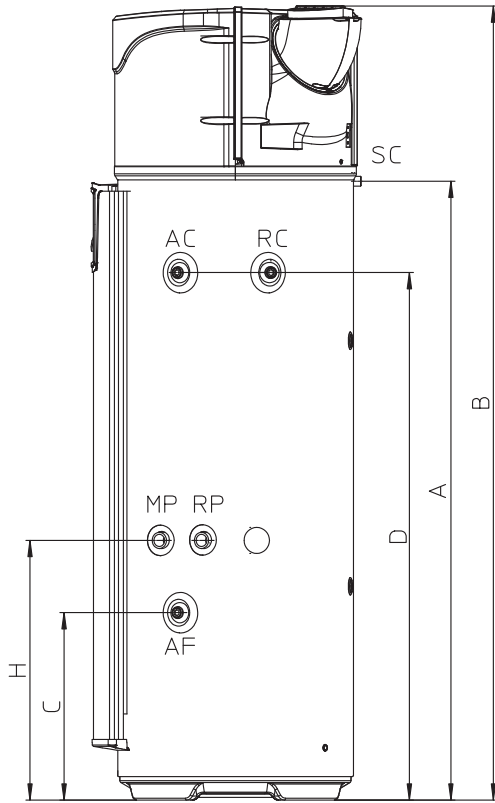

**Key:**

- AC - Domestic hot water outlet 3/4" M
- AF - Domestic cold water inlet 3/4" M
- MP - 1" F Flow from solar panels (Rapax Sol V3 model only)
- RP - 1" F Return to solar panels (Rapax Sol V3 model only)
- SC - Condensate drain  $\phi$  20
- RC - 3/4" M Recirculation (Rapax Sol V3 model only)

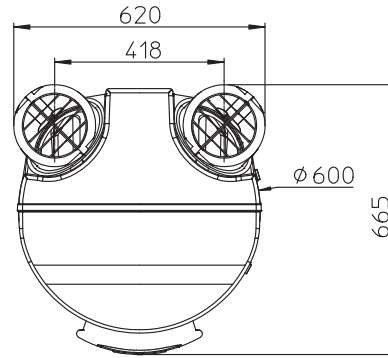

Ref	Description	Rapax 200 V3	Rapax 200 Sol V3	Rapax 300 V3	Rapax 300 Sol V3
A	Condensate Outlet	1166 mm		1525 mm	
B	Total Height	1617 mm		1957 mm	
C	Cold water inlet	304 mm	462 mm	304 mm	462 mm
D	Hot water outlet	961 mm		1300 mm	
H	Heat exchanger inlet	-	640 mm	-	640 mm



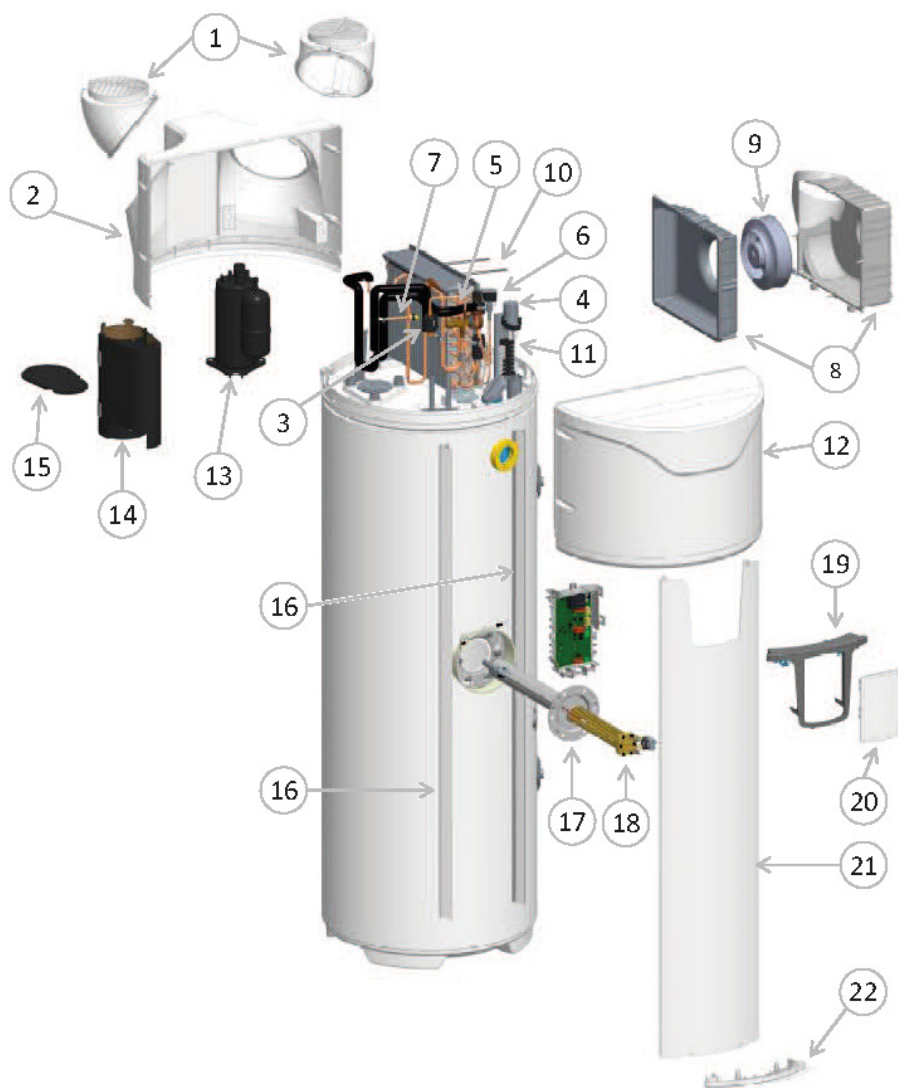

*Key:*

- |                       |                           |
|-----------------------|---------------------------|
| 1 - Adjustable nozzle | 11 - Terminal board unit  |
| 2 - Rear panel        | 12 - Front cover          |
| 3 - Dryer filter      | 13 - Compressor           |
| 4 - Condenser 15 F    | 14 - Compressor coating   |
| 5 - Pressure reducer  | 15 - Compressor cover     |
| 6 - Gas By-Pass Valve | 16 - Column support guide |
| 7 - Pressure switch   | 17 - Protection cover     |
| 8 - Spiral unit       | 18 - Heating element      |
| 9 - Fan               | 19 - Control mount        |
| 10 - Spiral elastic   | 20 - Control unit         |
|                       | 21 - Front column         |
|                       | 22 - Low part cover       |

**Not shown:** manual, dielectric connection, condensate draining pipe, safety unit.



# 2 INSTALLATION

## 2.1 CHOOSING THE PLACE OF INSTALLATION.

<b>Floor strength</b>	<ul style="list-style-type: none"> <li>• Withstands a load of 400 kg at least (surface below boiler)</li> </ul> <p><b>Note:</b> only install a water storage tank under the water heater when this is positioned above in residential buildings.</p>	
<b>The installation area shall be suitable for protection index IPX1B.</b>		
	<b>Non-ducted or semi-ducted configuration</b>	<b>Ducted configuration</b>
<b>Type of installation room</b>  <b>Room examples</b>  <b>Volume of room where air is extracted</b> <b>Temperature of water heater installation room</b> <b>Air inlet temperature</b>  <b>Ceiling height</b> <b>Surface area required</b>	<ul style="list-style-type: none"> <li>• Unheated room, characterised by temperature exceeding 5°C and preferably insulated from the home's heated rooms.</li> <li>• Recommended room = underground or basement, room where the temperature is higher than 10°C all year round.</li> <li>• garage, boiler room (with the exception of rooms where type B generators are installed), basement floor, ironing room, etc.</li> <li>• Volume &gt; 20 m<sup>3</sup></li> <li>• from 5°C to 43°C.</li> <li>• -5°C to 43°C.</li> <li>• &gt; 2.10 m.</li> <li>• 2.10 m<sup>2</sup> (Fig. 4).</li> <li>• Crucial for the surface to be level.</li> </ul>	<ul style="list-style-type: none"> <li>• <b>Room at least frost-free.</b></li> <li>• Recommended room = living space (the heat loss from the water heater is not wasted), close to the outer walls.</li> <li>• Do not install close to sleeping areas because of the noise produced.</li> <li>• laundry room, cellar, cupboard in entrance hall, etc.</li> <li>• /</li> <li>• &gt; 1°C.</li> <li>• -5°C to 43°C.</li> <li>• &gt; 2.10 m.</li> <li>• 2.10 m<sup>2</sup> (Fig. 4).</li> <li>• Crucial for the surface to be level.</li> </ul>



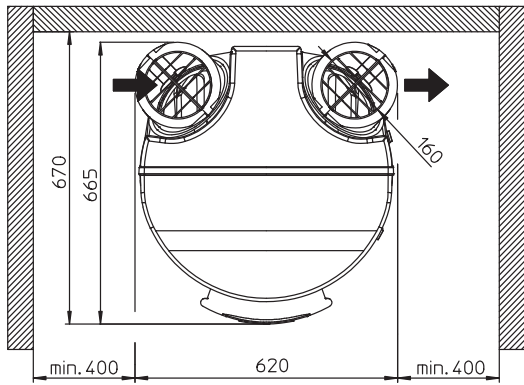

"Non ducted" configuration

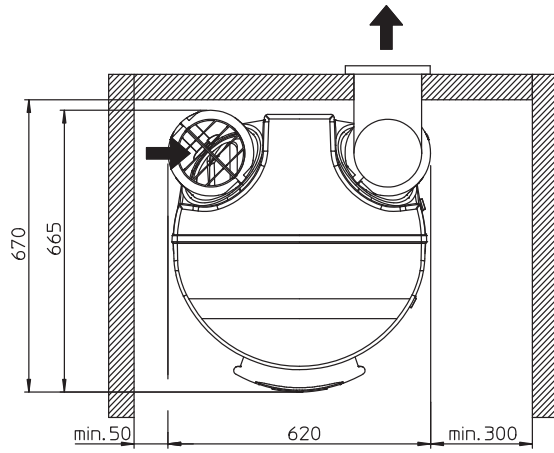

"Ducted" configuration

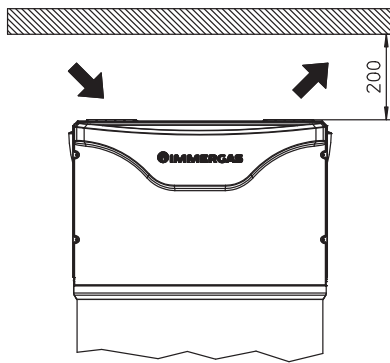

"Non ducted" configuration

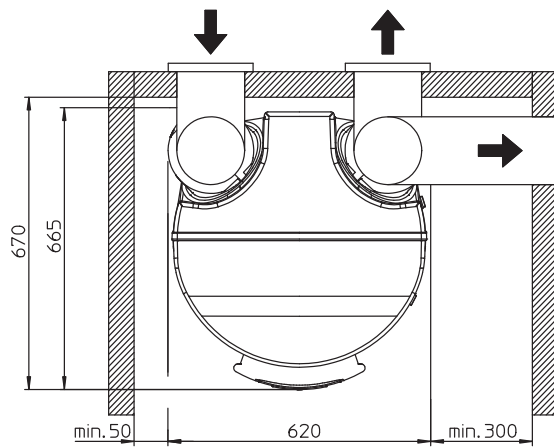

"Ducted" configuration



**RECOMMENDED CONFIGURATIONS.**

• **1<sup>st</sup> configuration: installation without duct in unheated room**

(Volume > 20 m<sup>3</sup>) (Fig. 5).

**INNER/INNER Parameter**

(Par. 3.5).

Examples of unheated rooms:

- Garage: Recovery of free calories released by household electrical appliances operating.
- Laundry room: dehumidifying the room and recovery of waste calories from washing machines and tumble-dryers.
- Room in basement: recovery of free calories released by the

floor and walls of the basement.

• **2<sup>nd</sup> configuration: installation in a heated or unheated room, with ducts** (Fig. 6).

**OUTER/OUTER Parameter**

(Par. 3.5).

Recommendations:

- Comply with maximum duct lengths (Par. 2.4).
- Use rigid or semi-rigid ducts.
- Provide grilles at air intake and outlet to avoid ingress of foreign bodies. Note: manually shuttered air inlet and outlet grids are forbidden.

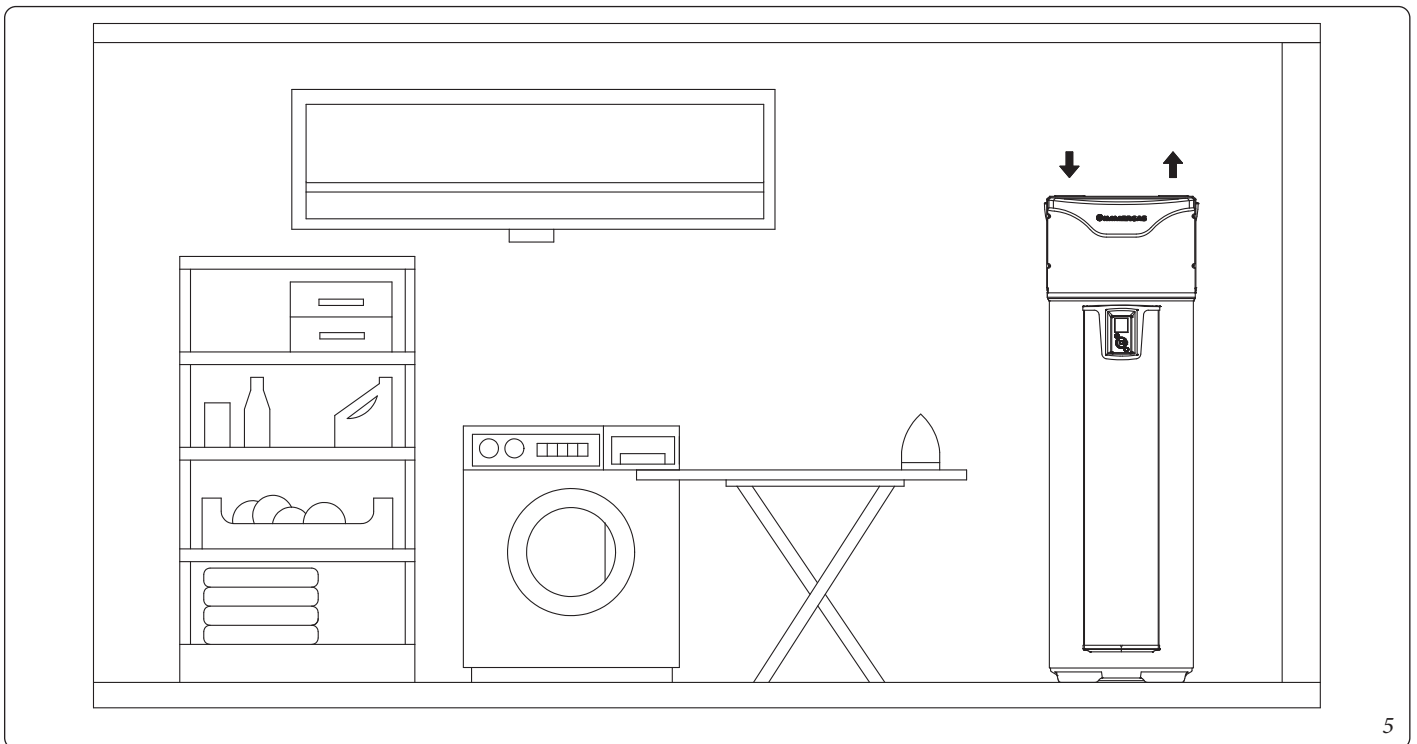

5

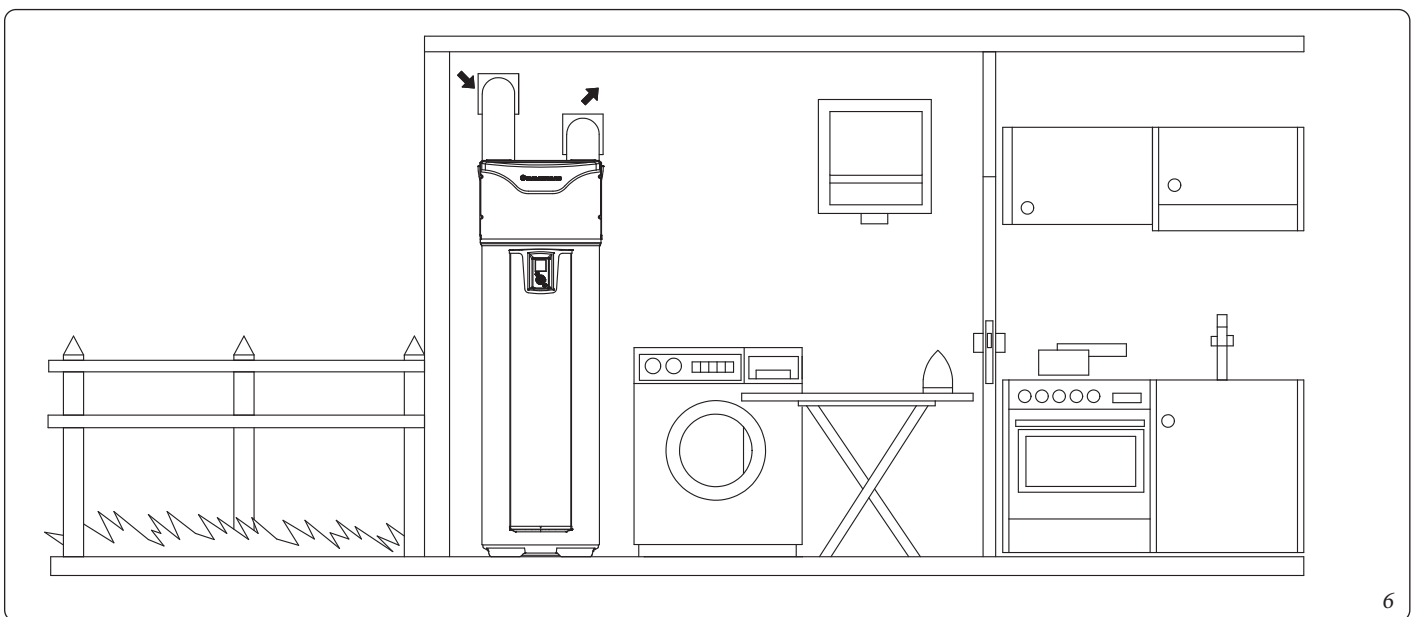

6



**CONFIGURATIONS IN CERTAIN CONDITIONS (subject to assessment).**

- **Installation in unheated room, with 1 duct only (volume > 20 m<sup>3</sup>) (Fig. 7).**

**INNER/OUTER Parameter (Par. 3.5).**

Possible consequence:

- In the event of installation with air intake in the same room and expulsion through a duct, the ventilation openings must be sized with a minimum diameter of 160 mm.

**N.B.:** in winter, the intake air will be colder than that discharged by the water heater, which will increase garage cooling.

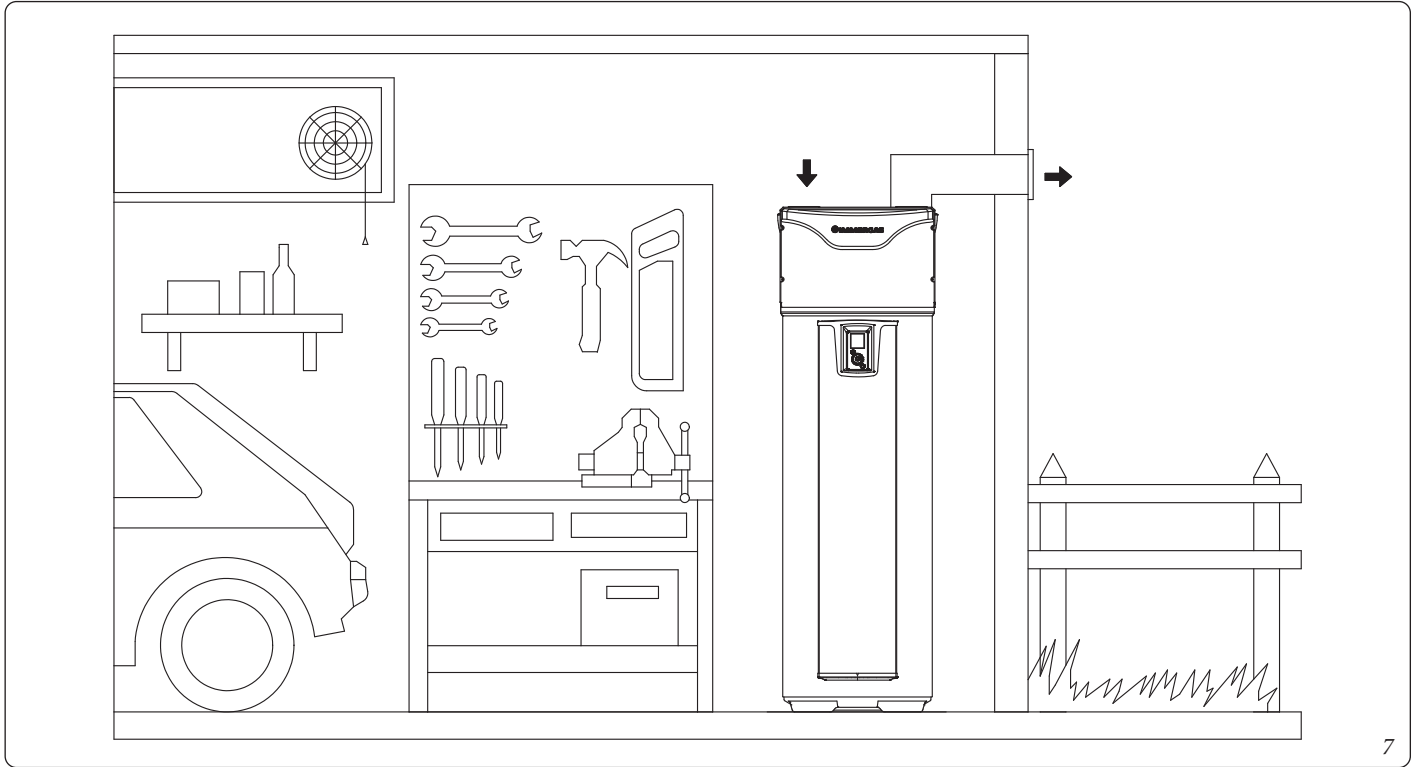

## FORBIDDEN CONFIGURATIONS..

Installation configurations forbidden	Associated risks
✘ The water heater takes air from a room containing a paid heat source used for heating this room.	Excessive system consumption: the water heater no longer uses free calories, but uses those produced by other devices connected to other energy sources.
✘ Connection to a residential ventilation system.	The air flow rates in the thermodynamic water heater are incompatible with those of a residential ventilation system. Furthermore, the residential ventilation system ducts may convey greasy vapour and dust, potentially harmful for the duration in service of your water heater.
✘ Connection to an attic.	In the presence of inadequate insulation between the building and the relative attics, this type of installation may increase the thermal loss of the building. In extreme cases, condensate might form on the ceilings of the rooms under the attic due to its cooling. There is a greater risk from falling objects and dust ingress to the water heater in this configuration, which could reduce its life expectancy.
✘ duct which draws air from the outside, conveying cold air inside.	Significant loss of the coefficient of performance (COP) and much greater cooling of the room.
✘ Connection to a geo-thermal system.	Excessive loss of load, and problems balancing the two fans in series. High risk of clogging the evaporator.

### Other prohibitions:

- Do not connect the device's fan to a tumble-dryer.
- Avoid very dusty rooms.
- Do not extract air containing solvents or explosive materials.
- Do not connect the appliance to a suction hood used to extract greasy or polluted air.
- Do not install the water heater in a room exposed to frost.
- Do not place any objects on the water heater.
- In non-ducted or semi-ducted configuration, do not place it in a room where an open chamber heat generator is installed (type B).





## 2.2 PRODUCT INSTALLATION.

- 1- Take the water heater to the place of installation.
- 2- Open the packaging.
- 3- Separate the water heater from the pallet and place it next to the hydraulic connection.

**The water heater must be installed on a smooth and level surface ( $\pm 1^\circ$ ).**

If the surface is not level, the position must be adjusted using the levelling feet.

Unless this is done, there could be problems with removal of condensates, leading to icing up.

It is a mandatory requirement (in accordance with article 20 of EN 60335-1) for the boiler to be secured to the floor using the fixing attachments provided (Fig. 8).

- 4- Adjustment of air intake and outlet vents.
  - Remove the screws from behind each of the adjustable outlets, with a screwdriver (Fig. 9).
  - After removing the clamping screws, the outlets may be rotated (through  $360^\circ$ ) to help install the product (Fig. 10).
  - To aid correct positioning of the ducts on the adjustable outlets, a specific position is required (Fig. 11) to extract the outlets from their housing.

**N.B.:** the configuration shown in Fig. 13 is forbidden: the device draws in the exhaust air, which is colder.

This phenomenon, called recirculation, significantly reduces the performance of the appliance.

## 2.3 HYDRAULIC CONNECTION.

### Connection to the cold water inlet.

Before connecting the water system, it is essential to clean the pipes thoroughly, to avert the risk of any metal or other particles entering the boiler tank.

It is mandatory to install a safety device, set to be triggered at 0.7 MPa (7 bars) (not supplied with the water heater), sized  $3/4''$ , compliant with standard EN1487 as amended and added, and in any case compliant with local regulations in force: this safety device is to be fitted to the cold water inlet of the water heater and must be protected against freezing.

**Note:** no hydraulic fittings (stop valve, pressure reducer, etc.) must be placed between the safety unit and the cold water inlet of the water heater, except for a copper pipe.

Connect the safety device to a drain pipe kept in the open air, in a frost-free environment, with a permanent downward gradient, to remove any expansion water generated by the heating process or drainage water coming from the water heater itself.

The pipes used must withstand a temperature of  $85^\circ\text{C}$  and a pressure of 1 MPa (10 bar).

When the inlet water pressure exceeds 0.5 MPa (5 bar), a pressure reducer is required (not supplied as standard).

**The pressure reducer must be installed at the beginning of the main distribution network.**

A pressure of 0.3 to 0.4 MPa (3 and 4 bar) is recommended.

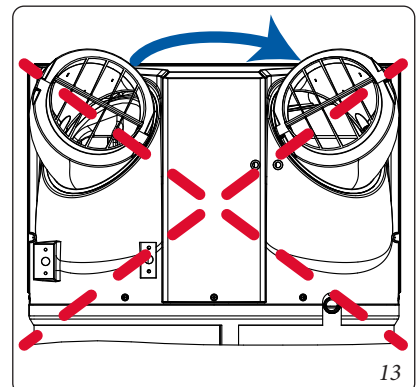
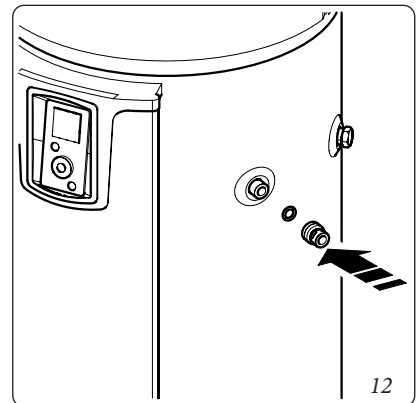
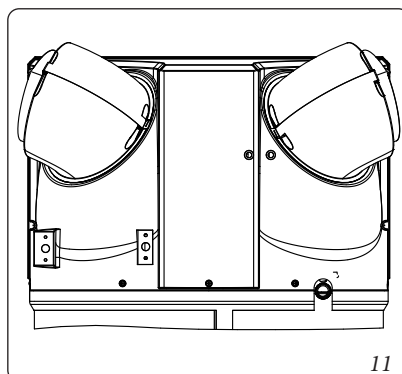
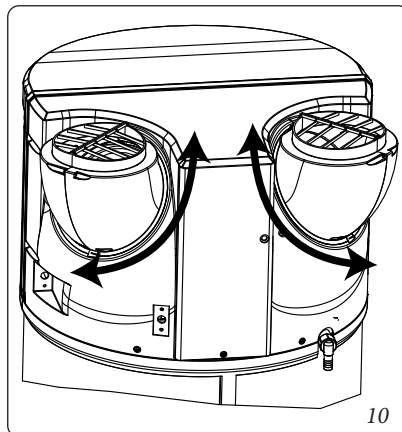
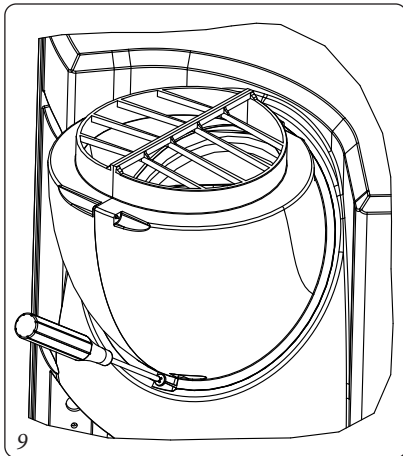
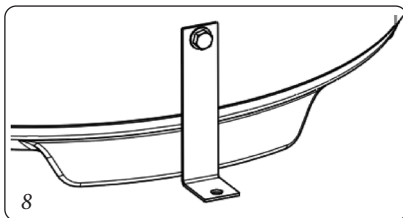

### Connection to the hot water inlet.

**Note:** do not connect the hot water directly to copper pipes, in order to avoid copper/iron galvanic coupling (risk of corrosion). It is therefore obligatory to fit a dielectric fitting on the hot water outlet (supplied with the appliance) (Fig. 12).

**Any corrosion on the threads of the hot water outlet fitting, due to failure to use the fitting supplied, shall void product warranty.**

In the event pipes in synthetic material have been used (e.g.: PER, multilayer...), we strongly recommend installing a thermostatic control device at the exit side of the water heater and set it according to the performance of the material used.

### PLUMBING CONNECTIONS FOR COIL VERSION.

Especially for Rapax 300 V3 the use of recirculation is not recommended; this type of installation may cause water destratification in the tank, leading to increased use of the heat pump and electrical resistor.

### Connection to the recirculation fitting.

**N.B.:** do not connect the recirculation fitting directly to copper pipes, in order to avoid copper/iron galvanic coupling (risk of corrosion). It is therefore mandatory to mount a dielectric system to the recirculation fitting (not supplied as standard with the device).

**Any corrosion on the threads of the recirculation fitting, due to failure to use the above fitting, shall void product warranty.**

**N.B.:** if recirculation is not used, close the fitting with the “cap + gasket” set (supplied with the appliance).

### Connection of the primary circuit of the boiler.

**N.B.:** protect from overpressure caused by water expansion during heating with a 0.3 MPa (3 bars) valve, and with a closed diaphragm expansion vessel (if not fitted in the boiler). The operating pressure of the circuit must not exceed 0.3 MPa (3 bars), and its temperature must not be higher than 85°C.

### Solar circuit connection.

**N.B.:** protect from overpressure caused by water expansion during heating with a 0.6 MPa (6 bars) valve, and with a closed diaphragm expansion vessel. The operating pressure of the circuit must not exceed 0.6 MPa (6 bars), and its temperature must not be higher than 100°C. A glycol mixture must be provided as heat transfer fluid for frost and corrosion protection.

### Removing the condensate.

**N.B.:** cooling of the circulating air in contact with the evaporator results in the water contained in the air condensing. The condensed water flowing down the back of the heat pump must be removed from it and conveyed into suitable plastic pipes.

On the basis of air humidity, **up to 0.5 l/h of condensate may be formed.** The condensate run-off must not be conveyed into the drain, since the ammonia fumes that flow back from the drain could damage the heat exchanger fins and parts of the heat pump.

**It is therefore obligatory to fit a siphon for the discharge of waste water (do not use the pipe supplied under any circumstances to make a siphon). This connection must not in any case be included in the safety unit.**

### 2.4 AIR INTAKE CONNECTION.

When the volume of the room where the boiler is installed is less than 20 m<sup>3</sup>, the appliance may be connected to air ducts with diameter 160 mm. If these ducts are not insulated, condensate might form in them during appliance operation.

**It is therefore essential to choose insulated air ducts** (Fig. 14).

Poor-quality air ducts (crushed, too long, or with too many bends, etc.) may cause a loss of performance.

**Flexible ducts are therefore definitely not recommended.**

**N.B.:** if there are connections to the ducts, adjust fan settings accordingly.

**N.B.:** the overall head loss on ducts and fittings for discharge and intake of air **must be less than 130 Pa.** Calculation of load losses must be made using the measurement instruments supplied by the manufacturer, in accordance with the proposed ducting accessories.

**N.B.:** adjustable outlets may allow the use of ducting bends to be reduced or dispensed with altogether. For additional information on adjustable outlets, see Parag. 2.2.

### 2.5 ELECTRICAL CONNECTION.

**Note:** the water heater can be electrically connected only after being filled with water.

**Note:** do not fit a programming clock or timing devices that may interrupt the device's power supply upstream of the water heater's electrical connection.

The water heater can be connected and operated only with single-phase 230V AC power supply. Connect the boiler with a cable having conductors with 2.5 mm<sup>2</sup> section. Installation shall consist of:

- a circuit breaker or 16A multi-pole fuse with contacts compliant with regulations in force.
- A 30 mA differential circuit breaker.

If the power cable is damaged, for safety reasons it must be replaced by the manufacturer, the after-sales service or similarly qualified staff.

**N.B.:** earthing is obligatory.

Do not connect the power supply directly to the electrical resistance.

The safety thermostat with which the electrical integration is fitted must not be tampered with; if required, it may be repaired/serviced exclusively by skilled and qualified staff, according to the instructions provided by Immergas.

**Failure to comply with this clause shall void the warranty.**

The appliance must be installed in compliance with the provisions of the regulations in force.

### Installation with connection to a Plus boiler (model “SOL”).

In the “SOL” version, the internal heat exchanger may be used in alternative to Solar connection, to connect a boiler.

There is a pre-arrangement for electrical connection to the boiler, to be made through terminals C1 and C2 (clean contact); this contact might be placed in series with the NTC probe connection of a Plus (although this will lead to DHW probe anomaly on the boiler - until there is no demand and the probe is therefore interrupted). The boiler is triggered with intake air temperatures outside the correct RAPAX operation range, or if the BOOST mode is active.



**Photovoltaic self-consumption contact.**

The water heater is equipped with a contact to fully exploit the electricity produced by the PV system, in order to accumulate thermal energy within the storage tank (self-consumption).





Having an inverter/electronic device which supplies a signal when PV production exceeds a certain value at least higher than 450W, when this contact is closed the boiler is triggered in heat pump mode to heat the DHW up to 62°C, as long as it is within the allowable ambient temperature values (-5°C +43°C).

When the photovoltaic contact is opened, the system goes back to the previous settings only after about 5 minutes, to avoid alternating operation caused by clouds or temporary shadows.

See the instructions for removing the front cover, and for access to the terminal block see paragraph 4.5.

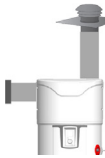
**N.B.:** A cable channel is provided specifically for this connection. Ensure it is used (Fig. 15).

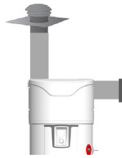
**LENGTH OF THE AUTHORISED SHEATH**

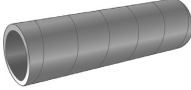
External/External Coating		Type configurations			
					
Air Outlets / Inlets		Roof	Wall-mounted Roof	Wall-mounted	Roof Wall-mounted
Max. Lengths L1 + L2	Isolated semi-rigid galvanic sheath Ø 160 mm 	12 m	12 m	5 m	10 m
	PEHD Sheath Ø 160 mm 	28 m	26 m	16 m	24 m

**N.B.:** the adjustable vents can allow to reduce or eliminate the use of coating elbows.



*The ducts must be fitted to the adjustable air intake and outlet vents.*

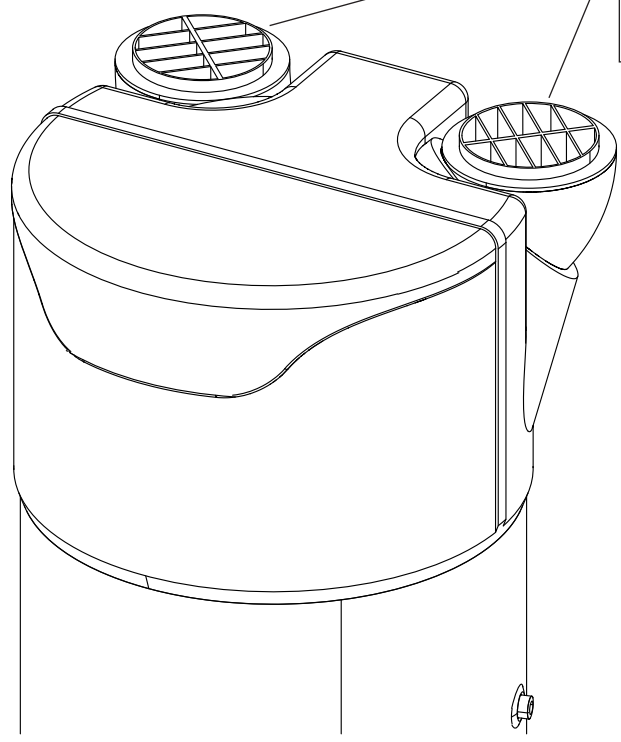

*Specific cable duct.*

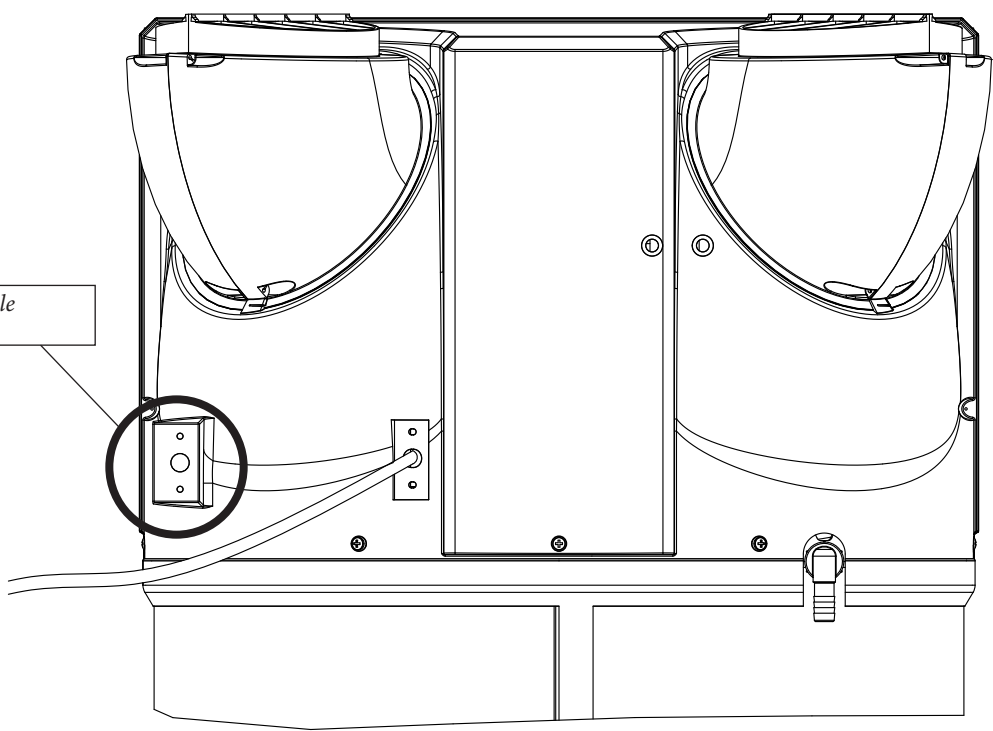

## 2.6 ELECTRICAL CONNECTION FOR PLUS BOILER AND PHOTOVOLTAIC SYSTEM.

N.B. Con questa configurazione la caldaia può mostrare un errore sulla sonda sanitaria

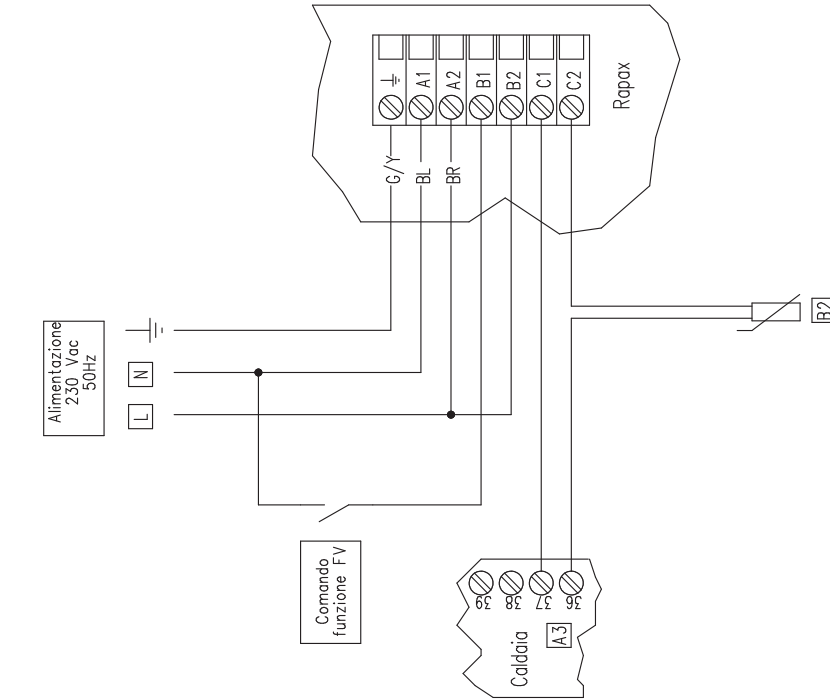

Key:  
 A3 - Integrated P.C.B.  
 B2 - DHW probe

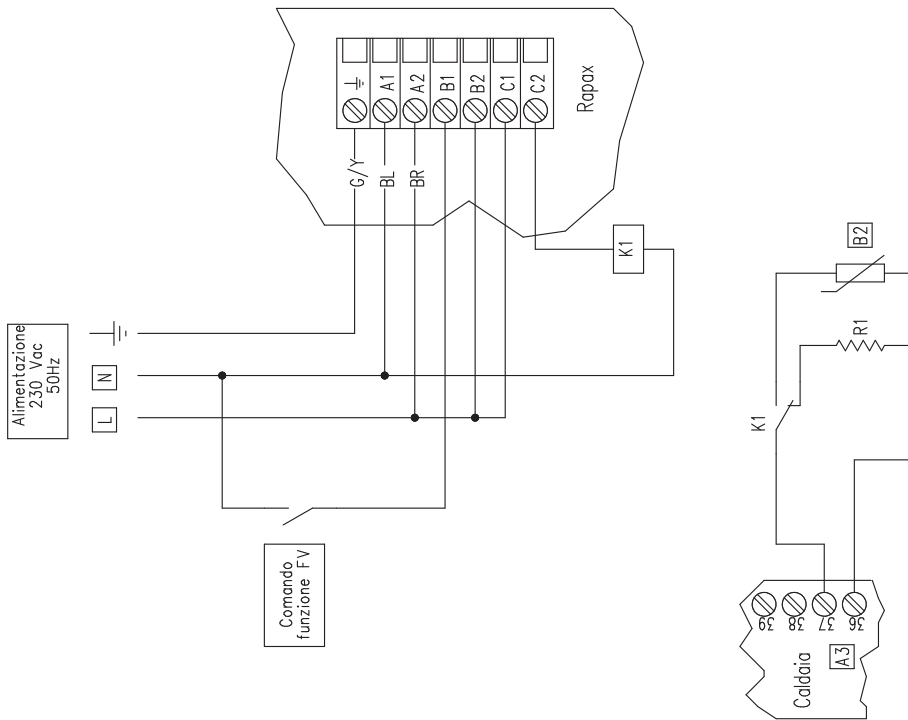

Key:  
 A3 - Integrated P.C.B.  
 B2 - DHW probe  
 K1 - Domestic hot water unabling relay  
 R1 - Resistance (2.2 KΩ)



**Probe housing for solar system or boiler (for SOL versions only) (Fig. 17):**

- 1- Pull out the plug and foam insert beside the internal exchanger.
- 2- Push the probe through the plug (if it has a suitable hole).
- 3- Insert the probe into the conduit, ensuring it is placed correctly at the bottom of the housing.
- 4- Put the foam insert back, and clip the plug onto the product.

**2.7 COMMISSIONING.**

**Filling the water heater.**

- Open the hot water taps.
- Open the cold water tap on the safety device (ensure the unit emptying valve is closed).
- Run the hot water from the taps then close them: the water heater is now full.
- Check water tightness of the pipe fittings.
- Check correct operation of hydraulic devices by opening the discharge valve of the safety device to eliminate any residues from inside the relief valve.

**Commissioning.**

**Note:** if the water heater has been tilted, wait at least 1 hour prior to commissioning.

- Turn on the water heater.
- Check that the screen (4 Fig. 20) does not display errors.
- During first power-up, the adjustment instructions are displayed on the screen. Follow the on-screen instructions carefully to set parameters (date and time, air ducts, language, recirculation, photovoltaic, operating time slots, anti-legionella system).
- After setting the parameters, check the operation of the water heater (see section “Operation check”).

To go back to the settings, refer to the paragraph “System settings” or “Installation parameters”.

**Operation check.**

The parameters can be accessed in INSTALLER MODE. Hold down the Menu button (2 Fig. 20) and turn the selector switch (1 Fig. 20) by a half turn to the right. To exit the installer mode, proceed in the same way or wait for 10 minutes.

Access settings → (MENU) → Test → Actuators.

The “TEST” menu allows you to start the actuators of the device in Forced mode.

Heat pump		Start of the fan then of the compressor
Fan	at low speed	Operation of the fan at low speed
	at high speed	Operation of the fan at high speed
Additional electric backup		Commissioning of electrical integration
Defrost		Starting of the fan, then the compressor and pop noise of the coil
Boiler integration		Sending the signal to the boiler to request hydraulic integration
Temperature sensors		Display of temperatures: Incoming air, High evaporator, Low evaporator, Return compressor, Hot water



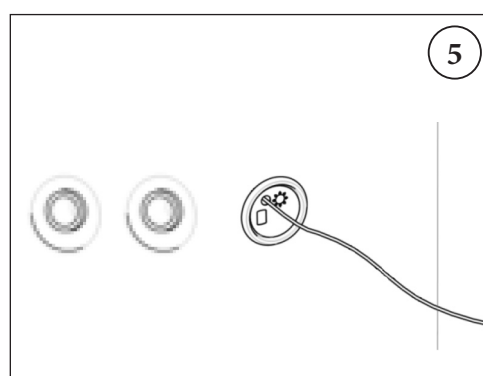
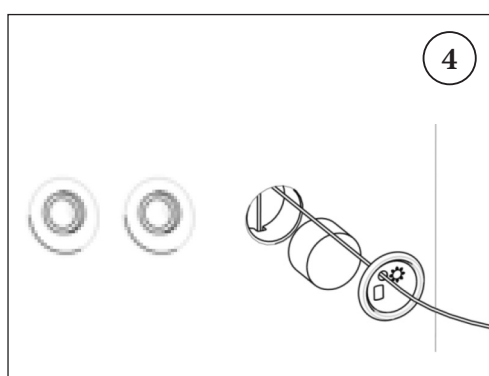
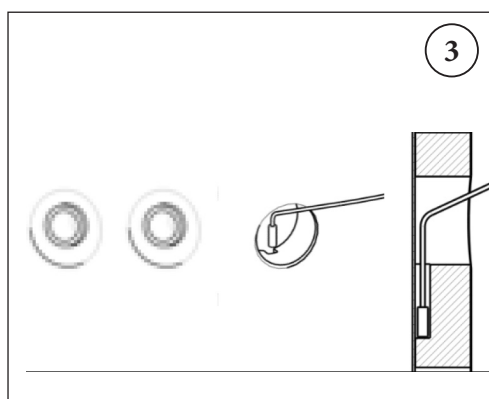
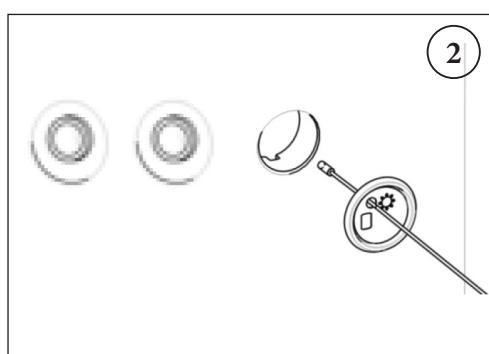
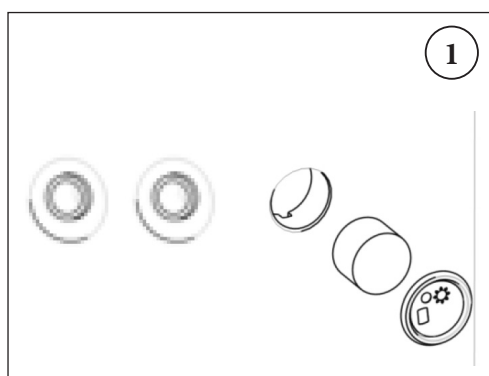

2.8 THERMAL SOLAR CONNECTION DIAGRAM (OPTIONAL).

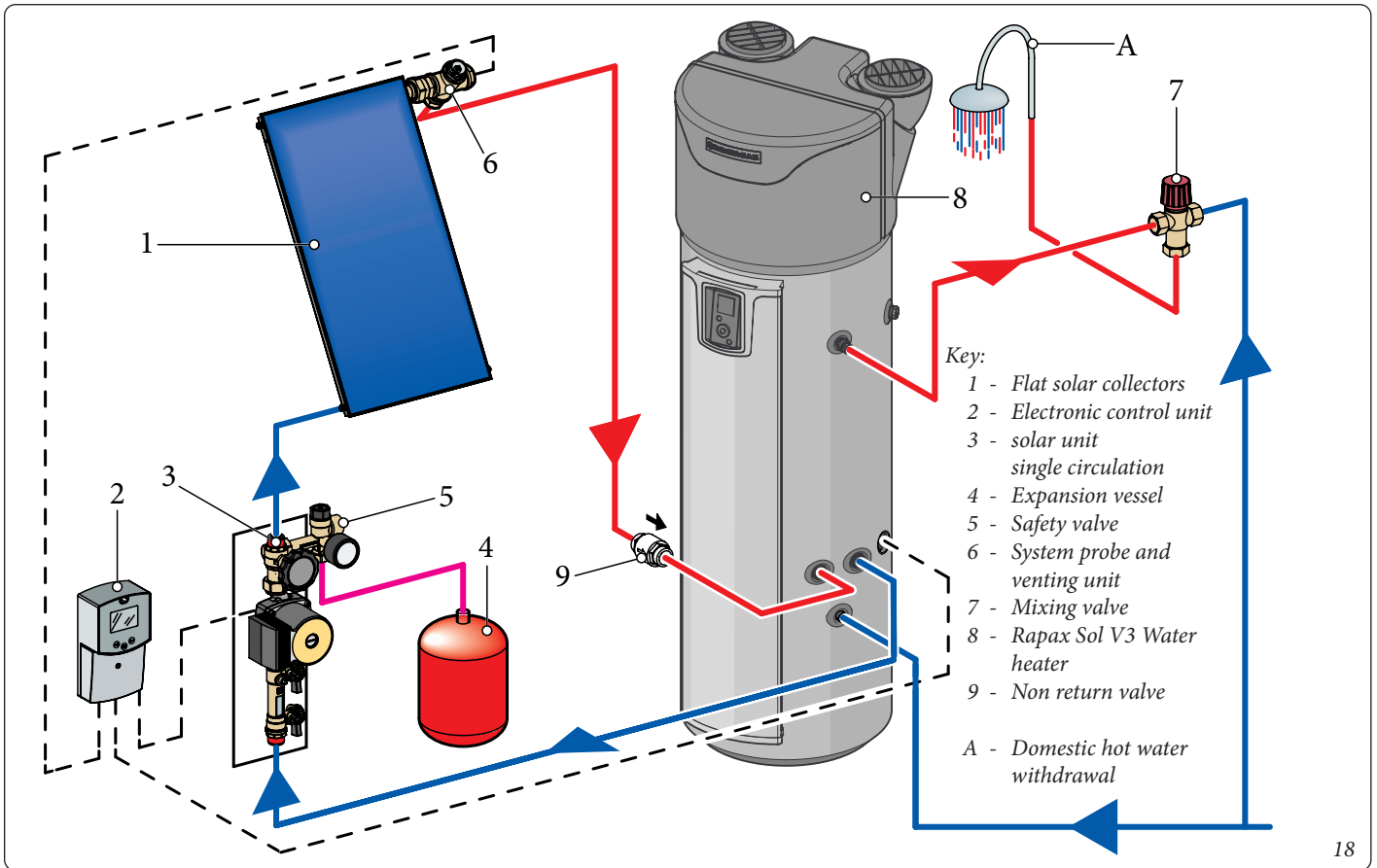

2.9 BOILER CONNECTION DIAGRAM (OPTIONAL)..

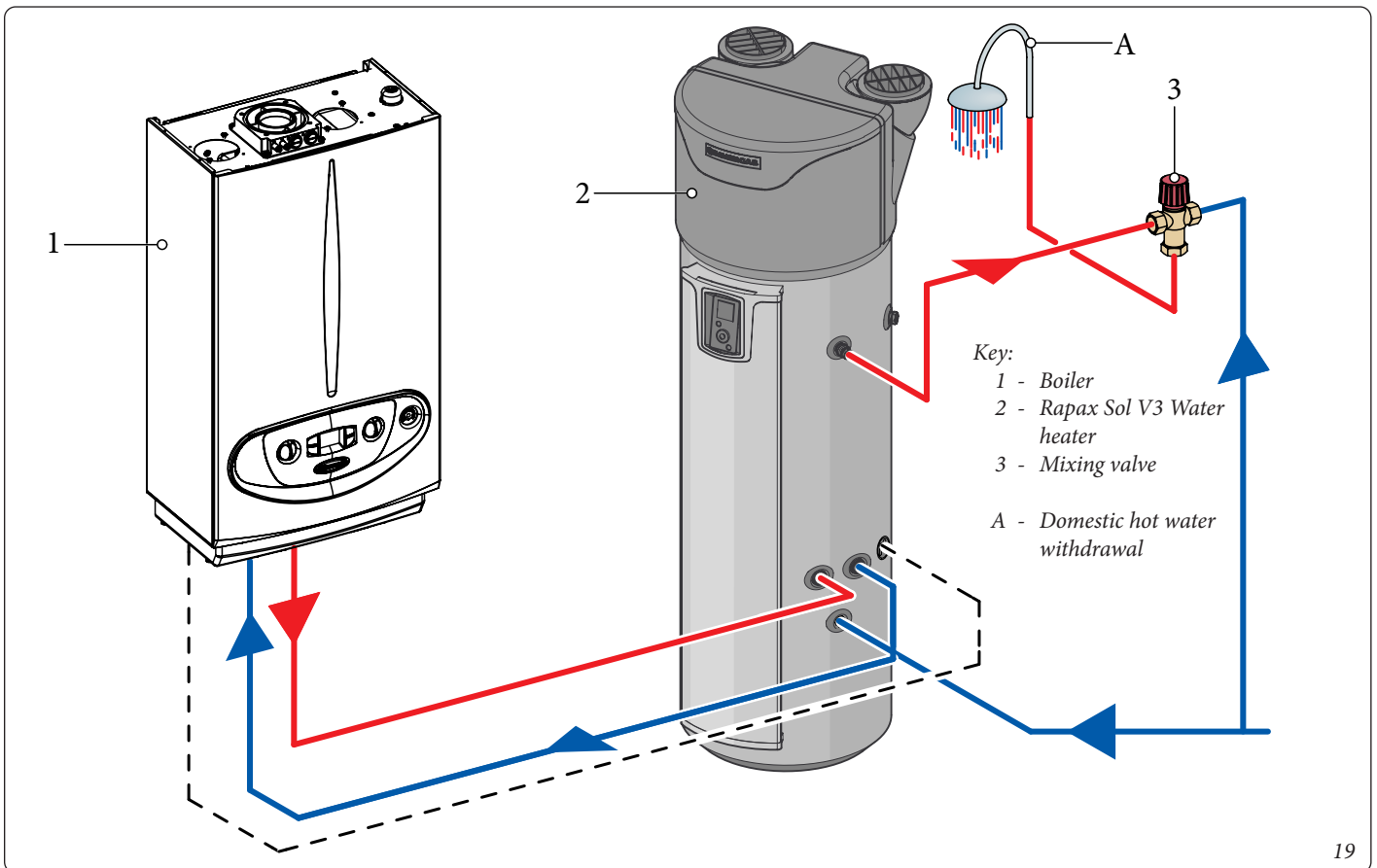



# 3 PARAMETER SETTINGS / USE

## 3.1 REMOTE PANEL.

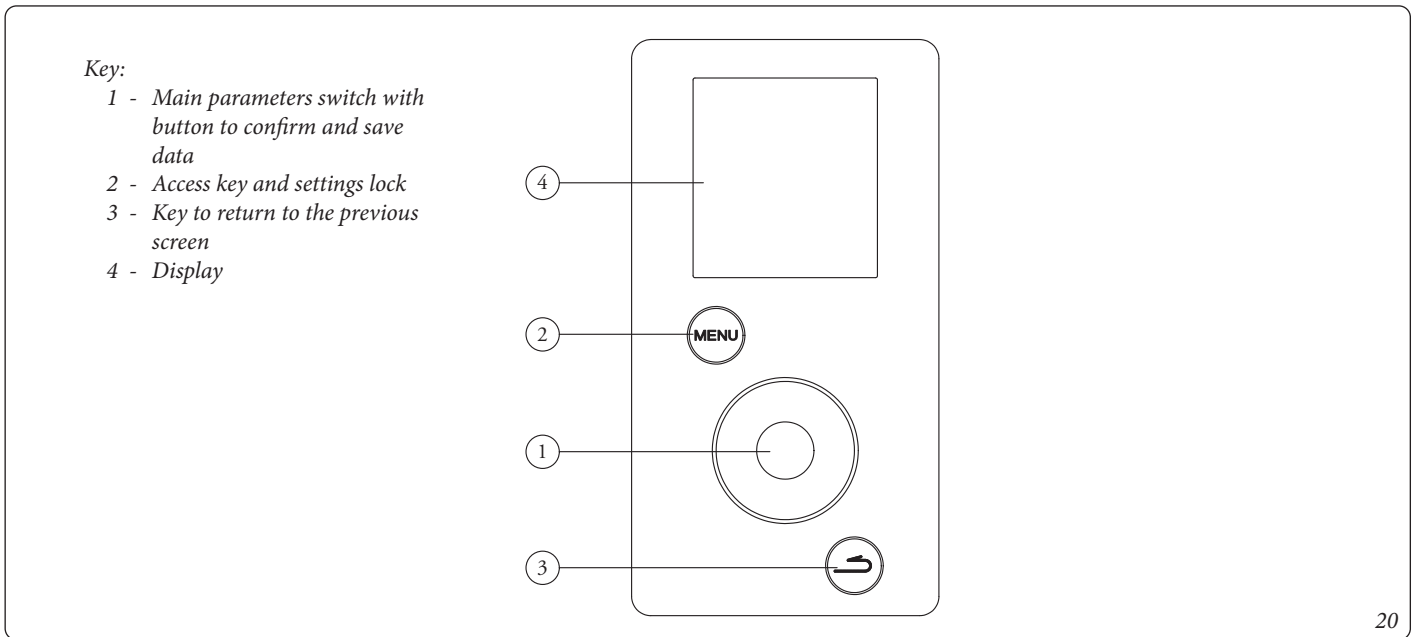

## 3.2 DESCRIPTION OF THE SYMBOLS.

Symbol	Description
<b>BOOST</b>	Forced start set
	Absence set / in progress
	Current hot water temperature
	Stand-by
	Warning
	Electrical integration in operation
	Heat pump in operation
	Boiler integration in operation
	Reception of a signal at the inlet of the solar system
	Reception of a signal at the inlet of the photovoltaic system / Smart Grid

## 3.3 MAIN MENU.

Access to the settings by pressing the “Access key and settings lock” (MENU) (2 Fig. 20) and follow the on-screen instructions (4 Fig. 20). Navigate the menu by turning the main switch (1 Fig. 20) to the left to decrease the values or to the right to increase the values. Press the main switch in the centre (1 Fig. 20) to confirm.



- **BOOST function (BOOST).**

Increase the production of hot water regularly. Set the number of the BOOST operation days (from 1 to 7). At the end of the chosen period, the water heater resumes operation with the initial settings. The BOOST can be interrupted at any time: **Pause the BOOST**.

- **OPERATING mode (☐).**

Choose the operating mode. Select AUTO or MANUAL (see paragraph 3.6 “Operating modes”).

- **ABSENCE mode (☐).**

Schedule an absence. It allows you to indicate in the water heater:

- a permanent absence starting from the current date;
- a programmed absence (set the start date of the absence and the end date). On the eve of your return, an anti-legionella cycle is activated. In this period, the water temperature is kept above 15°C. The function can be interrupted at any time: **Delete ABSENCE**.



- **Information (i).**

- Display the energy savings.  
It allows you to view the utilisation rate of the heat pump and electrical integration over the last 7 days, the last 12 months, from commissioning.
- Display the power consumption.  
It allows you to view energy consumption in kW/hour, in recent days, in recent months, in recent years.
- Display the budget parameters.  
It allows you to view all the settings recorded in the water heater.

- **Settings (wrench).**

- Set the time and date.  
Set the day and then confirm. Then set the month, year, hour and minutes.
- Set the operating time slots.  
It lets you define the time slots in which the device is authorised to start.
- Set the language.  
French, English, Dutch, Spanish, Portuguese, German, Italian and Polish.
- Electrical integration.  
It allows you to turn off the support of electrical integration.

### 3.4 SYSTEM SETTINGS.

Access the system settings again: (MENU) + **Settings**.

- **Date and time.**

Set the day and then confirm. Do the same for the month, year, hour and minutes.

- **Operation time.**

This parameter defines the operating time slots of the heat pump, of the electrical integration, and if present, of the hydraulic auxiliary device according to the hot water requirements:

**Permanent** Start at any time of the day.  
**Programming** Start only in scheduled periods.

Duration of the 1st slot: from 4 to 14 hours;  
Total duration of the 2 slots: minimum 8 hours and maximum 14 hours.

- **Language.**

Possible settings in French, English, Dutch, Spanish, Portuguese, German, Italian and Polish.

### 3.5 PARAMETERS TO BE ADJUSTED UPON INSTALLATION.

(If not set at the time of commissioning)

The parameters can be accessed in INSTALLER MODE.

Hold down the Menu button (2 Fig. 20) and turn the selector switch (1 Fig. 20) by a half turn to the right.

To exit the installer mode, proceed in the same way or wait for 10 minutes.

Access to the system settings: (MENU) **Settings**.

- **Air ducts (aeraulic operation).**

This parameter defines the aeraulic connection type realised:

Inner / Inner	Suction and return not connected to air ducts (ambient air)
Outer / Outer	I n t a k e a n d r e t u r n connected to air ducts (coated air)
Inner / Outer	Return connected to an air duct (semi-coated)

- **Installation options(for products with coil).**

Thermodynamic only	The indoor heat exchanger is not used
Connected to boiler	The indoor heat exchanger is connected to a boiler controlled through the device
Connected to solar sys.	The indoor heat exchanger is connected to a solar energy system

In “Connected to boiler” it is asked to define a preference relating to the operation of priorities between the boiler and the heat pump according to 4 levels:

Heat pump prioritised	The integration will be only active at the end of the heating for very low air temperatures (<7°C)
Heat pump optimised	The integration will be only active until the end of the heating and ± early depending on the air temperature
Boiler optimised	The heat pump is activated at the end of the heating and ± soon as a function of air temperature
Boiler prioritised	The heat pump is active at the beginning of heating and for air temperature >10°C.

- **PV system/Smart-grid.**

This parameter is used to activate the device coupled with a photovoltaic system. This operating mode generates the forced start of the heat pump when the water heater receives a signal coming from the photovoltaic system. The setting automatically returns to the previously selected mode after 5 minutes if the photovoltaic system signal is lost. While receiving the signal the set point temperature is automatically set at 62°C (not adjustable).

- **Exhaust air.**

It allows you to turn on the air extraction function (2 speeds: low or high). When the unit does not heat domestic water, the fan turns on to evacuate the ambient air to the outside (only activated when the aeraulic connection type is Inner/Outer).

- **Anti-legionella function.**

It allows you to turn on the water disinfection function adjustable from 1 to 4 times a month.  
The water temperature reaches 62°C during the cycle.

- **EMERGENCY mode.**

Enabling this mode allows continuous operation only with the electrical integration. The programming slots are not considered.



- **Additional electric backup.**

It allows you to activate or not the electrical integration support. If it is off, the device will never use the electrical integration; in case of low temperatures, a shortage of hot water is possible.

### 3.6 SELECTING THE OPERATING MODE.

Press (MENU) to access the **Mode** menu.

- **In AUTO mode (this mode is not available on the “Connected to boiler” and “Connected to solar sys.” systems).**

This operating mode automatically manages the energy choice that allows maximum savings while guaranteeing an adequate comfort in terms of hot water. The water heater analyses the consumption of the previous days to adapt the production of hot water according to needs. It reacts to unexpected events to ensure the hot water making relaunches during the day. Therefore, the set point temperature is automatically adjusted between 50 and 62°C according to the consumption profile. The Water heater operates preferably through the heat pump. The electrical integration can be automatically selected to ensure a sufficient volume of hot water.

**N.B.:** this mode is not available on the “Connected to the boiler” and “Connected to solar sys.” plants.

- **MANUAL mode.**

This mode allows you to define the desired amount of hot water by choosing the set point. This set point is also represented as an equivalence of number of showers (about 50 litres of hot water). The products complies with the operating slots defined through the user’s time programming.

If the ECO mode is not active, the water heater favours operation with heat pump only. However, if the air temperature is low or consumption remarkable, the electrical integration (or boiler) can be authorized as a support at the end of heating to reach the temperature set. If the ECO mode is active, the water heater works only with the heat pump with an air temperature ranging from -5 to +43°C. Therefore electrical integration is not authorised at the time of heating. This feature optimises the savings, but can cause hot water shortages. Regardless of the ECO adjustment, if the air temperature exceeds the operating time slots, the electrical integration will be automatically selected to ensure a sufficient volume of hot water.

**PLEASE NOTE:** the ECO active/non active modes are not available on “Connection to the boiler” plants.

**PLEASE NOTE:** MANUAL mode and “Connected to solar sys.” plants: this mode also allows the operation of the heat pump in addition to the solar system. The contemporary prolonged operation of the heat pump and of the solar system may damage the product. It is therefore necessary to allow the operation of the heat pump only in the absence of solar energy (use the time programming of the heat pump).

- **BOOST mode.**

This mode activates the heat pump and all other available sources of energy (if declared boiler integration, electrical integration) without considering the authorised periods of operation. The number of the BOOST operation days is adjustable from 1 to 7. The setpoint temperature (62°C) cannot be adjusted.

At the end of the chosen period, the water heater resumes operation with the initial settings.

The BOOST can be interrupted at any time.

- **ABSENCE mode.**

This mode maintains the domestic hot water temperature above 15°C using the heat pump. The boiler and electrical integrations can be activated if the heat pump is not available. The function can be interrupted at any time

- **CIRCULATION cycle.**

This mode allows the heat pump to operate continuously to reach the set point of 62°C. The integrations (if declared boiler and electric) are activated after 7 hours of heating with the heat pump.

### 3.7 LOCKING THE CONTROLS.

The pressure of the button (MENU), for a few seconds, allows you to lock/unlock the controls.

### 3.8 MODE IN “HEAT PUMP PRIORITISED” SYSTEM.

- **Auto.**

The set point temperature is automatically adjusted between 50 and 62°C according to the consumption profile of the previous days. The Water heater operates preferably through the heat pump. The electrical integration can be activated automatically as support.

- **MANUAL-ECO Off.**

The fixed set point temperature is adjusted between 50 and 62°C by the user. The Water heater operates preferably through the heat pump. The electrical integration can be automatically activated to ensure a sufficient volume of hot water.

- **MANUAL-ECO On.**

The fixed set point temperature is adjusted between 50 and 55°C by the user. The water heater operates exclusively with the heat pump to optimize the savings. The electrical integration is authorized for operation only when the air temperature exceeds the operating time slots.

### 3.9 MODE IN “CONNECTED TO BOILER” SYSTEM.

- **MANUAL.**

The fixed set point temperature is chosen by the user between 50 and 62°C (55°C if ECO is On). The Water heater operates preferably through the heat pump. The electrical integration can be automatically activated to ensure a sufficient volume of hot water. If the media by the boiler is not available (in the boiler stop, for example), the electrical integration will be activated.

- **”SMART Energy” function.**

A heat pump draws the energy available in the air and returns this energy in the hot water by heat exchange in the tank. The performance of a heat pump will then be higher with parameters that facilitate these exchanges of energy; that is to say with hot air and cold water temperature in the tank. Our product permanently calculates, depending on the air temperature and the water temperature, which energy is cheaper. This SMART Energy function can decide to start heating with the heat pump and reach the last degree with the boiler integration.

In addition, you can set the Smart Energy function with 4 different priority levels:



<b>Heat pump prioritised</b>	The integration will be only active at the end of the heating for very low air temperatures (< 7°C)
<b>Heat pump optimised</b>	The integration will be only active until the end of the heating and ± early depending on the air temperature
<b>Boiler optimised</b>	The heat pump is activated at the end of the heating and ± soon as a function of air temperature
<b>Boiler prioritised</b>	The heat pump is active at the beginning of heating and for air temperature equal to >10°C

### 3.10 MODE IN “CONNECTED TO SOLAR SYS.” SYSTEM

The water heater only operates outside the solar energy production periods (when it receives a signal from the solar station). During sun production periods the production of hot water is realized by the internal heat exchanger therefore the heat pump and the electric integration are inactive.

- **MANUAL-ECO Off**

The fixed set point temperature is adjusted between 50 and 62°C by the user. The Water heater operates preferably through the heat pump. The electrical integration can be automatically activated to ensure a sufficient volume of hot water.

- **MANUAL-ECO On**

The fixed set point temperature is adjusted between 50 and 55°C by the user. The water heater operates exclusively with the heat pump to optimize the savings. The electrical integration is authorized for operation only when the air temperature exceeds the operating time slots.

**N.B.:** the electrical integration will never work if the “Connected to solar sys.” is Off.

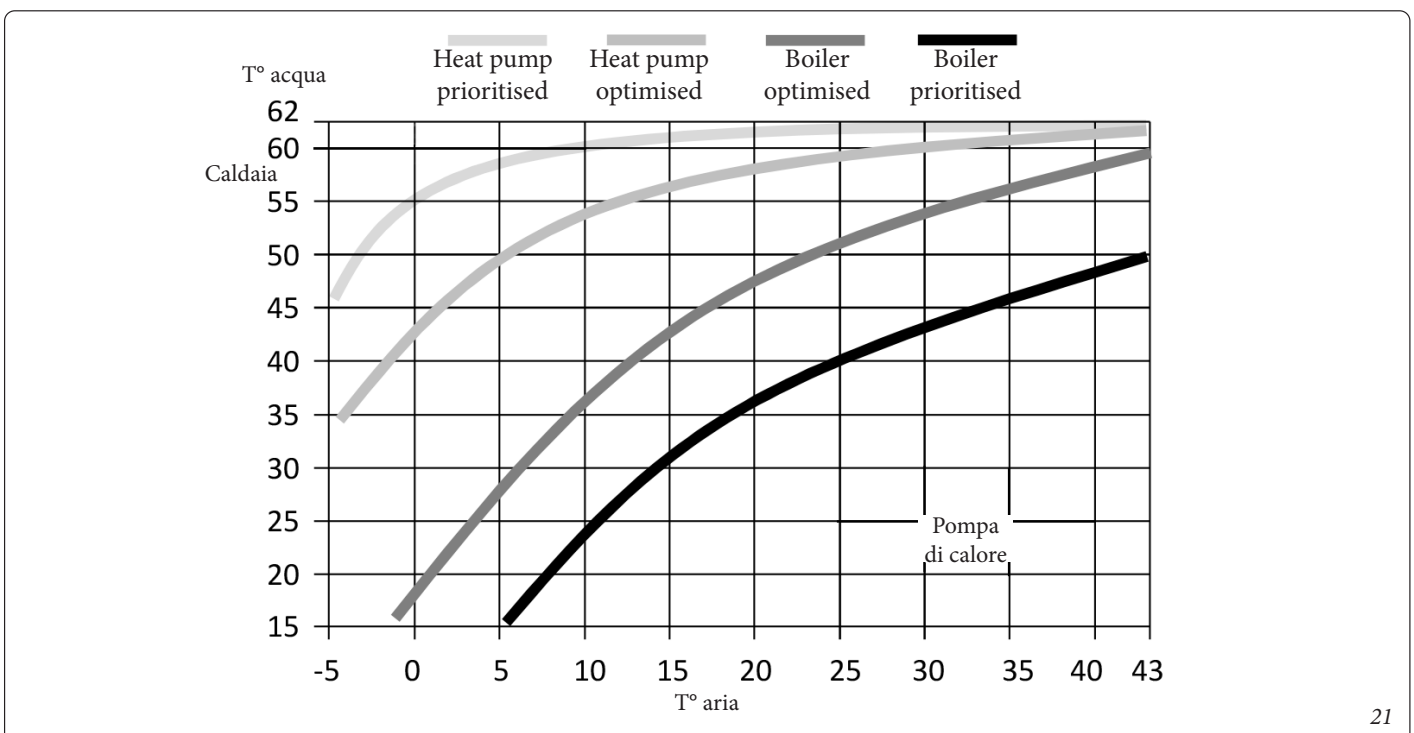

# 4 RECOMMENDATIONS - MAINTENANCE AND REPAIRS

## 4.1 ADVICE FOR THE USER.

You must empty the water heater if the absence mode cannot be used or when the device is powered down. Proceed in the following way:

- Cut the power supply.
- Close the cold water inlet tap.
- Open a hot water tap.
- Put the safety valve in the drain position.

### Important note - End of the device's service life:

- At the end of its service life, the device must be taken to a sorting centre for electrical and electronic equipment for recovery of fluids. Do not dispose of the device with household waste, but dispose of it in the collection centres provided, where it can be recycled. Check your local collection service to find out about existing waste collection centres.



- It is forbidden by law to discharge into the atmosphere the cooling fluid contained in the appliance. Degassing operations are strictly forbidden, and may be hazardous.

**N.B.:** the GWP (Global Warming Potential) of R513A is 631.

## 4.2 HOUSEHOLD MAINTENANCE.

The user must perform some minor home maintenance operations on the water heater: act on the safety valve once or twice a month to remove any limestone deposits and ensure it is not blocked.

Regularly check that there are no alarms on the display. If there are any alarms, contact the authorised local service centre to address the faults.

It is recommended to treat water with a softener in the areas where there is a high amount of scale ( $T_h > 20^\circ\text{f}$ ). **Water hardness must remain above 15°f.** The softener does not lead to warranty derogations, provided it is dosed in a workmanlike manner and regularly maintained.

Water treatment must comply with the National/local provisions in force.

## 4.3 MAINTENANCE BY APPROVED PROFESSIONALS.

**The appliance must be checked by a professional every year, in order to ensure its long-term performance**

- Disconnect the appliance from the electricity (circuit-breaker, fuses, etc.)
- Drain the tank:
  - close the cold water inlet tap of the safety unit,
  - open a hot water tap,
  - put the safety valve in the drain position.
- Remove the front cover.
- Disconnect the wires from the thermostat terminals.
- Dismantle the heating unit.
- Replace the magnesium anode. The magnesium anode has to be changed every 2 years or as soon as its diameter is less than 10mm.
- Remove the scale deposited as sludge or flakes in the bottom of

the tank, and carefully clean the casings of the heating elements and thermostat. Do not scratch or remove the scale attached to the walls, as this could affect the coating. Residues may be removed using a water and dust vacuum cleaner.

- Refit the heating unit with a new seal, carefully and gradually tightening the nuts (cross-tightening).
- Fill the water heater by leaving a hot water tap open, if the water flows it indicates that the water heater is full.
- Check the water tightness of the seal and only then replace the thermostat and its fittings, and reconnect the power supply.
- The next day, check the water tightness of the seal again and gently tighten the nuts again if necessary.
- Check the electrical connections.
- Check that the temperature probe is properly positioned in the sample point near to the electrical integration (the probe must be at the bottom of the sample point).

### Evaporator:

- The cleanliness of the evaporator and the fan must be checked **every year**. Clogging of these components may reduce the performance of the heat pump.
- Unscrew and remove the front cover to access the evaporator. The rear cover may also be removed if necessary.
- If necessary, the evaporator and the fan are to be cleaned with a soft bristle brush. Brush the evaporator very gently to avoid damaging its fins. If the fins are folded, straighten them using a suitable brush.

**Note:** always disconnect the device from the power supply before starting any work.

### Expansion valve:

- Only a refrigeration engineer is permitted to access the expansion valve adjustment screw. If the expansion valve is adjusted without approval from the manufacturer, the product warranty shall be voided.
- Generally speaking, it is not recommended to change the expansion valve setting before all other repair solutions have been exhausted.

### Condensate draining pipe:

- Check cleanliness of the condensate evacuation pipe. Any pollution (dust) in the room may in fact cause deposits in the condensate recovery tank. These deposits may block the condensate evacuation tube, and cause excessive accumulation of water in the tank, which could lead to malfunctions.



#### 4.4 TROUBLESHOOTING SUPPORT.

##### Control panel alarm codes

Errors can be suspended or reactivated by pressing “OK”.

This action also stops the buzzer.

Error Code	Cause	Consequences	System status / Solution
03	<b>Faulty water temperature probe or out of measurement range</b>	Water temperature reading impossible: no central heating / C.H.	Check the connection (reference A1) of the water temperature probe (sample point). Check the resistance of the probes (see table below). If necessary, replace the probe.
07	<b>No water in the storage tank or ACI connection open</b>	No warming up.	Put the storage tank in the water. Check the thread connection (reference AC), conductivity of the water.
09	<b>Water temperature too hot (T&gt; 80°C)</b>	Risk of mechanical safety device activation: no central heating / C.H.	Check if the real water temperature at the sample point is high (T>80°C). Check the connection (reference A1) and the positioning of the water temperature probe (sample point), it must be at end run. Check that the electrical integration is not permanently fed. Reset the mechanical safety, if necessary.
12	<b>Water temperature too cold (T&lt; 5°C)</b>	PDC stoppage. Central heating / C.H. in ELEC.	Automatic resetting as soon as T>10°C. Check installation compliance (room protected against freezing).
15	<b>Date and time not set</b>	PDC Se PROG stop	Enter date and time.
21	<b>Faulty air inlet probe or out of measurement range (from -20 to 60°C)</b>	PDC stoppage. Central heating / C.H. in ELEC.	Check the connections (reference A4) and the positioning of the inlet air probe. Check the resistance of the probes (see table below). If necessary, replace the probe bundle. After solving the fault, the heat pump will be restored within 2 hours.
22,1	<b>Faulty high evaporator probe or out of measurement range (from -20 to 110)</b>	PDC stoppage. Central heating / C.H. in ELEC.	Check the connections (reference A4) and the correct application of the probe on the pipe. Check the fan operation and that it turns freely without stopping (reference M1) and the power supply on the terminal board. Check the resistance of the probes (see table below).
22.2	<b>Faulty low evaporator probe or out of measurement range (from -20 to 110)</b>	PDC stoppage. Central heating / C.H. in ELEC.	Check the connections (reference A4) and the correct application of the probe on the pipe. Check the fan operation and that it turns freely without stopping (reference M1) and the power supply on the terminal board. Check the resistance of the probes (see table below).



Error Code	Cause	Consequences	System status / Solution
25	<b>Compressor thermal safety or pressure switch opening</b>	PDC stoppage. Central heating / C.H. in ELEC.	Check the connections of the compressor (Reference R1), of the pressure switch, of the starting condenser (15mF) and of the hot gas valve (Reference T2). Check the resistances of the compressor coils.
28	<b>Defrosting system error</b>	PDC stoppage. Central heating / C.H. in ELEC.	Check the evaporator cleanliness Check the R513A fluid load (appliance de-frosted). Check the fan operation (reference M1) and the power supply on the terminal board. Check the condensate drain. Check the hot gas valve connections (reference T2) and its operation (TEST menu).
W.30.1	<b>Inefficient PDC heating</b>	PDC stoppage. Central heating / C.H. in ELEC.	Check the load. Check the ventilation operation (reference M1) and the power supply on the terminal board
W.30.2	<b>Inefficient PDC heating</b>	PDC stoppage. Central heating / C.H. in ELEC.	Check the load. Check the ventilation operation (reference M1) and the power supply on the terminal board
W.30.3	<b>Faulty pressure reducer</b>	PDC stoppage. Central heating / C.H. in ELEC.	Check that there is no frost on the pipe between the pressure reducer and the evaporator. Check the load. If it is charged, replace the pressure reducer.

Temperature / ohmic values correspondence table for air, evaporator and product sample point probes (CTN 10kΩ).

Temperature in °C																				
-20	-15	-10	-5	0	5	10	15	20	25	30	35	40	45	50	55	60	65	70	75	80
97.9	73.6	55.8	42.7	32.9	25.5	20	15.8	12.5	10	8	6.5	5.3	4.4	3.6	3	2.5	2.1	1.8	1.5	1.3
Resistance in kΩ																				



#### 4.5 WORK ON THE WATER HEATER.

##### Remove the front cover of the heat pump.

**Note:** always disconnect the device from the power supply before starting any work.

Remove the four screws from the cover with a screwdriver (Fig. 22).

##### Remove the rear cover of the heat pump.

**Note:** always disconnect the device from the power supply before starting any work.

**N.B.:** this operation is only needed for complex operations: (cleaning the evaporator, works on the fan, works on the compressor, etc.).

**N.B.:** it is essential to disconnect the power cable on the terminal board, so that the rear cover of the heat pump can be removed (Fig. 23).

Remove the five screws from the cover with a screwdriver (Fig. 24).

##### Access to the auxiliary electric unit of the water heater (Fig. 25).

To access the auxiliary power unit, proceed as follows:

- Remove the lower tap of the column releasing it,
- Unscrew the 2 fastening screws on each side of the column,
- Slide the column down a few centimetres to free it from the console,
- Press the centre of the column to open it and release it from the guide rails.

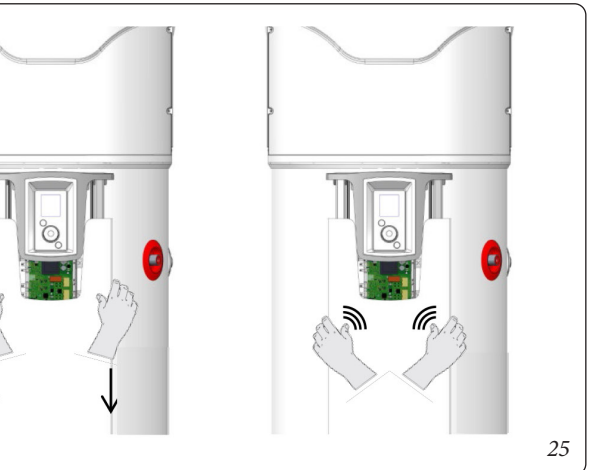
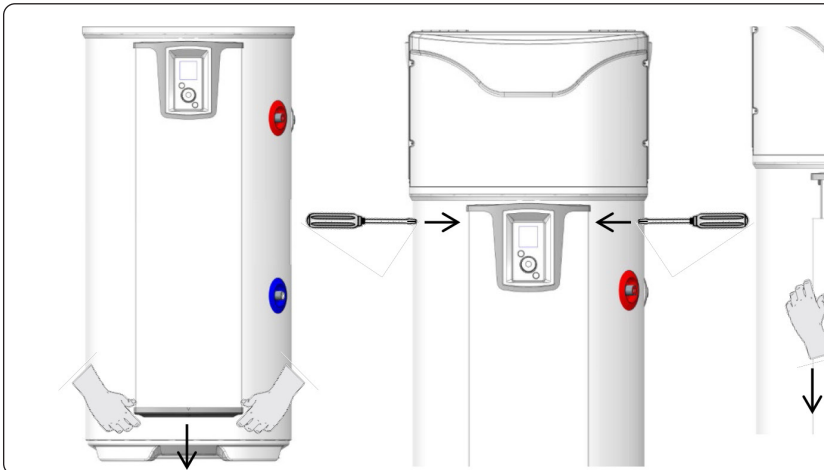
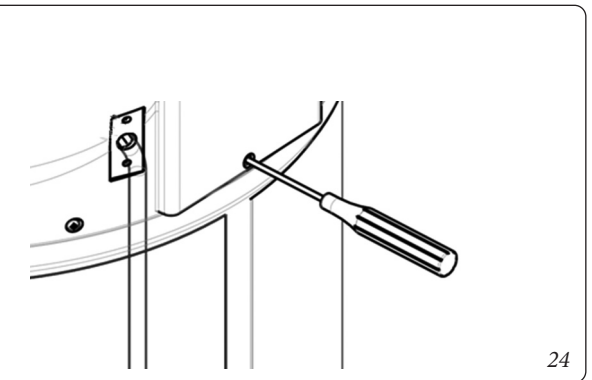
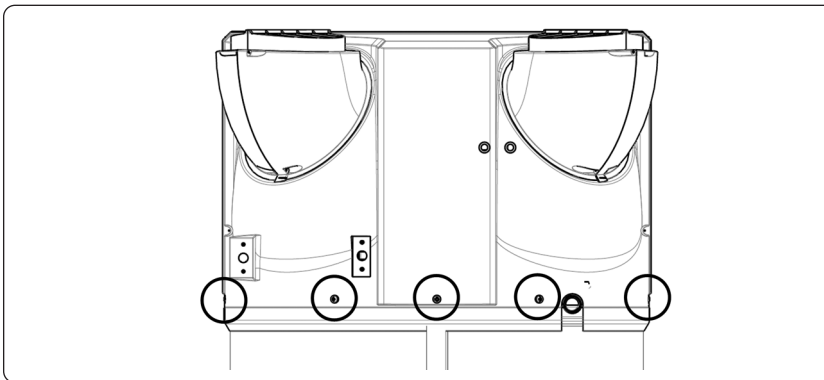
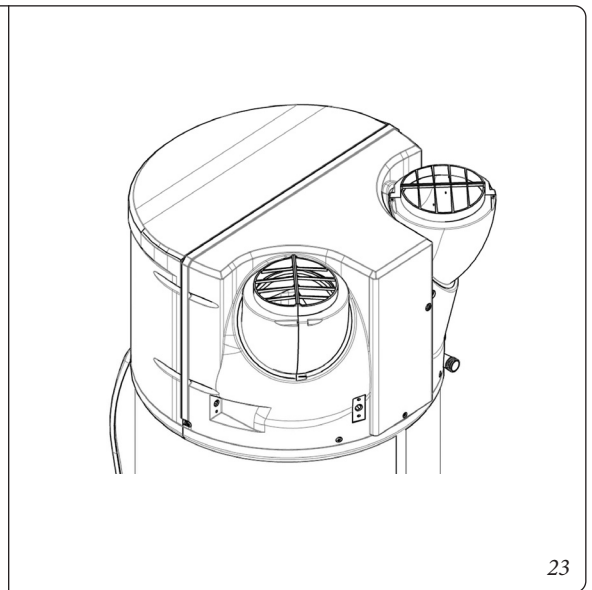
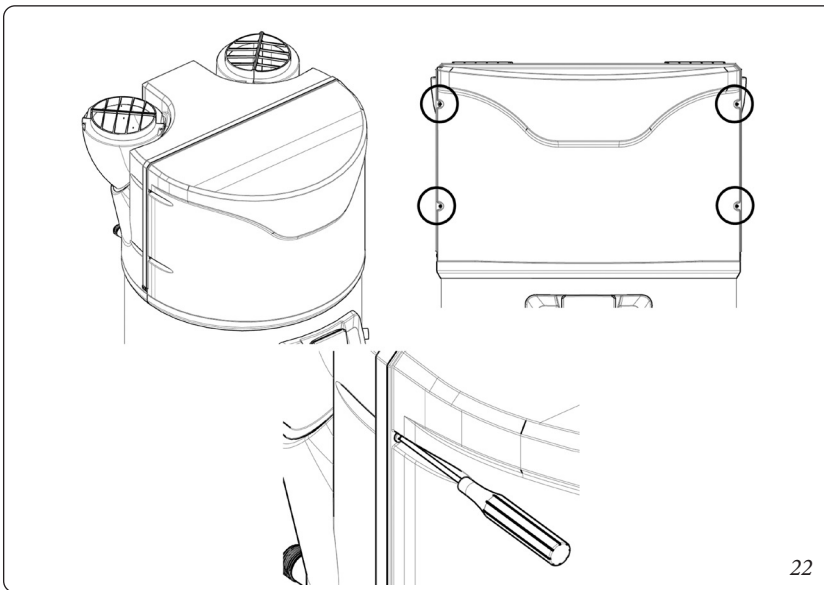



#### 4.6 QUICK FAULT DIAGNOSIS FOR USE CARRIED OUT BY A PROFESSIONAL TECHNICIAN.

Fault detected	Possible cause	Diagnosis and solution
<b>Insufficiently hot water.</b>	The main power supply of the water heater is not permanent.	Check that the appliance power supply is permanent. Check the absence of cold water return on the hot water circuit (faulty mixer possible).
	Temperature setpoint adjustment too low.	Set the setpoint temperature higher.
	ECO mode selected and air temperature out of range.	Select the AUTO mode. Check the duration of the programming intervals.
	Heating element or its wiring partially out of service.	Check the resistance on the bundle connector and the bundle condition. Check the safety thermostat.
<b>More central heating / C.H. No hot water.</b>	No water heater electric power supply: fuse, wiring...	Check for voltage on the power supply wires. Check the system settings (see the operating slots).
<b>Insufficient amount of hot water at max setpoint (62°C).</b>	Under-sizing of the water heater	Check the duration of the programming slots.
	ECO operation	Select the AUTO mode
<b>No flow rate at the hot water tap.</b>	Blocked safety unit filter.	Clean the filter (see maintenance chapter).
	Encrusted water heater.	Descale the water heater.
<b>Continued water leak to the level of the safety unit outside the heating period.</b>	Safety valve damaged or clogged.	Replace the safety unit
	Network pressure too high	Check that the outlet pressure of the water meter does not exceed 0.5 MPa (5 bar), otherwise install a pressure reducer set at 0.3 MPa (3 bar) at the beginning of the main water distribution.
<b>The heat pump does not work.</b>	Air temperature off range.	Automatic restart every 2 hours.
	Pump status outside the safety temperature operating area.	Automatic restart, normal product operation.
<b>The electrical integration does not work.</b>	Securing the mechanical thermostat.	Reset the thermostat safety to resistance level.
	Faulty electrical thermostat.	Replace the thermostat.
	Faulty resistance.	Replace the resistance.
<b>Condensate leakage.</b>	Blocked condensate drain.	Clean.
<b>Odour.</b>	No siphon on the safety unit or at the condensate drain.	Install a siphon.
	No water in the safety unit siphon.	Fill the siphon.
<b>Control panel fault or display problem.</b>	No power supply.	Check the power supply. Check the connection (reference A3).
	Display error.	Replace the display.

**N.B.:** Do not connect the power supply directly to the electrical resistance.

After maintenance or repair, check the correct operation of the water heater.



#### 4.7 AFTER-SALES SERVICE.

Only use original spare parts. Specify the exact type of boiler and serial number for any order.

#### Operations on electrical parts must be performed by skilled and qualified personnel pursuant to legislation in force.

If the power cable is damaged, for safety reasons it must be replaced by the after-sales service or similarly qualified staff.

#### 4.8 SCOPE OF APPLICATION OF THE WARRANTY.

The following faults are excluded from this warranty:

##### • Abnormal environmental conditions:

- various damage caused by impact or falling during handling after leaving the factory.
- Placement of the device in a location subject to frost or bad weather (humidity, aggressive or poorly ventilated rooms).
- Use of water whose features do not comply with those set forth by the regulations in force on the matter.
- Water pressure above 0.5 MPa (5 bar).
- Electrical power with significant voltage peaks (mains, lightning, etc.).
- Damage from undetectable problems caused by choice of location (places difficult to access) and that could have been avoided if the device had been repaired immediately.

##### • System does not comply with regulations, standards, professional rules, especially:

- missing or incorrectly fitted new safety unit, modification of calibration, etc.
- Insulating sheath (cast iron, steel or insulating) missing on hot water connection pipes, which could cause their corrosion.
- Faulty electrical connection: incorrect earthing, inadequate cable section, connection of flexible cables without metal terminals, failure to comply with the wiring diagrams provided by the Manufacturer.
- Switching on the device without first filling it (dry heating).
- Positioning the appliance without considering the instructions in the manual.
- External corrosion caused by poor sealing on pipes.

##### • Incorrect maintenance:

- abnormal scaling of heating elements or safety units.
- No maintenance of safety unit, leading to excessive pressure.
- No maintenance on magnesium anode (magnesium anode diameter must be at least 10 mm).

- No cleaning of evaporator or condensate evacuation.
- Modification of original equipment, without notifying the manufacturer, or use of spare parts not recommended by the manufacturer.

#### 4.9 DECLARATION OF CONFORMITY.

The appliance complies with the following directives:

- 2014/30/EU (EMC);
- 2014/35/EU (LVD);
- 2011/65/EU (RoHS 2);
- 2013/814/EU (Ecodesign);
- 2009/125/EC (Ecodesign).

If the safety device is activated, before carrying out any operation, disconnect the power supply and have the switch reset by a qualified technician.

If required, the declaration of conformity is available at the manufacturer's premises.

- This appliance has been designed to serve one residential Housing Unit only (and similar) subject to assessment of the energy requirement for domestic hot water; it is not a heating system pursuant to the legislation in force.



# 5 PRODUCT FICHE (IN COMPLIANCE WITH REGULATION 812/2013).

Rapax 200 V3

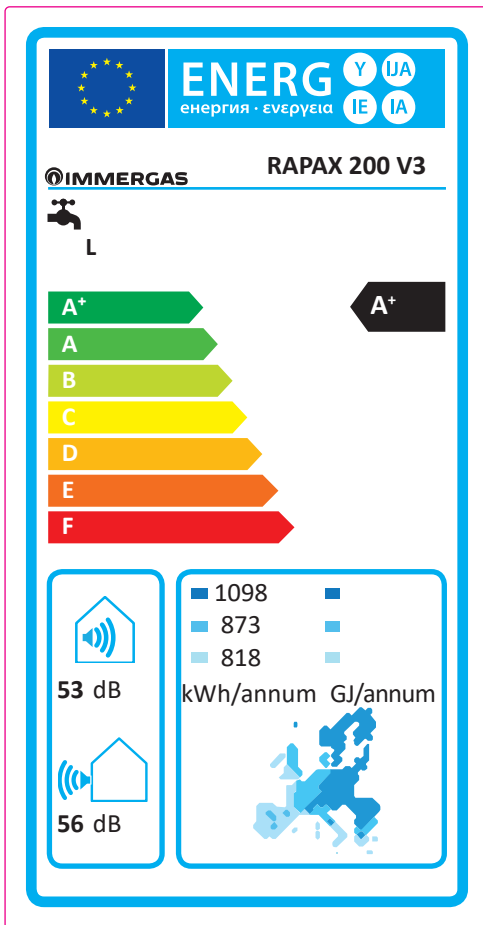

Rapax 200 Sol V3

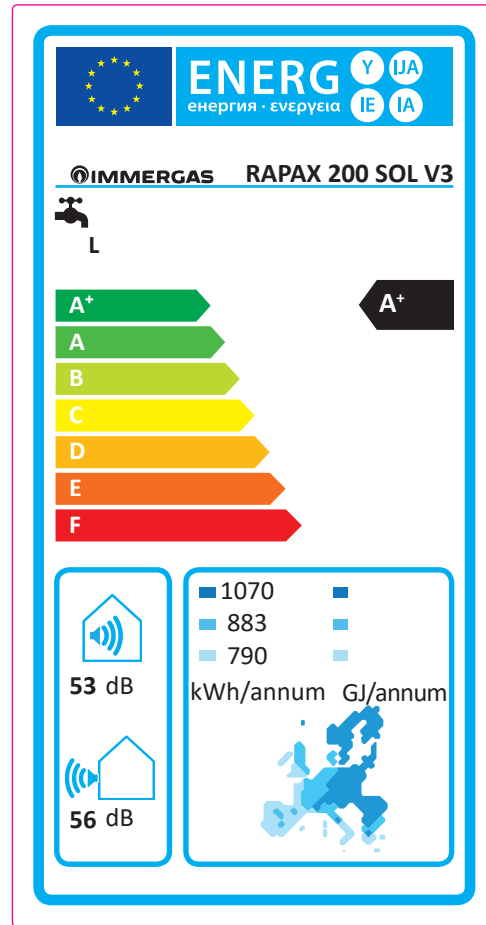

Parameter	value
Energy efficiency in average climate conditions	117 %
Energy efficiency in colder climate conditions	93 %
Energy efficiency in warmer climate conditions	125 %
Annual energy consumption in average climate conditions	873 kW/h
Annual energy consumption in colder climate conditions	1098 kW/h
Annual energy consumption in warmer climate conditions	818 kW/h
Thermostat temperature	54 °C
Daily electrical power consumption	4,150 kW/h
V40	267 L

Parameter	value
Energy efficiency in average climate conditions	116 %
Energy efficiency in colder climate conditions	96 %
Energy efficiency in warmer climate conditions	130 %
Annual energy consumption in average climate conditions	883 kW/h
Annual energy consumption in colder climate conditions	1070 kW/h
Annual energy consumption in warmer climate conditions	790 kW/h
Thermostat temperature	54 °C
Daily electrical power consumption	4,190 kW/h
V40	262 L

For proper installation of the appliance refer to chapter 2 of this booklet (for the installer) and current installation regulations. For proper maintenance, refer to chapter 4 of this booklet (for the maintenance technician) and adhere to the frequencies and methods set out herein.

For proper installation of the appliance refer to chapter 2 of this booklet (for the installer) and current installation regulations. For proper maintenance, refer to chapter 4 of this booklet (for the maintenance technician) and adhere to the frequencies and methods set out herein.



## Rapax 300 V3

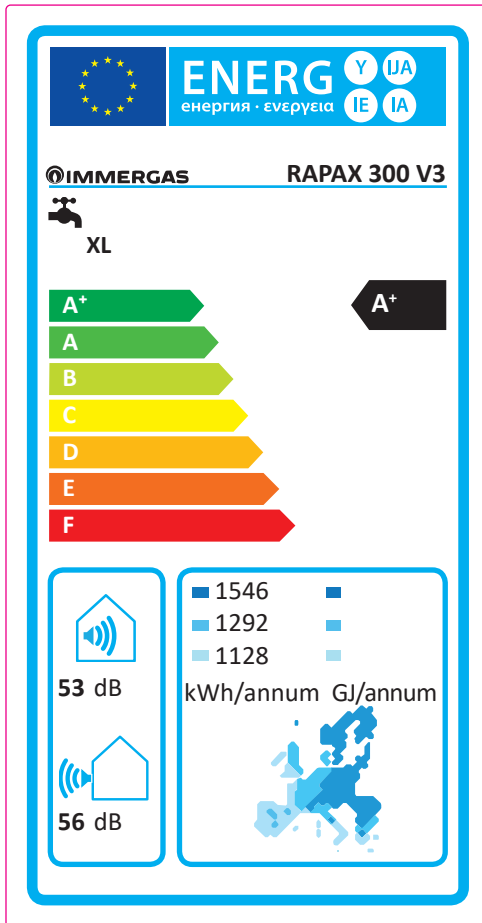

Parameter	value
Energy efficiency in average climate conditions	127 %
Energy efficiency in colder climate conditions	103 %
Energy efficiency in warmer climate conditions	152 %
Annual energy consumption in average climate conditions	1292 kWh/h
Annual energy consumption in colder climate conditions	1546 kWh/h
Annual energy consumption in warmer climate conditions	1128 kWh/h
Thermostat temperature	54 °C
Daily electrical power consumption	6.170 kW/h
V40	341 L

For proper installation of the appliance refer to chapter 2 of this booklet (for the installer) and current installation regulations. For proper maintenance, refer to chapter 4 of this booklet (for the maintenance technician) and adhere to the frequencies and methods set out herein. .

## Rapax 300 Sol V3

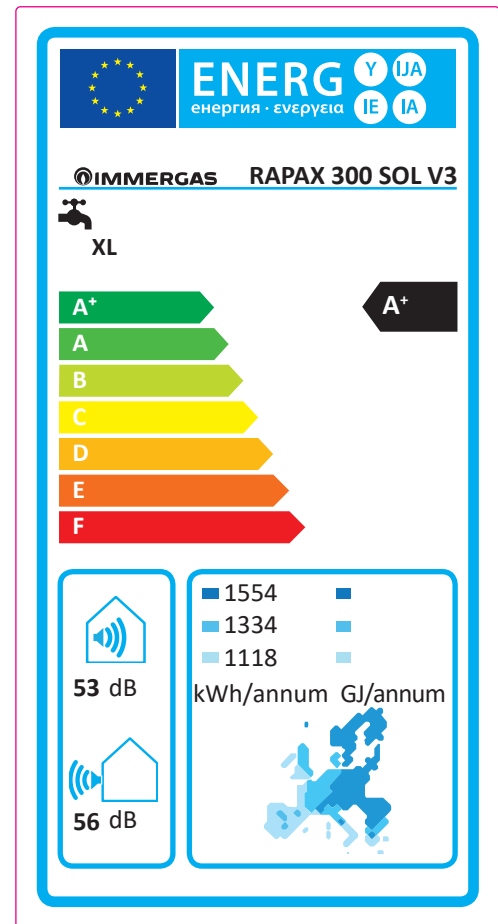

Parameter	value
Energy efficiency in average climate conditions	124 %
Energy efficiency in colder climate conditions	100 %
Energy efficiency in warmer climate conditions	141 %
Annual energy consumption in average climate conditions	1334 kWh/h
Annual energy consumption in colder climate conditions	1554 kWh/h
Annual energy consumption in warmer climate conditions	1118 kWh/h
Thermostat temperature	54 °C
Daily electrical power consumption	7.160 kW/h
V40	333 L

For proper installation of the appliance refer to chapter 2 of this booklet (for the installer) and current installation regulations. For proper maintenance, refer to chapter 4 of this booklet (for the maintenance technician) and adhere to the frequencies and methods set out herein.



# 6 PARAMETERS FOR FILLING IN THE PACKAGE FICHE.

Should you wish to install a unit, starting from the heat pump boiler Rapax 200-300 V3 or Rapax 200-300 Sol V3, use the diagram shown on Fig. 28.

To complete it properly, fill the relevant spaces (as shown in the assembly sheet facsimile Fig. 26) with the values shown in tables Fig. 27.

The remaining values must be obtained from the technical data

sheets of the products used to make up the assembly (e.g. solar devices, integration heat pumps, temperature controllers).

Use board Fig. 28 for “assemblies” related to the domestic hot water function (e.g.: water heater + solar thermal system).

## Facsimile for filling in the domestic hot water production system package fiche.

Water heating energy efficiency of the water heater

<sup>1</sup>  
 %

Stated load profile:

Solar contribution

From the board of the solar device

Auxiliary electricity

$$(1.1 \times \text{'I'} - 10\%) \times \text{'II'} - \text{'III'} - \text{'I'} + \text{'2'} \% =$$

Water heating energy efficiency of the assembly in average climate conditions

<sup>3</sup>  
 %

Water heating energy efficiency class of the assembly in average climate conditions

	<input type="checkbox"/>	<input type="checkbox"/>	<input type="checkbox"/>	<input type="checkbox"/>	<input type="checkbox"/>	<input type="checkbox"/>	<input type="checkbox"/>	<input type="checkbox"/>	<input type="checkbox"/>	<input type="checkbox"/>
	G	F	E	D	C	B	A	A <sup>+</sup>	A <sup>++</sup>	A <sup>+++</sup>
<input type="checkbox"/> M	< 27 %	≥ 27 %	≥ 30 %	≥ 33 %	≥ 36 %	≥ 39 %	≥ 65 %	≥ 100 %	≥ 130 %	≥ 163 %
<input type="checkbox"/> L	< 27 %	≥ 27 %	≥ 30 %	≥ 34 %	≥ 37 %	≥ 50 %	≥ 75 %	≥ 115 %	≥ 150 %	≥ 188 %
<input type="checkbox"/> XL	< 27 %	≥ 27 %	≥ 30 %	≥ 35 %	≥ 38 %	≥ 55 %	≥ 80 %	≥ 123 %	≥ 160 %	≥ 200 %
<input type="checkbox"/> XXL	< 28 %	≥ 28 %	≥ 32 %	≥ 36 %	≥ 40 %	≥ 60 %	≥ 85 %	≥ 131 %	≥ 170 %	≥ 213 %

Water heating energy efficiency class in colder and hotter climate conditions

Colder: <sup>3</sup> - 0.2 x <sup>2</sup> =  %

Hotter: <sup>3</sup> + 0.4 x <sup>2</sup> =  %

The energy efficiency of the set of products indicated in this sheet may not reflect the actual energy efficiency after installation since such efficiency is affected by additional factors, such as the heat loss in the distribution system and the size of the products compared to the size and features of the building.



**Parameters for filling in the DHW package fiche.**

Parametro	Rapax 200 V3	Rapax 200 Sol V3	Rapax 300 V3	Rapax 300 Sol V3
'I'	117	116	127	124
'II'	*	*	*	*
'III'	*	*	*	*

\* to be determined according to Regulation 812/2013 and transient calculation methods as per Notice of the European Community no. 207/2014.

27

**Domestic hot water production system package fiche.**

Water heating energy efficiency of the water heater

%

Stated load profile:

Solar contribution

From the board of the solar device

Auxiliary electricity

$(1.1 \times \text{_____} - 10\%) \times \text{_____} = \text{_____} + \text{_____} \%$

Water heating energy efficiency of the assembly in average climate conditions

%

Water heating energy efficiency class of the assembly in average climate conditions

	<input type="checkbox"/>	<input type="checkbox"/>	<input type="checkbox"/>	<input type="checkbox"/>	<input type="checkbox"/>	<input type="checkbox"/>	<input type="checkbox"/>	<input type="checkbox"/>	<input type="checkbox"/>	<input type="checkbox"/>
	G	F	E	D	C	B	A	A <sup>+</sup>	A <sup>++</sup>	A <sup>+++</sup>
<input type="checkbox"/> M	< 27 %	≥ 27 %	≥ 30 %	≥ 33 %	≥ 36 %	≥ 39 %	≥ 65 %	≥ 100 %	≥ 130 %	≥ 163 %
<input type="checkbox"/> L	< 27 %	≥ 27 %	≥ 30 %	≥ 34 %	≥ 37 %	≥ 50 %	≥ 75 %	≥ 115 %	≥ 150 %	≥ 188 %
<input type="checkbox"/> XL	< 27 %	≥ 27 %	≥ 30 %	≥ 35 %	≥ 38 %	≥ 55 %	≥ 80 %	≥ 123 %	≥ 160 %	≥ 200 %
<input type="checkbox"/> XXL	< 28 %	≥ 28 %	≥ 32 %	≥ 36 %	≥ 40 %	≥ 60 %	≥ 85 %	≥ 131 %	≥ 170 %	≥ 213 %

Water heating energy efficiency class in colder and hotter climate conditions

Colder:  $\text{_____} - 0.2 \times \text{_____} = \text{_____} \%$

Hotter:  $\text{_____} + 0.4 \times \text{_____} = \text{_____} \%$

*The energy efficiency of the set of products indicated in this sheet may not reflect the actual energy efficiency after installation since such efficiency is affected by additional factors, such as the heat loss in the distribution system and the size of the products compared to the size and features of the building.*

28





