



Instructions and recommendations

Installer



User

Maintenance technician

MAGIS HERCULES PRO 4-6-9

Heat pump comprising:
- indoor unit
UIMHP BP
- outdoor unit
AUDAX PRO 4-6-9 V2

1.045472ENG



INDEX

Dear Customer.....	4
General Recommendations.....	5
Safety symbols used.....	6
Personal protective equipment.....	6
1 Installing the Indoor Unit.....	7
1.1 Description of the product.....	7
1.2 Installation warnings.....	7
1.3 Indoor Unit main dimensions.....	10
1.4 Minimum indoor unit installation distances.....	11
1.5 Indoor unit hydraulic connection.....	12
1.6 Connecting the chiller line.....	12
1.7 Electrical connection.....	13
1.8 Remote zone control (Optional).....	19
1.9 MODBUS temperature and humidity room probes (Optional).....	20
1.10 Room chrono-thermostats (Optional).....	21
1.11 Humidistat ON/OFF (Optional).....	22
1.12 External temperature probe (Optional).....	22
1.13 Dominus (Optional).....	23
1.14 Dehumidifiers (optional).....	23
1.15 Temperature control setting.....	24
1.16 System filling.....	25
1.17 Operating limits.....	25
1.18 Indoor Unit start-up (ignition).....	26
1.19 Circulation pump.....	26
1.20 Domestic hot water storage tank unit.....	33
1.21 Kits available on request.....	34
1.22 Main components.....	35
2 Instructions for use and maintenance.....	36
2.1 General recommendations.....	36
2.2 Cleaning and maintenance.....	37
2.3 Control panel.....	37
2.4 System use.....	38
2.5 Operating mode.....	40
2.6 Parameters and information menu.....	46
2.7 Fault and anomaly signals.....	60
2.8 Restore central heating system pressure.....	70
2.9 Draining the system.....	70
2.10 Emptying the D.H.W. circuit.....	70
2.11 Storage tank draining.....	71
2.12 Cleaning the case.....	71
2.13 Permanent shutdown.....	71
3 Instructions for maintenance and initial check.....	72
3.1 General recommendations.....	72
3.2 Initial check.....	73
3.3 Yearly appliance check and maintenance.....	73
3.4 Finned air coil maintenance.....	74
3.5 Hydraulic diagram.....	75
3.6 Wiring diagram.....	77
3.7 System filter.....	87
3.8 Troubleshooting.....	87
3.9 P.C.B. programming.....	88
3.10 First ignition parameter setting.....	100
3.11 DHW (Domestic hot water) BOOST.....	102
3.12 Anti-legionella.....	102
3.13 DHW (Domestic hot water) recirculation.....	102
3.14 Pump anti-block.....	103

3.15	Three-way anti-block	103
3.16	System setpoint correction	103
3.17	Photovoltaic	103
3.18	Integration with system internal electrical resistance	104
3.19	Integration with system external electrical resistances	105
3.20	Zone 2/3 safety thermostat	105
3.21	Conjunction Mode	106
3.22	Heat pump disabling function	106
3.23	Power reduction function	106
3.24	Diverter valve management (summer / winter)	106
3.25	External probe setting	107
3.26	Manual drives	107
3.27	Outdoor unit Testmode Function	107
3.28	Outdoor Unit Pump Down	107
3.29	Supervision device configuration	107
3.30	Dehumidification BOOST function	108
3.31	Dehumidification function	108
3.32	Casing removal	109
3.33	Indoor unit separation	116
4	Technical data	120
4.1	Technical data table	120
4.2	Key for data nameplate	122
4.3	Magis Hercules Pro 4 product fiche (in compliance with Regulation 811/2013)	123
4.4	Table 2 Regulation 813/2013	124
4.5	Magis Hercules Pro 6 product fiche (in compliance with Regulation 811/2013)	125
4.6	Table 2 Regulation 813/2013	126
4.7	Magis Hercules Pro 9 product fiche (in compliance with Regulation 811/2013)	127
4.8	Table 2 Regulation 813/2013	128
4.9	Parameters for filling in the package fiche	129

Dear Customer

Congratulations for having chosen a top-quality Immergas product, able to assure well-being and safety for a long period of time. As an Immergas customer you can also count on a Qualified Authorised After-Sales Technical Assistance Centre, prepared and updated to guarantee constant efficiency of your appliance. Read the following pages carefully: you will be able to draw useful tips on the proper use of the device, compliance with which will confirm your satisfaction with the Immergas product.

For assistance and routine maintenance, contact Authorised Technical Service Centres: they have original spare parts and are specifically trained directly by the manufacturer.

Thermal systems must undergo periodic maintenance and scheduled checks of the energy efficiency in compliance with national, regional or local provisions in force.

The company **IMMERGAS S.p.A.**, with registered office in via Cisa Ligure 95 42041 Brescello (RE), declares that the design, manufacturing and after-sales assistance processes comply with the requirements of standard **UNI EN ISO 9001:2015**.

For further details on the product CE marking, request a copy of the Declaration of Conformity from the manufacturer, specifying the appliance model and the language of the country.

The manufacturer declines all liability due to printing or transcription errors, reserving the right to make any modifications to its technical and commercial documents without forewarning.



GENERAL RECOMMENDATIONS

This book contains important information for the:

Installer (section 1);

User (section 2);

Maintenance Technician (section 3).

- The user must carefully read the instructions in the specific section (section 2).
 - The user must limit operations on the appliance only to those explicitly allowed in the specific section.
 - The appliance must be installed by qualified and professionally trained personnel.
 - It must be stored with care and consulted carefully, as all of the warnings provide important safety indications for installation, use and maintenance stages.
 - In compliance with the legislation in force, the systems must be designed by qualified professionals, within the dimensional limits established by the Law. Installation and maintenance must be performed in compliance with the regulations in force, according to the manufacturer's instructions and by professionally qualified staff, meaning staff with specific technical skills in the plant sector, as provided for by Law.
 - Improper installation or assembly of the Immergas device and/or components, accessories, kits and devices can cause unexpected problems for people, animals and objects. Read the instructions provided with the product carefully to ensure proper installation.
 - This instructions manual provides technical information for installing Immergas products. As for the other issues related to the installation of products (e.g. safety at the workplace, environmental protection, accident prevention), it is necessary to comply with the provisions of the standards in force and the principles of good practice.
 - All Immergas products are protected with suitable transport packaging.
 - The material must be stored in a dry place protected from the weather.
 - Damaged products must not be installed.
 - Maintenance must be carried out by skilled technical staff. For example, the Authorised Service Centre that represents a guarantee of qualifications and professionalism.
 - The appliance must only be destined for the use for which it has been expressly declared. Any other use will be considered improper and therefore potentially dangerous.
 - If errors occur during installation, operation and maintenance, due to non-compliance with technical laws in force, standards or instructions contained in this booklet (or however supplied by the manufacturer), the manufacturer is excluded from any contractual and extra-contractual liability for any damages and the device warranty is invalidated.
 - In the event of malfunctions, faults or incorrect operation, turn the appliance off and contact an authorised company (e.g. the Authorised Technical Assistance Centre, which has specifically trained staff and original spare parts). Do not attempt to modify or repair the appliance alone.
-

SAFETY SYMBOLS USED



GENERIC HAZARD

Strictly follow all of the indications next to the pictogram. Failure to follow the indications can generate hazard situations resulting in possible harm to the health of the operator and user in general, and/or property damage.



ELECTRICAL HAZARD

Strictly follow all of the indications next to the pictogram. The symbol indicates the appliance's electrical components or, in this manual, identifies actions that can cause an electrical hazard.



WARNING FOR INSTALLER

Read the instruction booklet carefully before installing the product.



LOW FLAMMABILITY MATERIAL

The symbol indicates that the appliance contains low flammability material.



WARNINGS

Strictly follow all of the indications next to the pictogram. Failure to follow the indications can generate hazard situations resulting in possible minor injuries to the health of both the operator and the user in general, and/or slight material damage.



ATTENTION

Read and understand the instructions of the appliance before carrying out any operation, carefully following the instructions given. Failure to observe the instructions may result in malfunction of the unit.



INFORMATION

Indicates useful tips or additional information.



EARTH TERMINAL CONNECTION

The symbol identifies the appliance's earth terminal connection point.



DISPOSAL WARNING

The user must not dispose of the appliance at the end of its service life as municipal waste, but send it to appropriate collection centres.

PERSONAL PROTECTIVE EQUIPMENT



SAFETY GLOVES



EYE PROTECTION



SAFETY FOOTWEAR

1 INSTALLING THE INDOOR UNIT

1.1 DESCRIPTION OF THE PRODUCT.

Magis Hercules Pro 4-6-9 is a heat pump consisting of:

- UIMHP BP indoor unit (hereinafter called, indoor unit or UIMHP).
- Audax Pro 4-6-9 V2 outdoor condensing unit (hereinafter referred to as outdoor condensing unit or Audax Pro 4-6-9 V2).

Magis Hercules Pro 4-6-9 is perfectly operational only if the two units are correctly powered and interconnected.

The UIMHP indoor unit was designed solely for floor installation for heating and air conditioning and to produce domestic hot water for domestic use and similar purposes.

For normal operation it must be paired with one of the following outdoor units:

- Audax Pro 4 V2;
- Audax Pro 6 V2;
- Audax Pro 9 V2.

Accordingly, it is necessary to comply with all of the rules regarding safety and the use of both appliances.

1.2 INSTALLATION WARNINGS



Operators who install and service the appliance must wear the personal protective equipment required by applicable law.



The place of installation of the appliance and relative Immergas accessories must have suitable features (technical and structural), such as to allow for (always in safe, efficient and comfortable conditions):

- installation (according to the provisions of technical legislation and technical regulations);
- maintenance operations (including scheduled, periodic, routine and special maintenance);
- removal (to outdoors in the place for loading and transporting the appliances and components) as well as the eventual replacement of those with appliances and/or equivalent components.



Installation must be carried out according to regulation standards, current legislation and in compliance with local technical regulations and the required technical procedures.



**The appliance operates with R32 refrigerant gas.
This gas is ODOURLESS.**

Pay the utmost attention

Strictly follow the instruction handbook of the Outdoor Unit before installation and any type of operation on the chiller line.



R32 refrigerant gas belongs to the low flammability refrigerant category: class A2L according to standard ISO 817. It guarantees high performance with low environmental impact. The new gas reduces the potential environmental impact by one third compared to R410A, having less effect on global warming (GWP 675).



The manufacturer declines all liability in the event of damage caused by appliances removed from other systems or for any non-conformities with such equipment.



Only a professionally enabled company is authorised to install Immergas appliances.



Check the environmental operating conditions of all parts relevant to installation, referring to this booklet.



If installing a kit or servicing the appliance, always empty the system's domestic hot water circuit first so as not to compromise the appliance's electrical safety (Par. 2.9, 2.10).

Always disconnect the appliance from voltage and, depending on the type of operation, decrease the pressure and/or bring it to zero in the gas and DHW circuits.



Before installing the appliance, ensure that it is delivered in perfect condition; if in doubt, contact the supplier immediately. Packing materials (staples, nails, plastic bags, polystyrene foam, etc.) constitute a hazard and must be kept out of the reach of children.

If the appliance is installed inside or between cabinets, ensure sufficient space for routine servicing; for minimum installation distances, see Fig. 3.



Keep all combustible material away from the appliance (paper, rags, plastic, polystyrene, etc.).



Any modification to the appliance that is not explicitly indicated in this section of the booklet is forbidden.

Installation standards



This appliance must be installed in an environment where the temperature cannot fall below 0°C. Do not expose the indoor unit to atmospheric agents.



This type of installation is possible when permitted by the laws in force in the appliance's country of destination.



Do not install in places/rooms that constitute public areas of apartment buildings, internal stairways or other escape routes (e.g. floor landings, entrance halls, etc.).



To prevent electrocution, fire or injury, always switch off the unit, disable the protective switch and, if smoke escapes or if the unit is extremely noisy, contact the Authorised After-Sales Technical Assistance Centre.



Do not install in places where there is the risk of combustible gas escaping.



Do not install near sources of heat.



Pay attention not to generate sparks as follows:

- Do not remove the fuses while the unit is on.
- Do not unplug the unit while it is on.

It is recommended to install the outlet high up. Lay the cables in such a way that they do not get tangled.



This Indoor Unit is used to heat water to below boiling temperature in atmospheric pressure.



They must be connected to a central heating system and domestic hot water circuit suited to their performance and capacity.



The appliance is built to also operate in cooling mode.
If cold water production, during summer, could interfere and damage the central heating only systems, necessary precautions must be taken to prevent that an unintentional production of cold water enters the heating only system.



Failure to comply with the above implies personal responsibility and invalidates the warranty.

“Anti-legionella” thermal treatment of the accumulation storage tank.



The anti-Legionella function is programmed directly on the control panel.

During this phase, the temperature of the water inside the tank exceeds 60°C with the subsequent risk of burns. Keep this domestic hot water treatment under control (and inform the users) to prevent unforeseeable damage to people, animals, things. If required install a thermostatic valve on the domestic hot water outlet to prevent scalding.

Data nameplate positioning

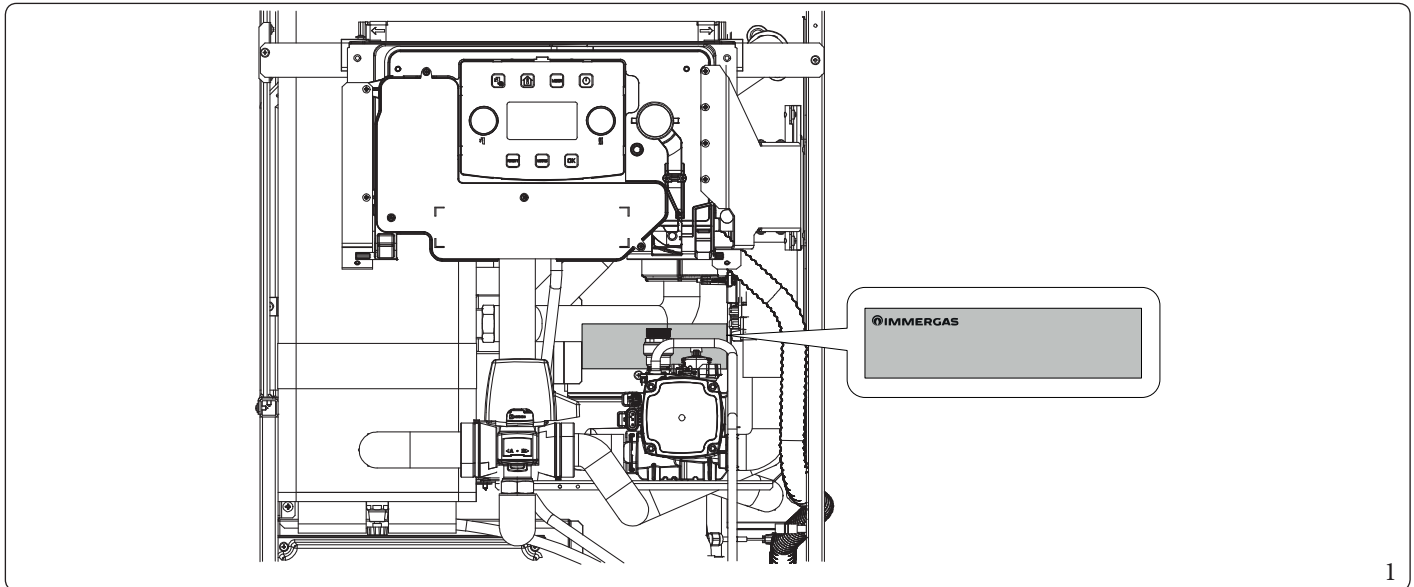

1.3 INDOOR UNIT MAIN DIMENSIONS

INSTALLER

USER

MAINTENANCE TECHNICIAN

TECHNICAL DATA

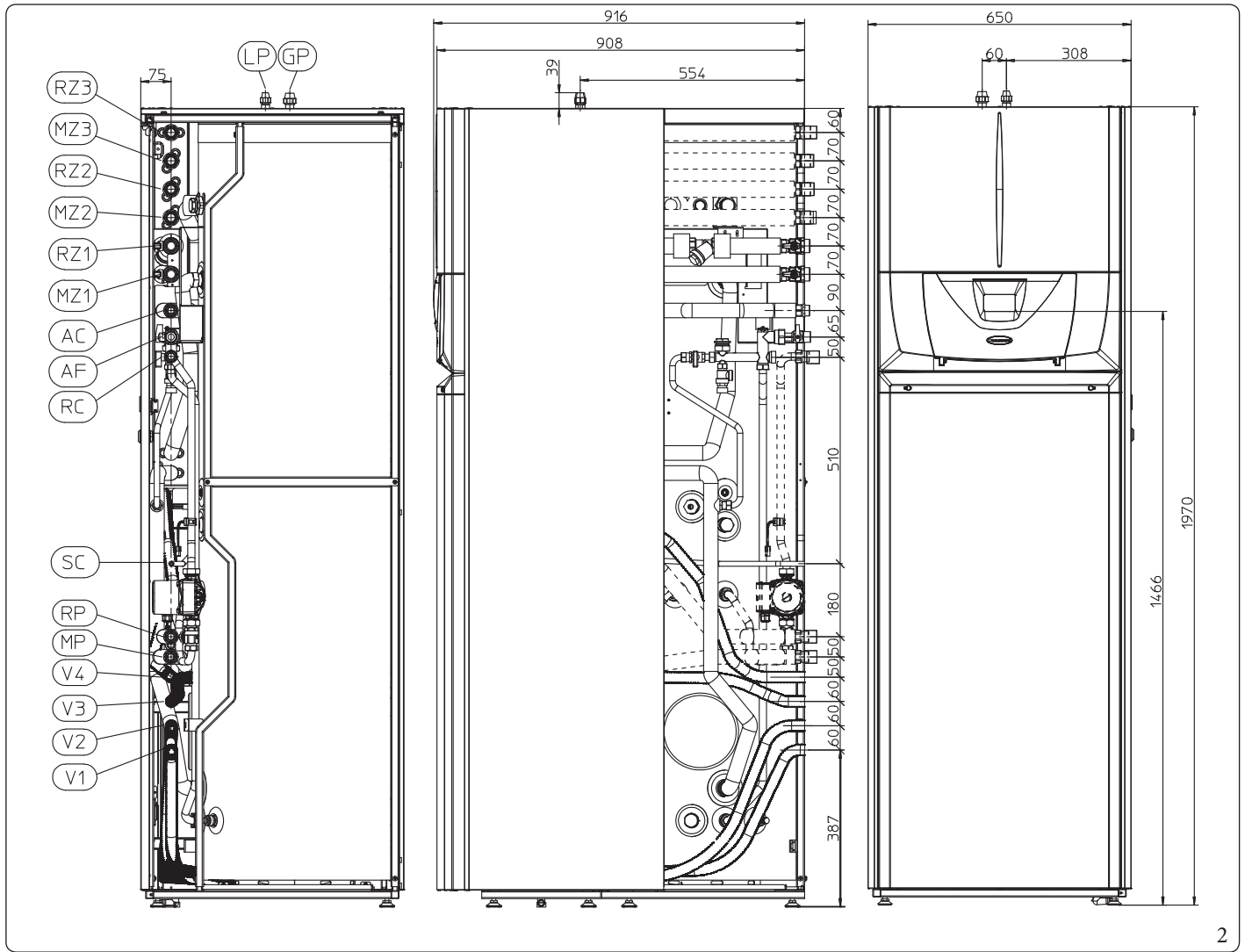

2

Key (Fig. 2):

- RP - Return to solar panels (optional)
- MP - Flow from solar panels (optional)
- RZ3 - Mixed zone 3 system return (optional)
- MZ3 - Mixed zone 3 system flow (optional)
- RZ2 - Mixed zone 2 system return (optional)
- MZ2 - Mixed zone 2 system flow (optional)
- RZ1 - Direct zone 1 system return
- MZ1 - Direct zone 1 system flow
- AC - Domestic hot water outlet
- AF - DHW (Domestic hot water) water inlet
- RC - Pump (optional)
- SC - Discharge any condensate collected in the tray
- LP - Chiller line - liquid phase
- GP - Chiller line - gaseous phase
- V1 - 3rd zone electrical connections
- V2 - Additional resistance power supply electrical connections
- V3 - Power supply cable electrical connections
- V4 - Main electrical connections

Height (mm)		Width (mm)		Depth (mm)			
1970		650		916			
CONNECTIONS							
CHILLER LINE		D.H.W.	RECIRCULATION	SYSTEM			
LP	GP	AC - AF	RC	RP - MP	RZ1 - MZ1	RZ2 - MZ2	RZ3 - MZ3
SAE 1/4"	SAE 5/8"	G 3/4"	G 3/4"	G 3/4"	G 1"	G 1"	G 1"

1.4 MINIMUM INDOOR UNIT INSTALLATION DISTANCES

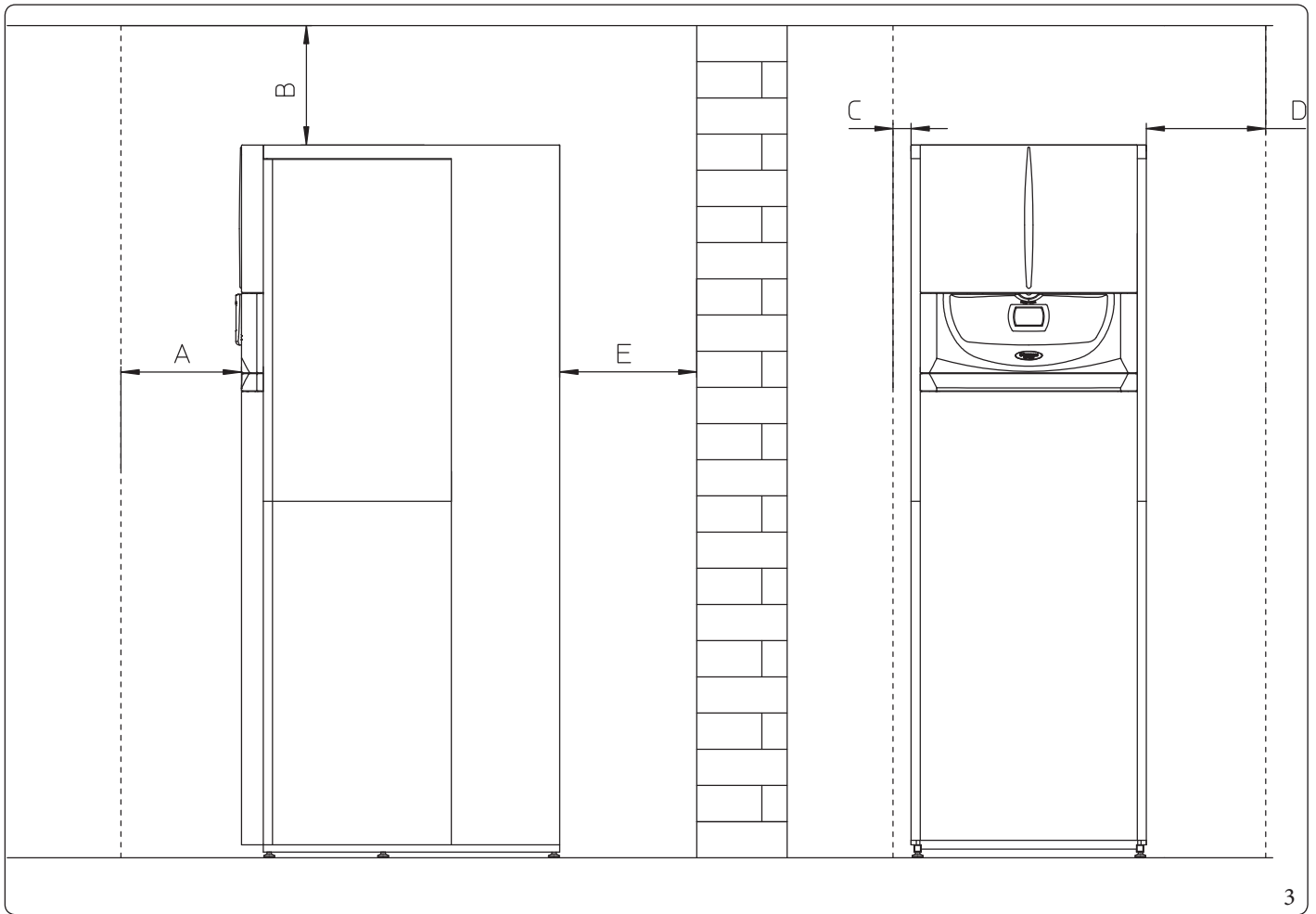

Key (Fig. 3):

- A - 500 mm
- B - 200 mm
- C - 30 mm
- D - 400 mm
- E - 10 mm

INSTALLER

USER

MAINTENANCE TECHNICIAN

TECHNICAL DATA

1.5 INDOOR UNIT HYDRAULIC CONNECTION

3 and 8 bars safety valve



The appliance safety valves outlet must be connected to a tundish.
Otherwise, the appliance's manufacturer declines any responsibility in case of flooding if the drain valves cut.

A treatment of the heating and water system water is required, in compliance with the technical standards in force, in order to protect the system and the appliance from deposits (e.g. scale), slurry or other hazardous deposits.

Water connections must be made in a rational way using the couplings on the Indoor Unit template.



The manufacturer declines all liability in the event of damage caused by the installation of an automatic filling system.

In order to meet the system requirements established by EN 1717 in terms of pollution of drinking water, we recommend installing the IMMERGAS anti-backflow kit to be used upstream of the cold water inlet connection of the Indoor Unit. We also recommend using category 2 heat transfer fluid (ex: water + glycol) in the Indoor Unit primary circuit (heating and/or cooling circuit), as defined in standard EN 1717.



To preserve the duration of appliance efficiency features, in the presence of water whose features can lead to the deposit of lime scale, installation of the "polyphosphate dispenser" kit is recommended.

1.6 CONNECTING THE CHILLER LINE

As far as connecting the chiller line is concerned, all the instructions contained in the outdoor unit instructions booklet must be followed.

Make the connections directly on the indoor unit couplings.

1.7 ELECTRICAL CONNECTION

Indoor unit electrical connection

The internal unit has an IPX5D degree of protection; electrical safety of the appliance is achieved only when it is properly connected to an efficient earthing system, as specified by current safety standards.



The manufacturer declines any responsibility for damage or physical injury caused by failure to connect the Indoor Unit to an efficient earthing system or failure to comply with the IEC reference standards.

Connections are provided to both the control panel (Fig. 7) and the main panel (Fig. 8).

Main panel opening (Fig. 4).

To open the main panel, simply follow the instructions below:

1. Remove the aesthetic profile.
2. Disassemble the lower front.
3. Loosen the screws (a)
4. Remove the main panel cover (b).

Ensure that the electrical installation corresponds to maximum absorbed power specifications as shown on the indoor unit data name-plate.

Indoor units are supplied complete with an “X” type power cable (c) without plug.



The power supply cable must be connected to a 230V \pm 10% / 50Hz mains supply respecting L-N polarity and earth connection; this network must also have a multi-pole circuit breaker with class III overvoltage category in compliance with installation regulations.



To protect from possible dispersions of DC voltage, it is necessary to provide a type A differential safety device.



If the power supply cable is damaged, it must be replaced by a special cable or assembly, which are only available from the manufacturer or its Authorised After-Sales Technical Assistance Centre.

It is recommended to contact a qualified company (e.g. the Authorised After-Sales Technical Assistance Centre) for replacement to avoid a hazard.

The power supply cable must be laid as shown (Fig. 4).

If the fuses on the circuit boards need to be replaced, this must also be done by qualified personnel.

The appliance is equipped with two fuses: one 3.15A rapid 230 V fuse and one 10 A rapid 230 V fuse for integrative resistance.

For the main power supply to the appliance, never use adapters, multiple sockets or extension leads.

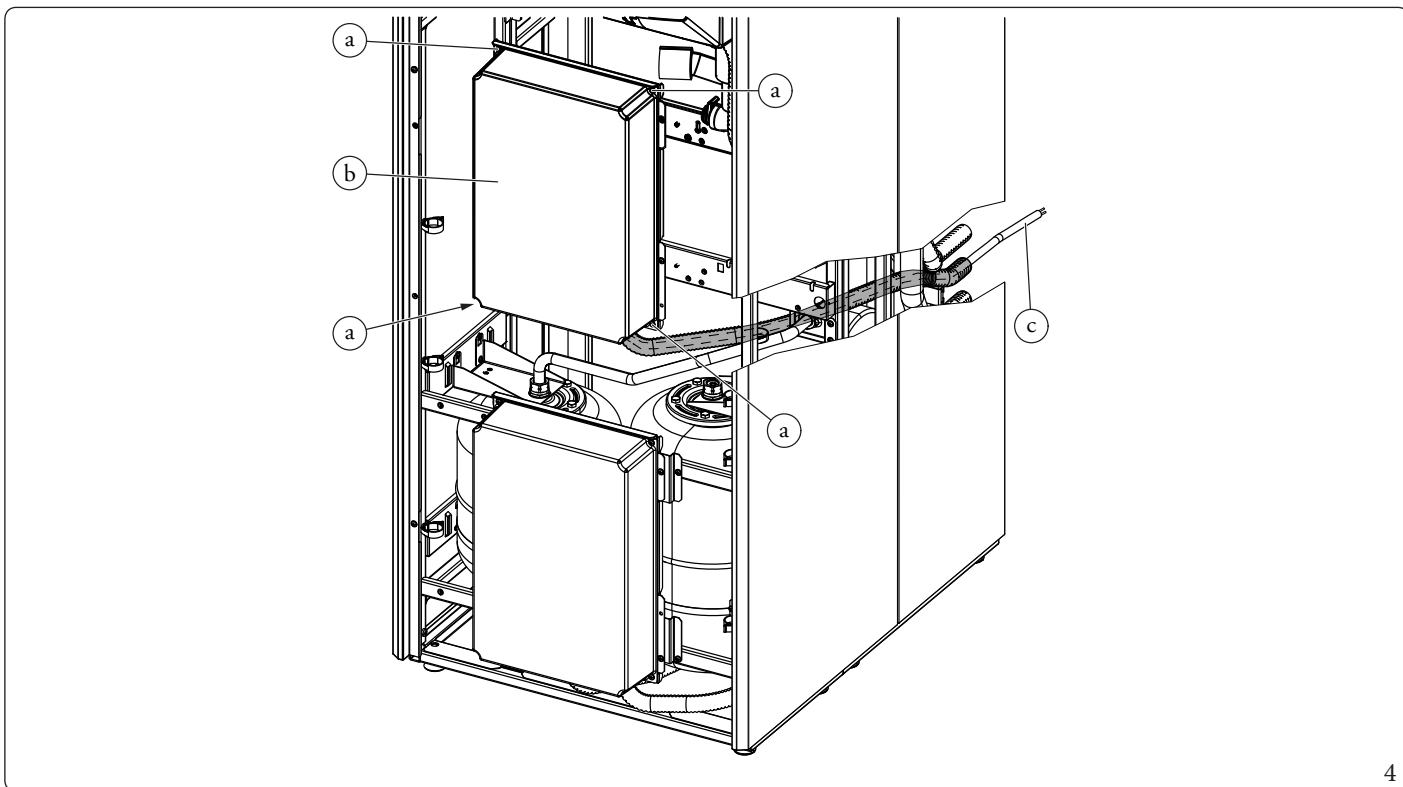

Electrical connections to the main panel

The electrical connections available are:

- Zone 1 flow probe;
- Zone 2 flow probe;
- Dehumidifier Zone 2;
- Zone 2 humidistat;
- Zone 2 thermostat;
- DHW recirculation probe;
- Optional DHW (Domestic hot water) integrative resistances;
- Optional system integrative resistances;
- Recirculation pump;
- Zone 2 pump;
- Zone 2 Mixing Valve;
- Zone 2 dehumidifier alarm input.

The connection cables must follow the predetermined path using the special cable glands (a) (Fig. 5).

Key (Fig. 5):

- 1 - Three-way connection (M30)
- 2 - Pump connection (M1)
- 3 - Return probe connection (B5)
- 4 - Flow probe connection (B1)
- 5 - Liquid phase probe (B29)
- 6 - Zone 1 pump connection (M10-1)
- 7 - Flow meter connection (B25)
- 8 - DHW probe connection (B2)
- 9 - DHW (Domestic hot water) resistance connection (E15-A)
- a - Cable gland

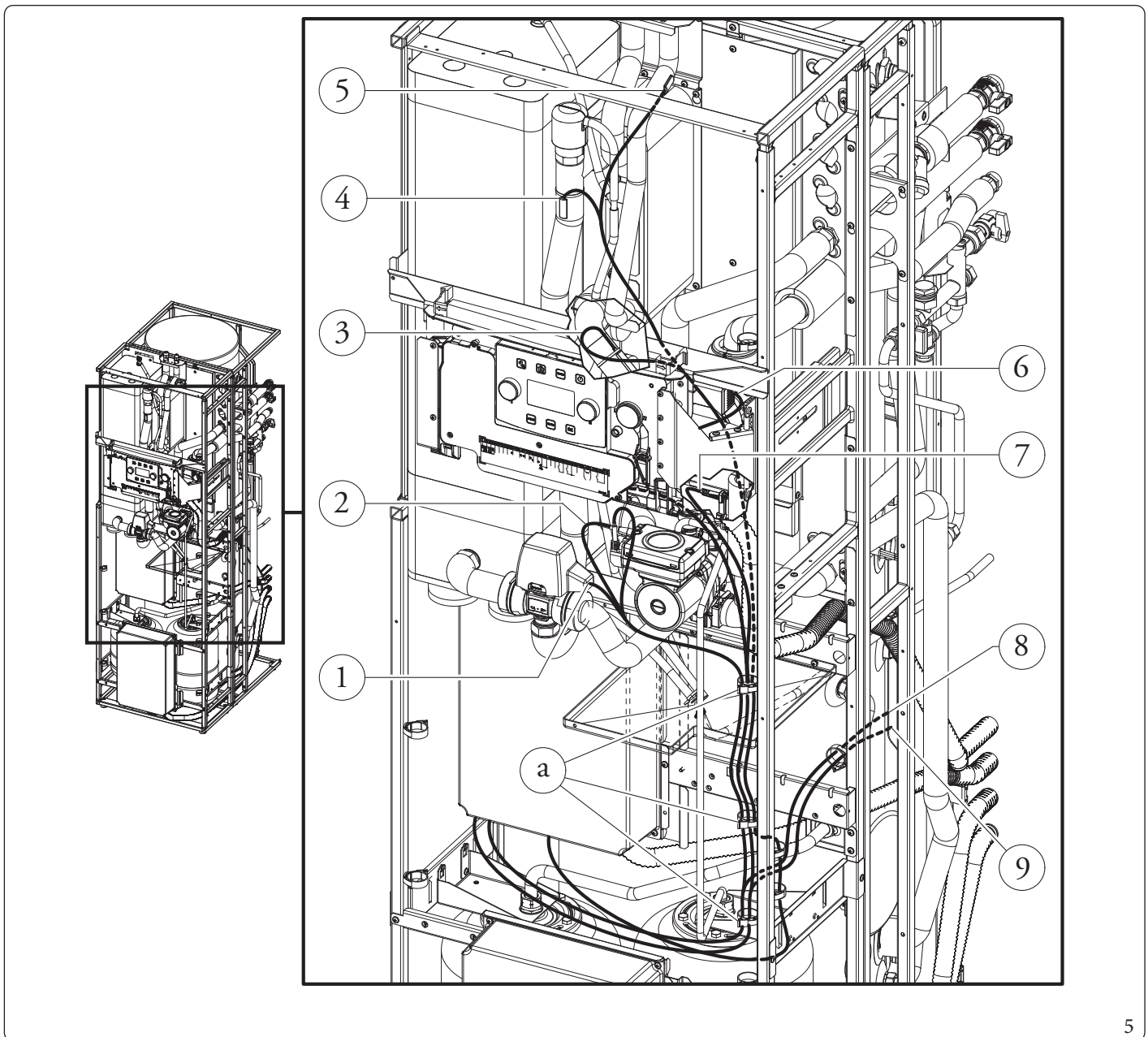

INSTALLER

USER

MAINTENANCE TECHNICIAN

TECHNICAL DATA

5

Open the control panel connections compartment (Fig. 6).

To carry out electrical connections, all you have to do is open the connections compartment as follows.

1. Remove the cover and the aesthetic profile.
2. Disassemble the cover.
3. Loosen the screws (a).
4. Remove the cover (b) from the control panel (c).

At this point, you can access the terminal board.

Electrical connections to the control panel

The electrical connections available are:

- Photovoltaic system: connecting the product to a photovoltaic system enhances use of the outdoor unit when the photovoltaic panels are operating.
- Dehumidifier zone 1.
- Zone 1 dehumidifier alarm input.
- Summer/winter diverter.
- Multifunction relay.
- Zone 1 humidistat and thermostat.
- Zone 1, 2, 3 remote devices (Zone remote panel, Temperature/humidity probe, Dominus).
- External probe
- Heat pump disabling.

Make the various electrical connections according to your needs (Fig. 7).

Outdoor unit electrical connection

The indoor unit must be coupled to an outdoor unit by connecting terminals F1 and F2 as shown in the wiring diagram (Fig.7). The outdoor unit is powered at 230 V, regardless of the indoor unit.

Configure the parameter "HP Model" as indicated in the paragraph (Par. 3.9) according to the type of connected outdoor unit.

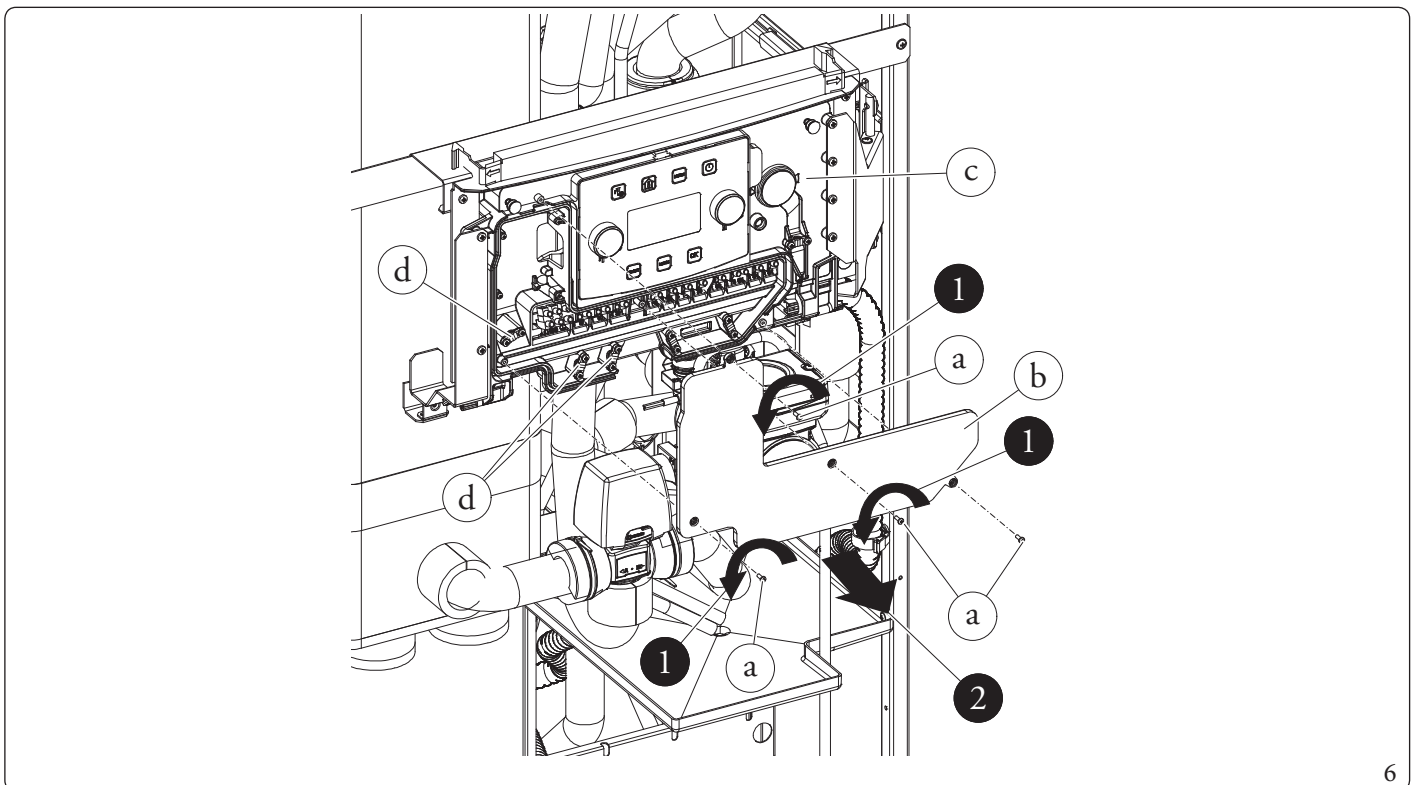

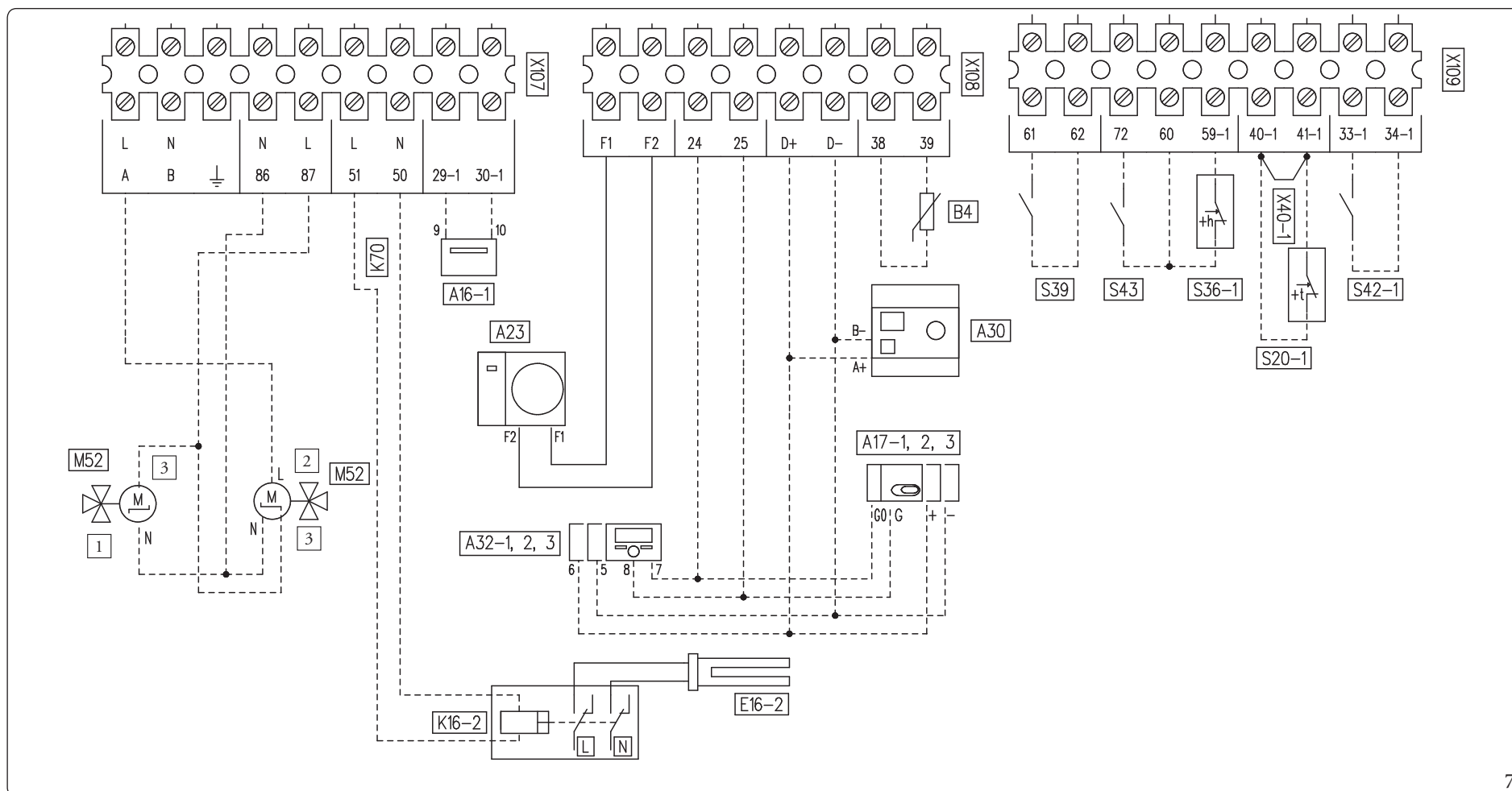

Key (Fig. 7):

- | | | | |
|-----------|--|-------|--|
| A16-1 | - Zone 1 dehumidifier (optional) | S20-1 | - Zone 1 room thermostat (optional) |
| A17-1,2,3 | - Zone 1, 2, 3 temperature/humidity probe (optional) | S36-1 | - Zone 1 humidistat (optional) |
| A23 | - Outdoor unit | S39 | - Photovoltaic inlet (optional) |
| A32-1,2,3 | - Zone 1, 2, 3 remote panel (optional) | S42-1 | - Zone 1 dehumidifier alarm (optional) |
| A30 | - Dominus (optional) | S43 | - Pdc disabling selector (optional) |
| B4 | - External probe | X40-1 | - Zone 1 room thermostat link |
| E16-2 | - Zone 2 external system integrative resistance (optional) | 1 | - Valve with spring return |
| K16-2 | - System integrative resistance relay (optional) | 2 | - 2-point valve |
| K70 | - Multifunction relay (optional) | 3 | - Open/Closed |
| M52 | - Summer/winter diverter (optional) | | |

TECHNICAL DATA

MAINTENANCE TECHNICIAN

USER

INSTALLER

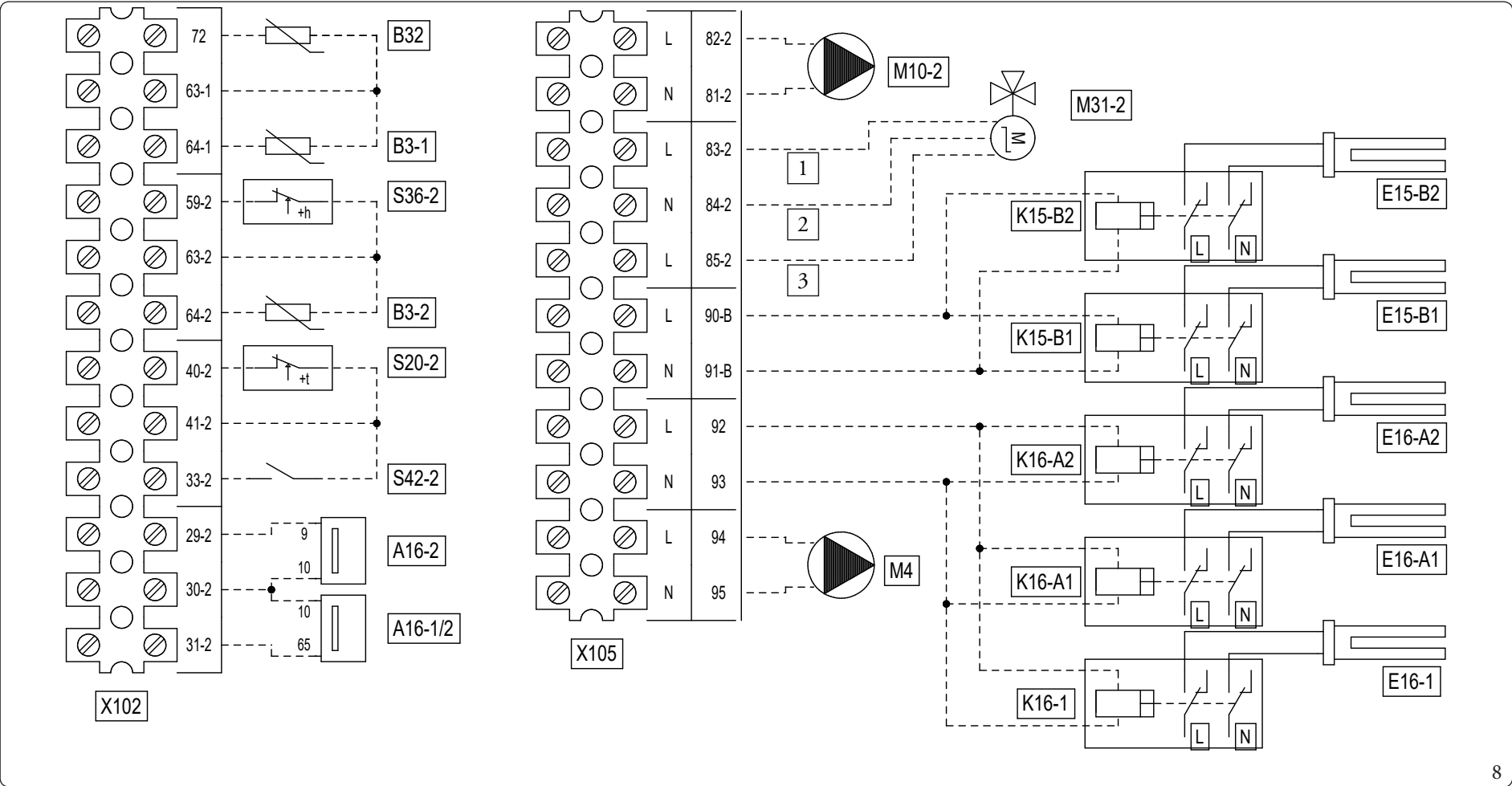

Key (Fig. 8):

- A16-1/2 - Zone 1 or zone 2 dehumidifier (optional)
- A16-2 - Zone 2 dehumidifier (optional)
- B3-1 - Zone 1 flow probe (optional)
- B3-2 - Zone 2 flow probe (optional)
- B32 - Recirculation Probe
- E15-B1, -B2 - Secondary DHW integration resistance (optional)
- E16-A1, -A2 - Internal system integrative resistance (optional)
- E16-1 - Zone 1 external system integrative resistance (optional)
- K15-B1, B2 - Secondary DHW integration resistance relay (optional)
- K16-A1, A2 - System integrative resistance relay (optional)

- K16-1 - System integrative resistance relay (optional)
- M4 - DHW recirculation pump (optional)
- M10-2 - Zone 2 circulator pump (optional)
- M31-2 - Zone 2 mixing valve (optional)
- S20-2 - Zone 2 room thermostat (optional)
- S36-2 - Zone 2 humidistat (optional)
- S42-2 - Zone 2 dehumidifier alarm (optional)
- 1 - Closed
- 2 - Common
- 3 - Open

1.8 REMOTE ZONE CONTROL (OPTIONAL)

This remote device is used to adjust the setpoints and to view the main information of the zone where it was configured.

Make the connection to the appliance as shown (Fig. 7) and leave the jumper on terminals 40-1/41-1 for zone 1 and terminals 40-2/41-2 for zone 2.

To correctly configure the device, set the parameters as described below:

Assistance Menu -> Device configuration	
Slave address: Address to configure according to the zone where the device is installed	Zone 1 = 41
	Zone 2 = 42
	Zone 3 = 43
Baud Rate	9600
Parity bit	Even
Stop bits	1
Heat pump control	NO

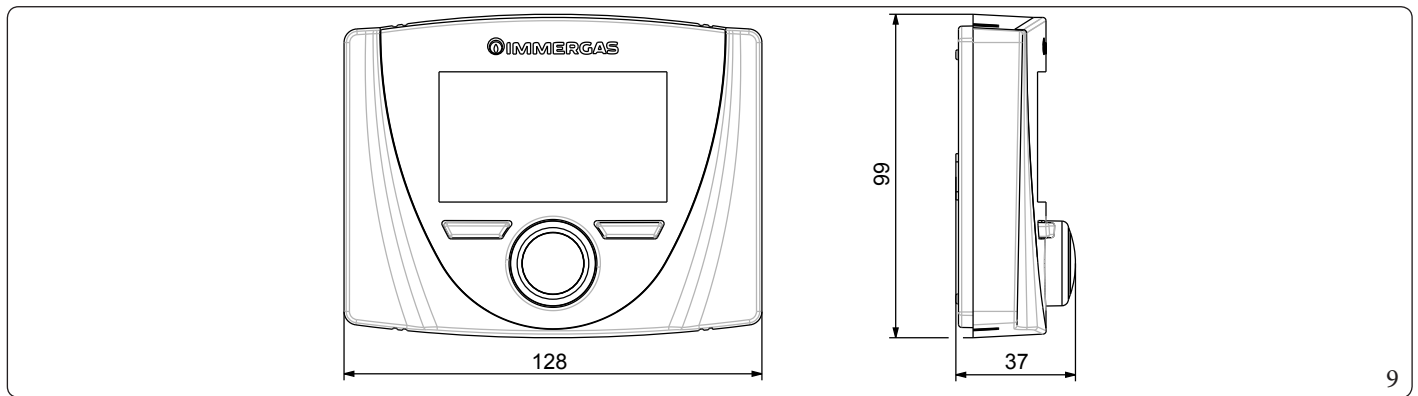

INSTALLER

USER

MAINTENANCE TECHNICIAN

TECHNICAL DATA

1.9 MODBUS TEMPERATURE AND HUMIDITY ROOM PROBES (OPTIONAL)

The Modbus temperature and humidity probe is used to detect the room temperature and humidity and to calculate the dew point. In addition, by setting the relative zone room setpoints available on the Control panel (see 2Par. 2.6), it is possible to check the temperature and humidity of a room.

Make the connection to the appliance as shown (Fig. 7) and set the DIP-switches on the probe.

DIP-Switch configuration table

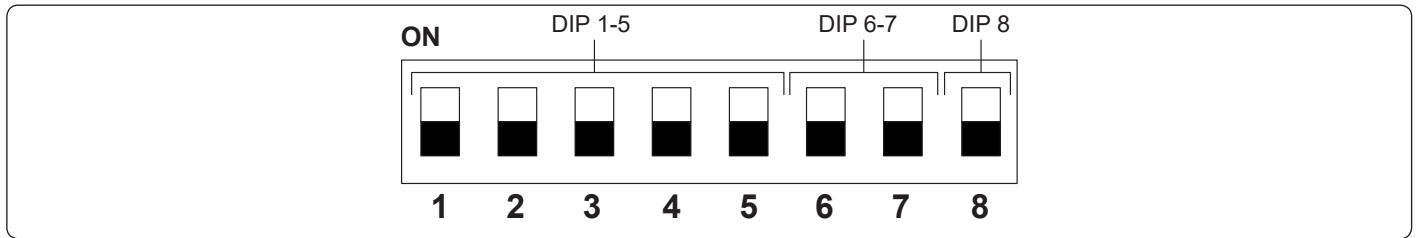

DIP 1-5 (Address)	<p>ON</p> <p>1 2 3 4 5</p>	Zone 1 (Address 131)
	<p>ON</p> <p>1 2 3 4 5</p>	Zone 2 (Address 132)
	<p>ON</p> <p>1 2 3 4 5</p>	Zone 3 (Address 133)

DIP 6-7 (Type)	<p>ON</p> <p>6 7</p>	Modbus 1-8-E-1
-------------------	----------------------	----------------

DIP 8 (Speed)	<p>8</p>	9600 bit/s
------------------	----------	------------

1.10 ROOM CHRONO-THERMOSTATS (OPTIONAL)

The Indoor Unit is prepared for the application of room chrono-thermostats, which are available as optional kits. A maximum of 3 temperature controllers can be applied directly to the appliance. All Immergas chrono-thermostats are connected with 2 wires only. Carefully read the user and assembly instructions contained in the accessory kit.



Disconnect power to the unit before making any electrical connections.

On/Off Immergas digital chrono-thermostat.

The chrono-thermostat allows:

- set two room temperature value: one for day (comfort temperature) and one for night (reduced temperature);
- set a weekly programme with four daily switch on and switch off times;
- selecting the required function mode from the various possible alternatives:
 - manual mode (with adjustable temperature);
 - automatic mode (with set programme);
 - forced automatic operation (momentarily changing the temperature of the automatic program).

The chrono-thermostat is powered by two 1.5V LR6 type alkaline batteries.

On/Off chrono-thermostat electrical connection (Optional).



The operations described below must be performed after having removed the voltage from the appliance.

On/Off ambient thermostat or chrono-thermostat: must be connected to the 40-1 / 41-1 terminals, eliminating the X40-1 jumper for zone 1 and 40-2 / 41-2 for zone 2 and 40-3 / 41-3 connected to the expansion kit for zone 3.

Make sure that the On/Off thermostat contact is of the “clean” type, i.e. independent of the mains voltage, otherwise the P.C.B. would be damaged.

The connections must be made on the terminal board inside the control panel (Fig. 7) or the appliance’s main panel (Fig. 8).



If any On/Off chrono-thermostat is used, arrange two separate lines in compliance with current regulations regarding electrical systems.

No indoor unit pipes must ever be used to earth the electric system or telephone lines.

Ensure elimination of this risk before making the indoor unit electrical connections.

1.11 HUMIDISTAT ON/OFF (OPTIONAL)

You can make a dehumidification demand by using a humidistat.

Make the connection to the appliance as shown (Fig. 7) and leave the jumper on terminals 40-1/41-1 for zone 1 and terminals 40-2/41-2 for zone 2.

1.12 EXTERNAL TEMPERATURE PROBE (OPTIONAL)

The outdoor unit has a standard external probe that can be used as an external probe of the heat pump.

The external probe is used to:

- Thermoregulate the water flow temperature;
- Determine the use of additional generators (electrical resistances).

If the Outdoor Unit is positioned in an area that is not suitable for temperature reading, it is advisable to use an additional external probe (Fig. 10) which is available as an optional kit.

Refer to the relative instruction sheet for positioning of the external probe.

For the proper operation of the optional probe, it must be electrically connected where envisaged (Fig.7) and then enabled (Par. 3.25)

The presence of the external probe allows the system flow temperature to be set automatically based on the outdoor temperature in order to adapt the heating or cooling provided to the system.

The system flow temperature is determined by the setting on the "Zones" menu and by the "User" menu for the offset values based on the curves shown in the diagram (Par. 1.15).



If the system is divided into two or three zones, the flow temperature is calculated based on the zone with the higher temperature in central heating mode and with the lower temperature in cooling mode.

In the event of a fault of the (optional) external probe, after switching it off and back on, the outside temperature is automatically detected by the external probe on the outdoor unit.

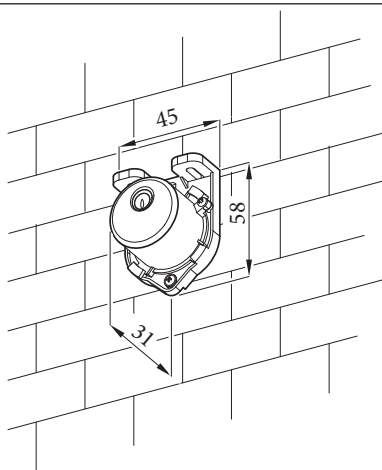

1.13 DOMINUS (OPTIONAL)

The system can be remote controlled using the optional Dominus kit.

Connect the appliance as shown (Fig. 8).

The following is necessary to enable Dominus:

- position the Dip Switches: OFF-OFF-OFF-ON;
- set the parameter on the control panel **System supervision = Domin**;
- configure the Dominus APP profile on Magis Hercules Pro.



The Dominus firmware must be updated to at least revision 2.02.

For further information, consult the relative instruction sheet.

1.14 DEHUMIDIFIERS (OPTIONAL)

To use the dehumidification function required during the cooling function in the radiant systems, it is possible to install dehumidifiers and control them directly from the management board.

Connect as shown in fig. 7 and 8.

With the installation of a Immergas dehumidifier, it is possible to activate either the dehumidification function in neutral air or in cooled air (see dehumidifier kit manual for more details on the function).

In this case the dehumidification function on cooled air must be selected exclusively either on zone 1 or only on zone 2 with parameter **Special parameters / Dehumid. in cool.air** by selecting the corresponding zone where you wish to activate this function and by connecting clamps 65 and 10 of the relative dehumidifier respectively to terminals 31-2 and 30-2 of terminal block X102 (Fig. 8).

1.15 TEMPERATURE CONTROL SETTING

By setting the parameters in the menus

Zones/Configuration

it is possible to automatically adjust the flow temperature of each zone according to the outdoor temperature. This can be done by enabling the external probe modulation in the menu

Zones/Enablings

The curves (Fig. 11, 12, 13, 14) show the default settings in the various operating modes available both with external probe and without.

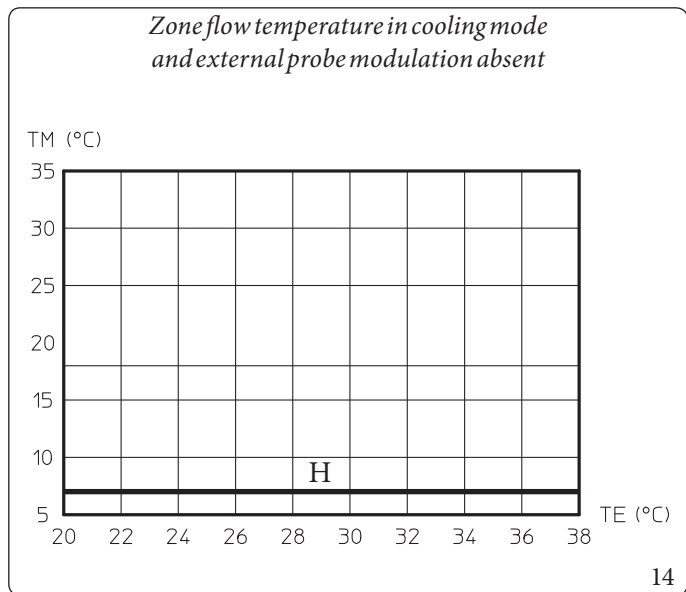
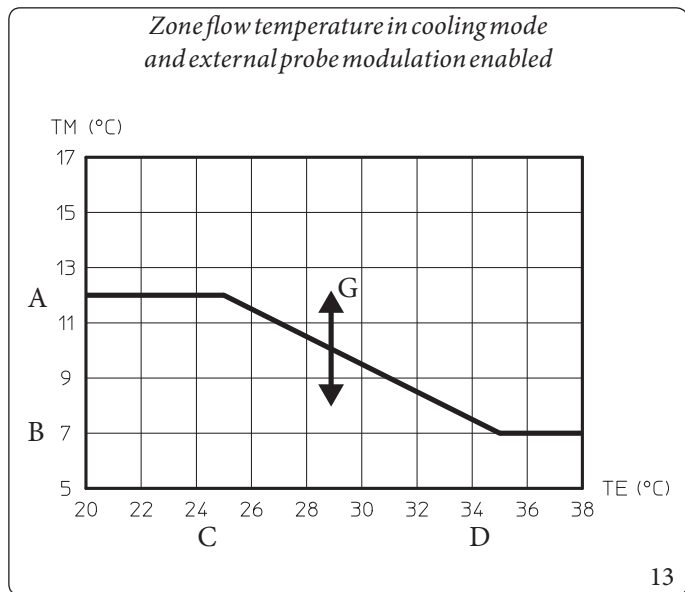
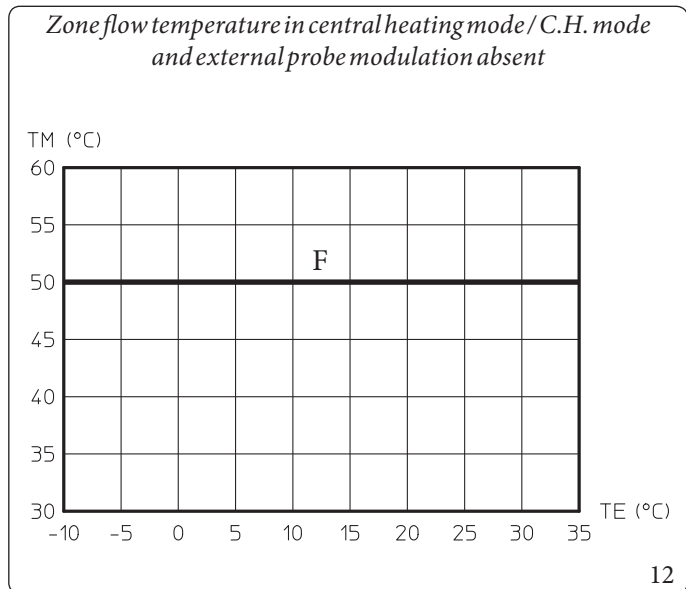
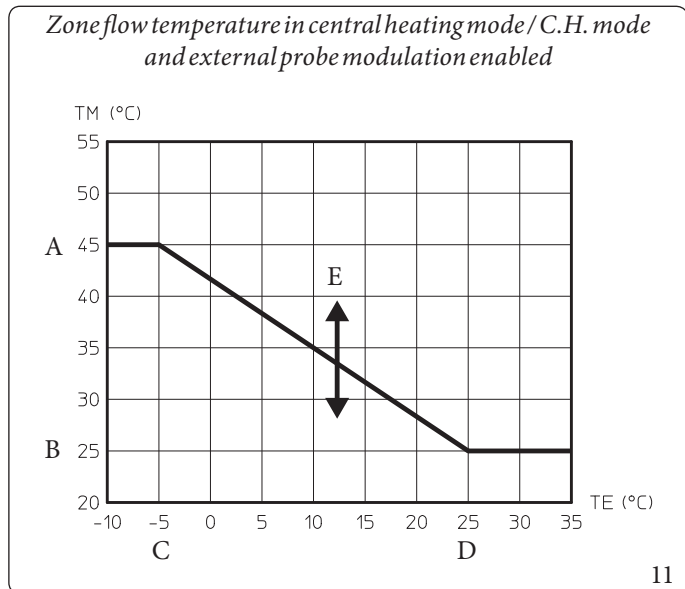

Key (Fig. 11, 12, 13, 14)

- A - Maximum flow set
- B - Minimum flow set
- C - External minimum temperature
- D - External maximum temperature

- E - C.H. flow temperature offset
- F - Central heating / C.H. flow set
- G - Cooling flow temperature offset
- H - Cooling flow set

1.16 SYSTEM FILLING

Once the indoor unit is connected, fill the system using the filling cock (Fig. 27).

The indoor unit has one incorporated automatic vent valve located on the circulator and another on the 3-way plate heat exchanger pipe (Fig. 27).

There is also a manual vent valve (Fig. 27) positioned on the top of the central heating / C.H. manifold, which it is recommended to open during the filling phase to completely eliminate the air from the system.



Make sure that the hoods are loosened.

The filling valve must be closed when the indoor unit pressure gauge indicates approximately 1.2 bar.



During these operations, enable the manual "De-aeration" functions, which lasts about 18 hours (Parag. 3.9).

1.17 OPERATING LIMITS

The appliance was designed to work in a specific range of outdoor temperatures and at a specific maximum flow temperature. The chart (Fig. 15, 16, 17) shows these limits.

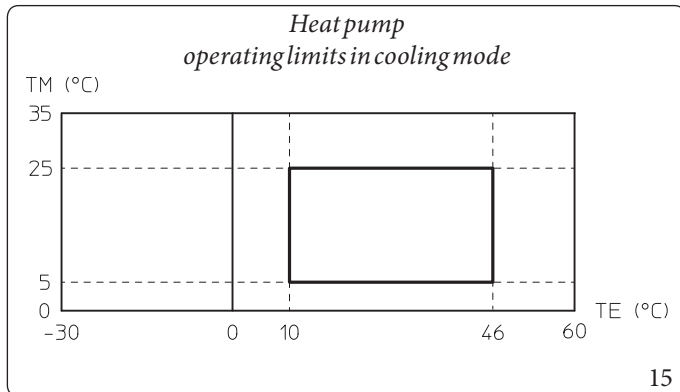

Key (Fig. 15):

TE = External temperature

TM = Flow temperature

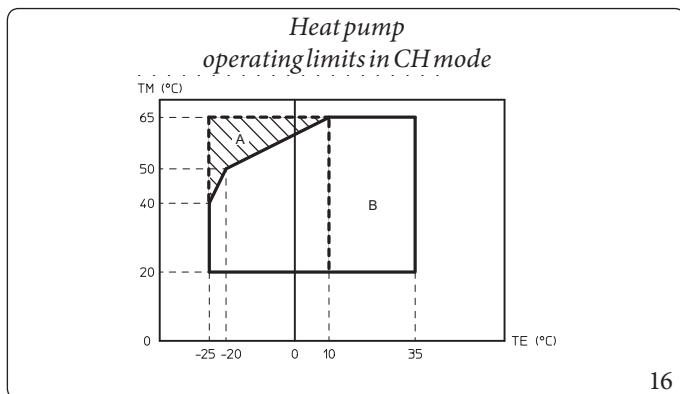

Key (Fig. 16):

TE = Temperatura esterna

TM = Flow temperature

A = Con resistenza elettrica impianto (optional)

B = Without electrical resistances enabled

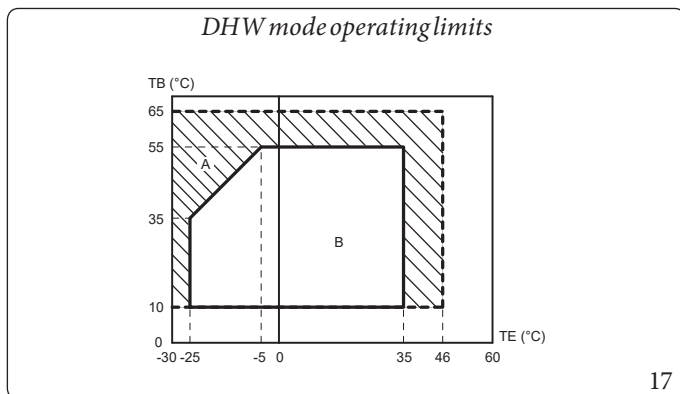

Key (Fig. 17):

TE = External temperature

TB = Storage tank temperature

A = With integration electrical resistance

B = Without electrical resistance enabled

1.18 INDOOR UNIT START-UP (IGNITION).

After having installed the chiller lines on the Outdoor Unit, to commission the heat pump (the operations listed below must only be performed by qualified personnel and in the presence of staff only):

1. Check connection to a 230V~50Hz power mains, correct L-N polarity and the earthing connection;
2. Switch the indoor unit on and check correct ignition;
3. Check the intervention of the main switch located upstream from the indoor unit and in the indoor unit.
4. Set the first ignition parameters (Par. 3.9).



The system must not be started up if even only one of the checks should be negative.



After installation, check for leaks. Toxic gas could be generated if the unit comes into contact with a source of ignition, such as thermal fan, stove and cylinders. Make sure that only refrigerant recovery cylinders are used.



Apply the product data nameplate contained inside the warranty envelope, in an accessible and visible position. Use the serial number on this plate for THERMAL/GSE practices.

1.19 CIRCULATION PUMP

The appliance is supplied with two circulators: the heat pump circulator, which deals with the heat exchange with outdoor unit, and the zone pump 1, which deals with the power supply to the system.

• Heat pump circulator UPM3

The appliance is supplied with a variable speed pump that adjusts the speed to ensure the best possible performance.

Pump LED.

The LED flashes green when the pump is powered and the control signal is connected.



The LED lights up steady green when the pump is powered and the signal cable disconnected. In these conditions the pump works at maximum speed and without control.

If the pump detects an alarm, the LED switches from green to red; this can mean one of the following failures:

- Low power supply voltage;
- Rotor seized;
- Electrical error.

For a detailed description of the meaning of the red LED, refer to the "Diagnostics in real time" table shown below.



The LED, in addition to being green or red, can also remain off.

It is normal for the LED to be off when the pump is not powered, whereas with the pump powered, the LED must be lit: if switched off, it means there is a fault.

Pump release.

If after a long period of inactivity, the circulator is blocked, adjust the screw in the centre of the head in order to manually release the motor shaft.

Take great care during this operation to avoid damage to the motor.

• Heat pump circulator UPM4

The appliance is supplied with a variable speed pump that adjusts the speed to ensure the best possible performance.

Pump symbols (Fig. 18):

With the pump powered and the pwm control signal connected and operating (pump ON or in stand-by), the symbol 2 flashes green ().

If the symbol 2 turns steady green (), the pump detects no command on the pwm signal and always runs at maximum speed.

If the pump detects an alarm, symbol 1 lights up red (). This can mean that there is one of the following faults:

- Low power supply voltage.
- Rotor seized (Cautiously turn the screw in the centre of the head to manually release the motor shaft).
- Electrical error.

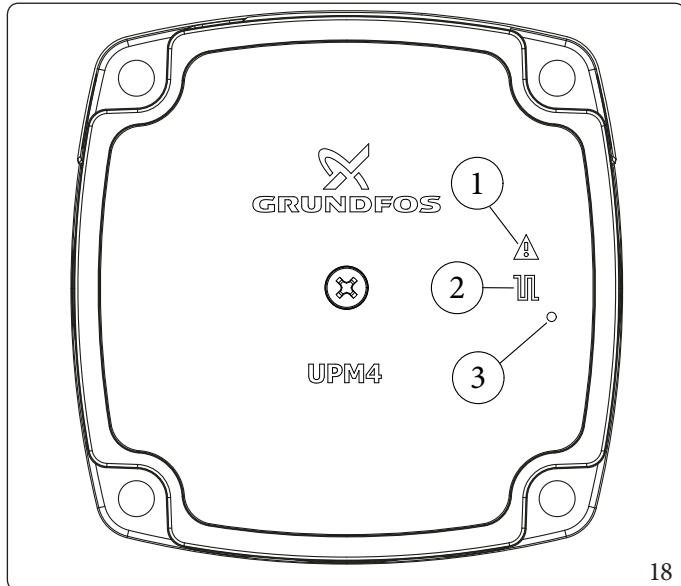

Key (Fig. 18):

- 1 - Alarm signal (Red)
- 2 - Functioning status signal (Steady green/Flashing green)
- 3 - Led (Not used on this model)

Pump release.

If after a long period of inactivity, the circulator is blocked, adjust the screw in the centre of the head in order to manually release the motor shaft.

Take great care during this operation to avoid damage to the motor.

• Zone 1 circulator pump

The pump is ideal for the requirements of each central heating system in a domestic and residential environment. In fact, the pump is equipped with electronic control that allows to set advanced functions.

Adjustment

Press the button on the front to adjust the pump.

By rotation, it is possible to select the following pump control mode:

- Fixed speed I, II, III.
- Proportional head I, II, III.
- Constant head I, II, III.

Fixed speed

Adjusts the pump speed in fixed mode.

It is possible to set 3 different speeds:

- I: Minimum Speed.
- II: Intermediate speed.
- III: Maximum speed.



Factory set speed = Fixed speed III

Proportional head ($\Delta P-V$)

This allows the pressure level (head) to be proportionally reduced as the system heat demand decreases (flow rate reduction).

Thanks to this function, the electric power consumption of the circulator pump is reduced further: the energy (power) used by the pump decreases according to the pressure level and flow rate.

With this setting, the pump guarantees optimal performance in most heating systems, thereby being particularly suitable in single-pipe and two-pipe installations.

Any noise originating from the water flow in the pipes, valves and radiators is eliminated by reducing the head.

Optimal conditions for thermal comfort and acoustic well-being.

Constant head ($\Delta P-C$)

The circulator pump maintains the pressure level (head) constant as the system heat demand decreases (flow rate reduction).

With these settings, the circulator pump is suitable for all floor systems where all the circuits must be balanced for the same drop in head.

Other functions:

- The **vent function** of the pump is activated by pressing and holding (3 seconds) the control key and automatically venting the pump. This function does not act on the central heating / C.H. system. The pump venting function starts and lasts 10 minutes. The two sets of upper and lower LEDs flash alternately every 1 second. To interrupt, press the control key for 3 seconds.
- The **manual restart** is activated by pressing and holding (5 seconds) the control key and releases the pump when needed (e.g. after prolonged inactivity periods during the summer period).
- The **keyboard block** is activated by pressing and holding (8 seconds) the control key and block the pump settings. The keyboard block protects against unintentional or unauthorised pump changes. Activate the keyboard block by pressing the control key for 8 seconds, until the selected setting LEDs flash briefly and then release. The LEDs flash continuously 1 second apart. If the keyboard block is active, the pump settings can no longer be modified. The deactivation of the keyboard block takes place in a similar manner to the activation.

Troubleshooting.

Faults	Causes	Solutions
Pump not working with power supply on.	Faulty electrical fuse	Check the fuses
	The pump is without voltage	Eliminate the power supply cut-off
The pump generates noise	Cavitation due to insufficient flow pressure	Increase the system pressure within the allowed field
		Check the head setting and eventually set a lower head
The building does not heat up.	Heat output of the radiant panels too low	Increase the delivery value
		Set the adjustment mode to ΔP -c instead of ΔP -v

Diagnostics in real time

- The anomaly LED indicates a fault.
- The pump stops (depending on the fault), and performs cyclical attempts to restart.

LED	Faults	Causes	Solutions
It lights up red	Block	Rotor seized	Activate the manual restart or contact the Authorised Technical Service Centre
	Contact/winding	Faulty winding	
It flashes with red light	Under/Overvoltage	Feed side power supply voltage too low/high	Check the mains voltage and operating conditions, ask the Authorised Technical Assistance Centre
	Excessive module temperature	Inside of the too hot module	
	Short-circuit	Motor current too high	
It flashes with red/green light	Turbine operation	The hydraulic system of the pumps is fed but the pump has no mains voltage	Check the mains voltage, the water pressure/ flow rate as well as the environmental conditions
	Dry operation	Air in the pump	
	Overload	The motor runs with difficulty. The pump complies with the specifications (e.g. high module temperature). The number of revolutions is lower than normal operation	

Manual restart

When a blockage is detected, the pump tries to automatically restart.

If the pump does not automatically restart:

- Activate the manual restart by pressing the control key for 5 seconds, then release.
- The restart function starts and last max. 10 minutes.
- The LEDs flash one after the other clockwise.
- To interrupt, press the control key for 5 seconds.

Zone 2/3 circulator pumps (optional)

The zone 2 and zone 3 pumps have the same functional characteristics as zone pump 1.

For the setting and management of anomalies, refer to zone pump 1.

Head available to the direct zone 1 system fixed speed

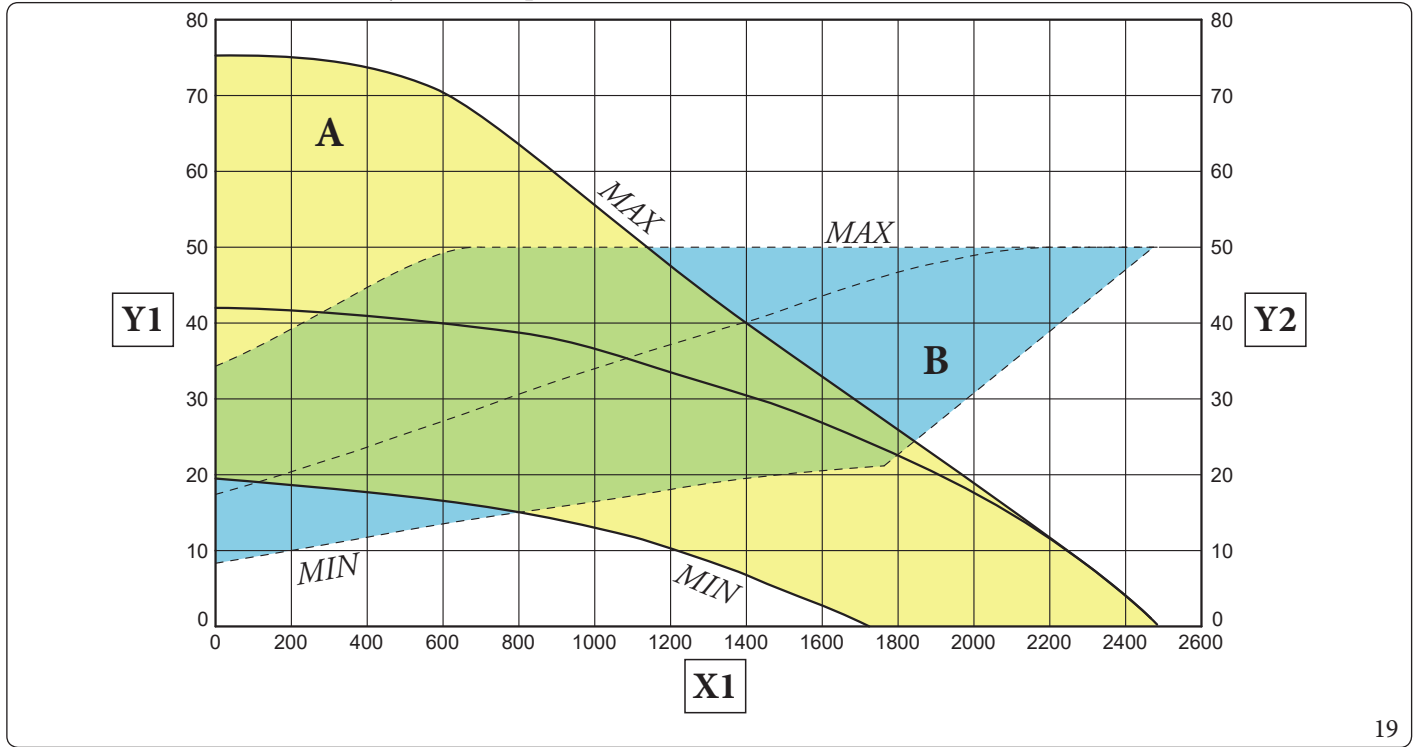

Key (Fig. 19):

X1 = Flowrate (l/h)

Y1 = Head (kPa)

Y2 = Circulator pump absorbed power (W)

A = Head available to the system

B = Absorbed power by the circulator (dotted area)

Head available to the proportional speed direct zone 1 system

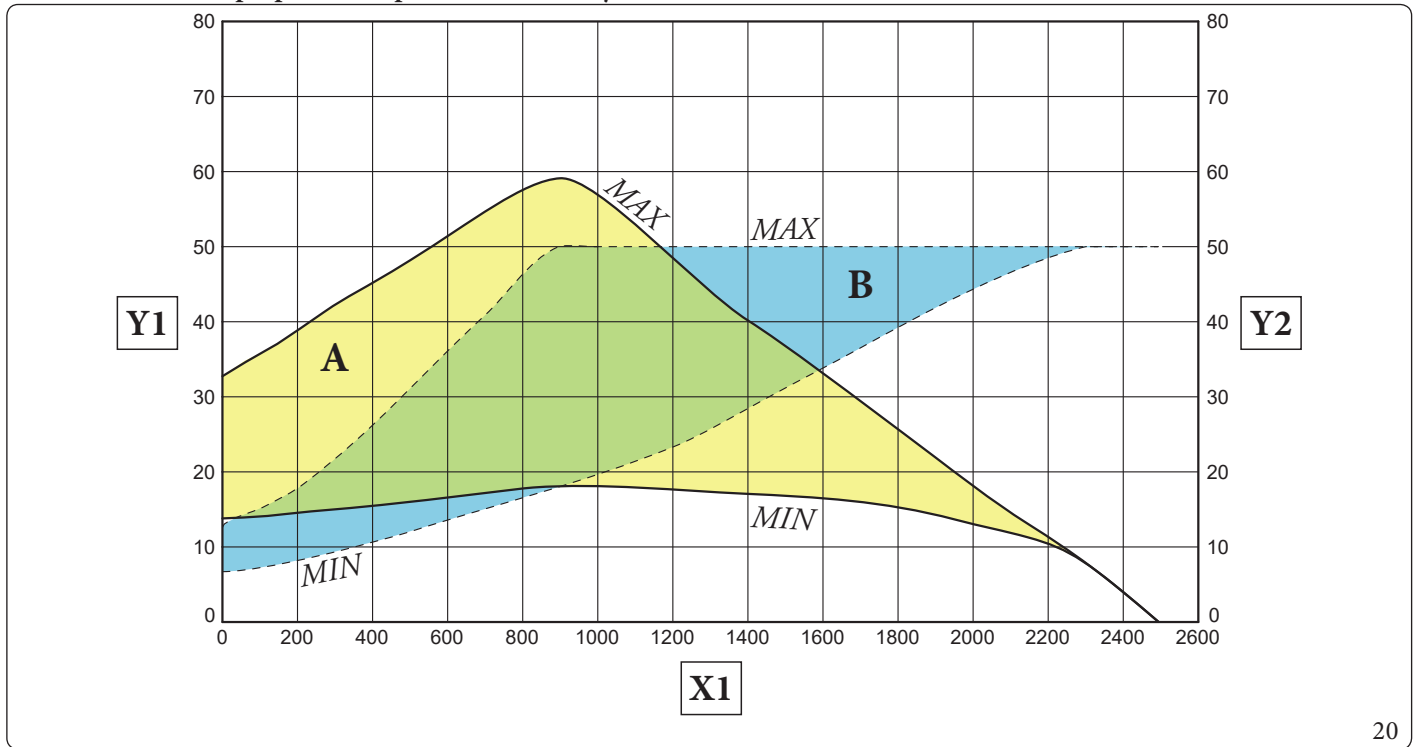

Key (Fig. 20):

X1 = Flowrate (l/h)

Y1 = Head (kPa)

Y2 = Circulator pump absorbed power (W)

A = Head available to the system

B = Absorbed power by the circulator (dotted area)

Head available to the direct zone 1 system constant speed

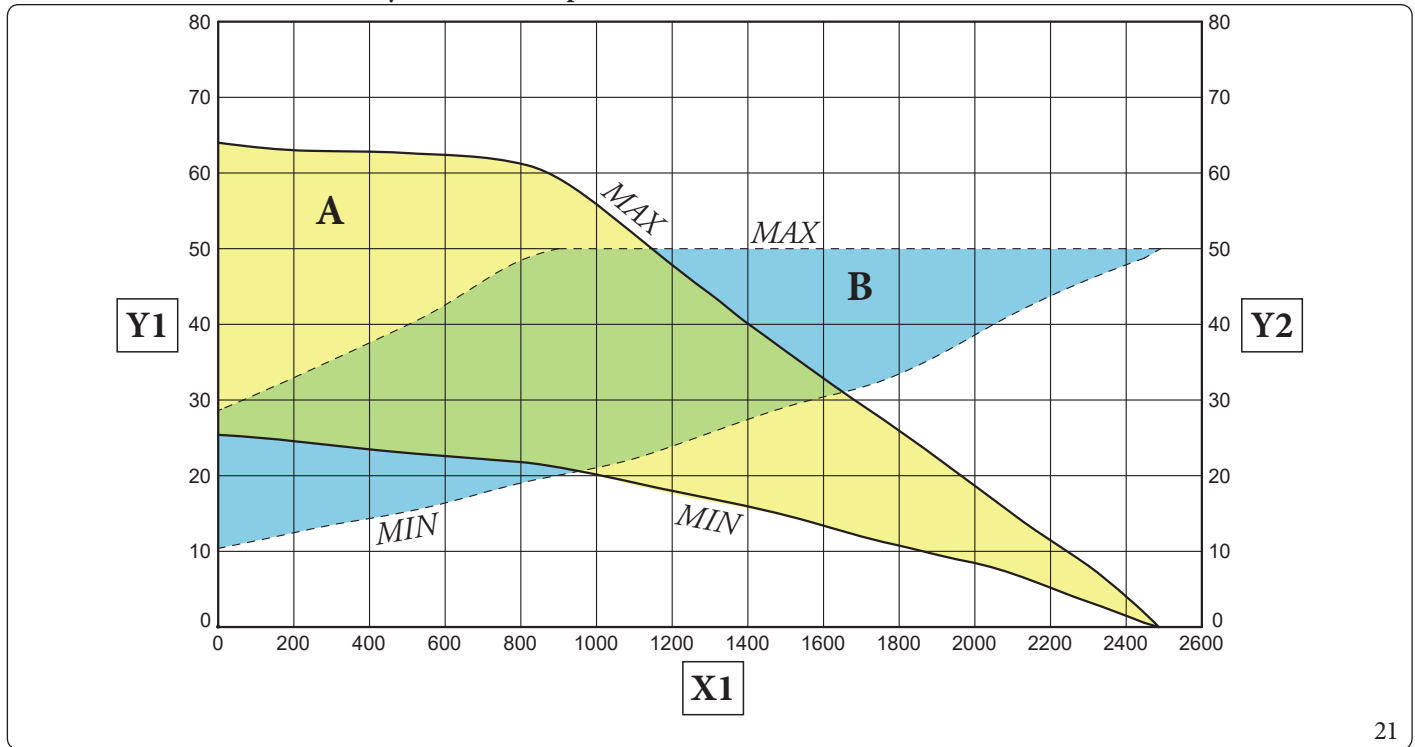

INSTALLER

USER

Key (Fig. 21):

- X1 = Flowrate (l/h)
- Y1 = Head (kPa)
- Y2 = Circulator pump absorbed power (W)

- A = Head available to the system
- B = Absorbed power by the circulator (dotted area)

21

Head available to the fixed speed mixed zone 2/3 system

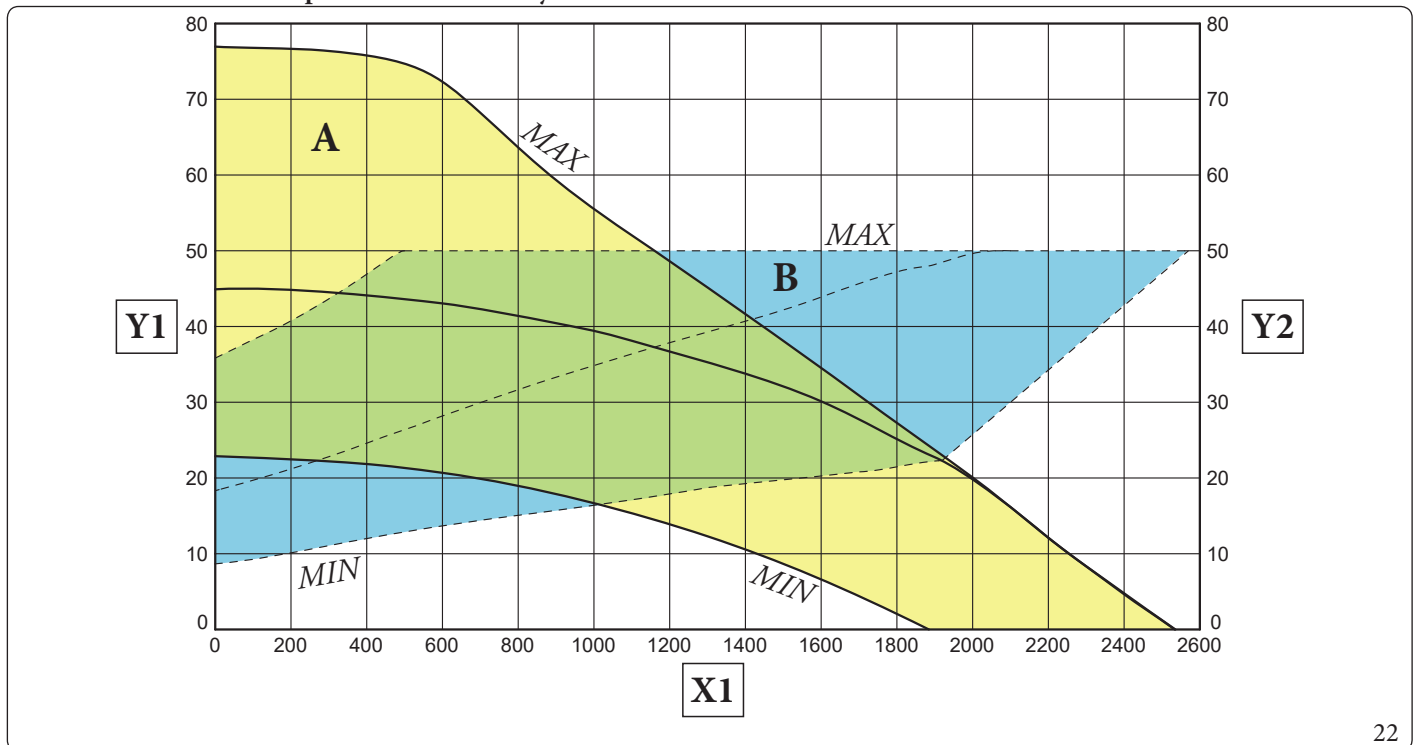

MAINTENANCE TECHNICIAN

TECHNICAL DATA

Key (Fig. 22):

- X1 = Flowrate (l/h)
- Y1 = Head (kPa)
- Y2 = Circulator pump absorbed power (W)

- A = Head available to the system
- B = Absorbed power by the circulator (dotted area)

22

Head available to the proportional speed mixed zone 2/3 system

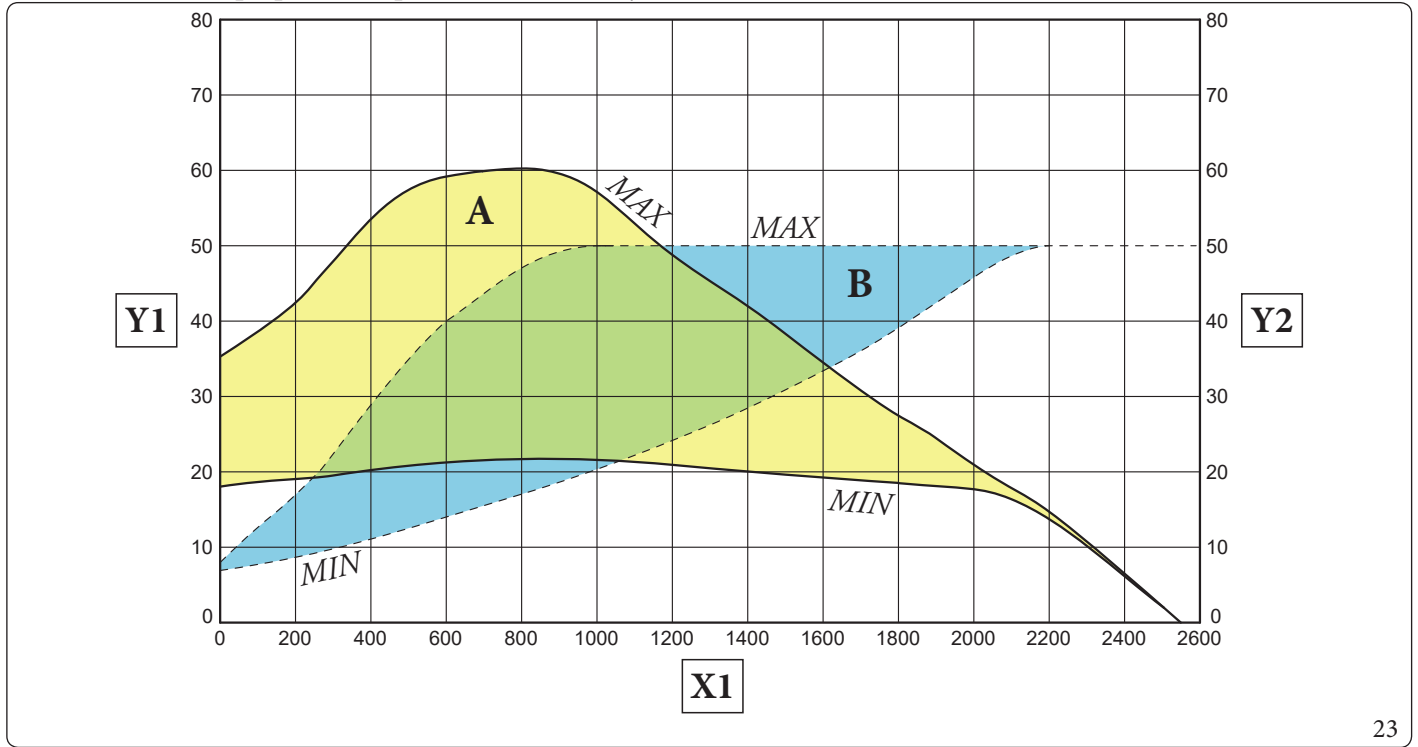

Key (Fig. 23):

X1 = Flowrate (l/h)

Y1 = Head (kPa)

Y2 = Circulator pump absorbed power (W)

A = Head available to the system

B = Absorbed power by the circulator (dotted area)

Head available to the constant speed mixed zone 2/3 system

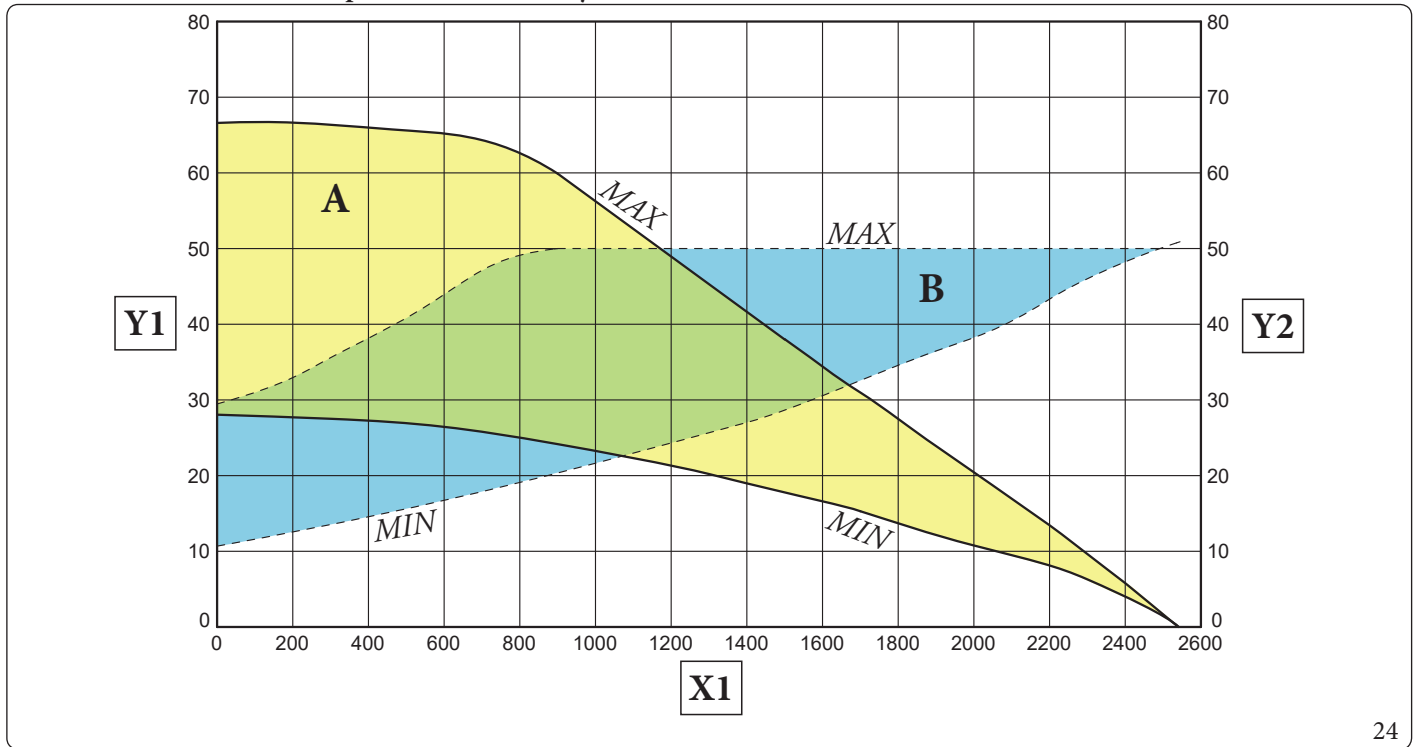

Key (Fig. 24):

X1 = Flowrate (l/h)

Y1 = Head (kPa)

Y2 = Circulator pump absorbed power (W)

A = Head available to the system

B = Absorbed power by the circulator (dotted area)

1.20 DOMESTIC HOT WATER STORAGE TANK UNIT

The storage tank in the appliance is the accumulation type with a capacity of 235 litres.

It contains large coiled stainless steel heat exchanger pipes, which allow to notably reduce hot water production times.

These storage tank units constructed with stainless steel casing and bottoms, guarantee long duration through time.

The assembly concepts and welding (T.I.G.) are implemented to the minimum detail to ensure maximum reliability.

The side inspection flange ensures practical control of the storage tank unit and the coiled heat exchanger and easy internal cleaning.

The Magnesium Anode (pos. 3 and 21, Fig. 27) holder caps include the same, are supplied as standard for the internal protection of the storage tank from possible corrosion. These caps are positioned on the side of the storage tank (pos. 3 and 21, Fig. 27).

Storage tank disassembly (Fig.25).

For easy maintenance or particular handling requirements, remove the storage tank as described below.

- To disassemble the storage tank unit, empty the appliance system by acting on the relevant drain fitting. Before carrying out this operation, make sure that the system filling valves are closed.
- Close the cold water inlet valve and open any domestic hot water valve.
- Drain the storage tank by means of the draining valve (9).
- Proceed to divide the appliance as described in the relative paragraphs 3.32 and 3.33.
- Loosen the nuts on the storage tank inlet and outlet pipes (1 and 6) and the cold inlet (7) and hot outlet (8) nuts on the storage tank (2).
- Loosen the nut (3) on the connection pipe to the DHW expansion vessel.
- Loosen the bracket (5) fixing screws (4) and remove the bracket itself.
- Slide the storage tank (2) to the front.

Work in reverse order to assemble the storage tank unit.

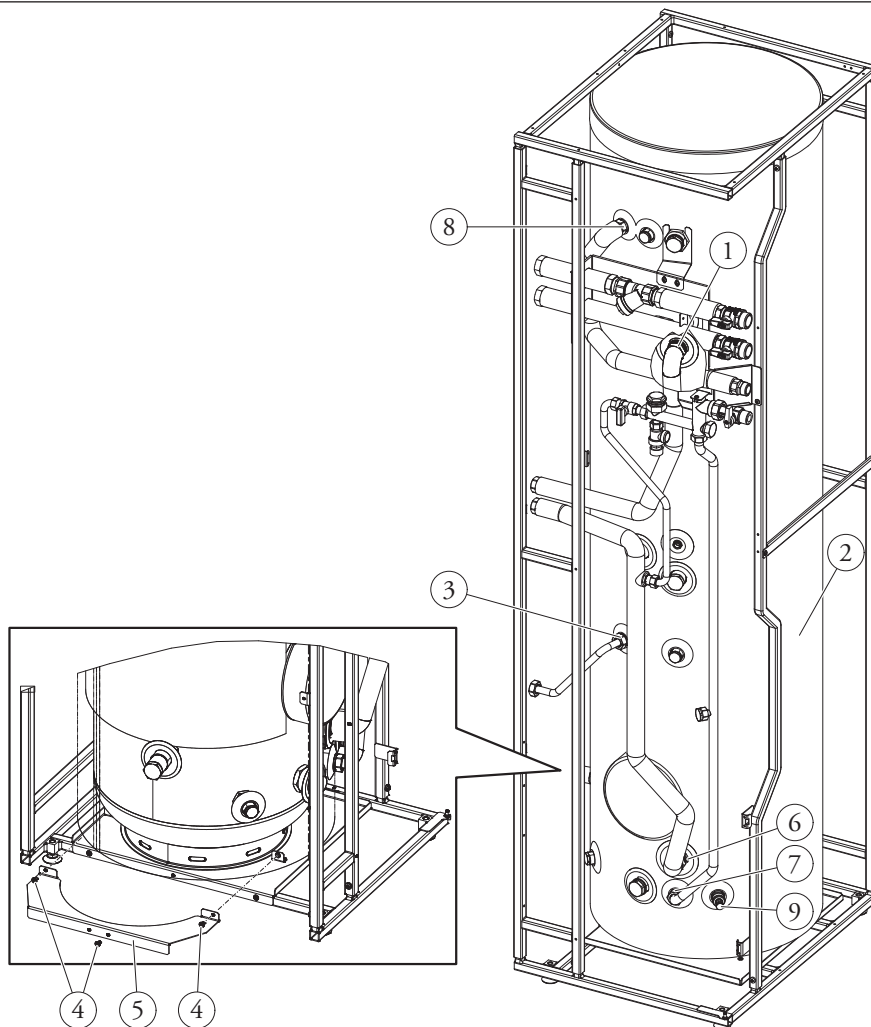

25

INSTALLER

USER

MAINTENANCE TECHNICIAN

TECHNICAL DATA

Condensate drainage present in the tray (Fig.26).

Under some operating conditions, condensate may form in the tray.

Make a drain hole on the ground towards the sewer system with an internal \varnothing of at least 13 mm.

To dispose of this condensate, insert the drain bend in the hole present on the bottom of the tray itself.

Connect the drainage elbow (1) to a hose that conveys the water to the desired point.

Make sure dust, debris and/or insects cannot enter this hose.

Also make sure that the liquid contained in it cannot freeze.

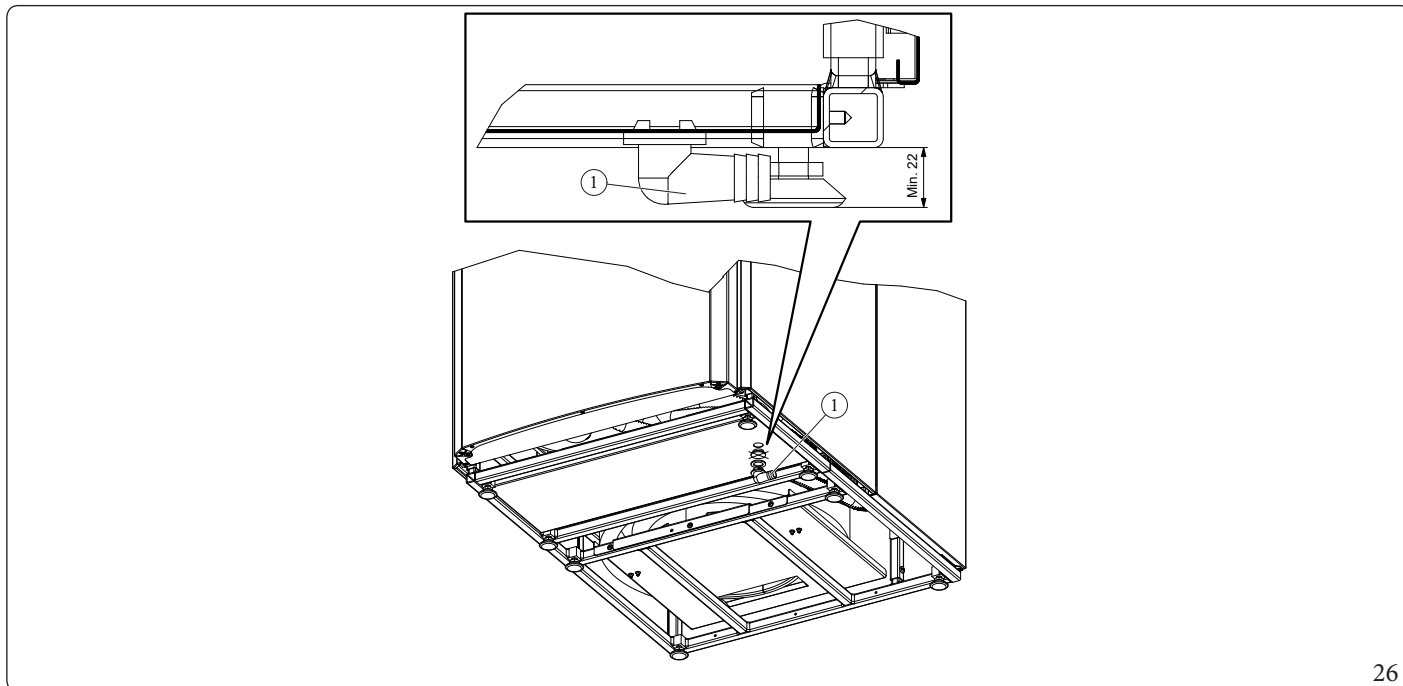

26

1.21 KITS AVAILABLE ON REQUEST



The flow probe of zone 1 (optional) is, on the other hand, mandatory with the installation of an external system integrative resistance.



Check the complete list of kits available and which can be combined with the product, consult the Immergas website, the Immergas Price List or the technical-commercial documentation (catalogues and data sheets).

1.22 MAIN COMPONENTS

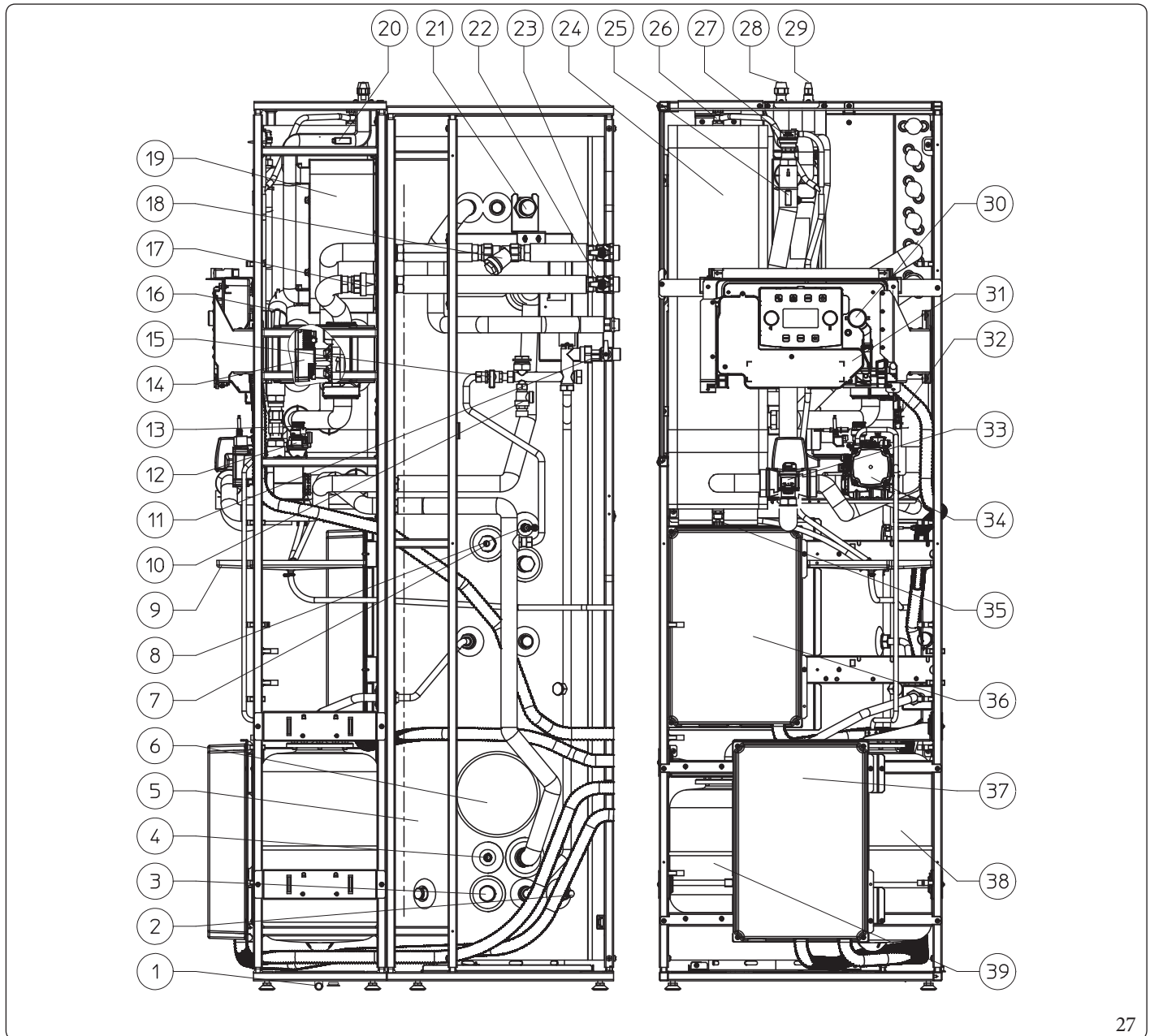

Key (Fig. 27):

- | | | |
|------------------------------------|---|---|
| 1 - Elbow fitting | 15 - System filling valve | 27 - Air vent valve |
| 2 - Storage tank draining valve | 16 - Heat pump return probe | 28 - Chiller line connection gaseous status |
| 3 - Sacrificial anode | 17 - One-way valve | 29 - Chiller line connection liquid status |
| 4 - Solar panels probe (optional) | 18 - Filter that can be inspected | 30 - System manometer |
| 5 - Stainless steel storage tank | 19 - Plate heat exchanger | 31 - Electrical connection compartment |
| 6 - Storage tank flange | 20 - Liquid phase detection probe | 32 - System flow-meter |
| 7 - DHW electrical resistance | 21 - Sacrificial anode | 33 - 3-way valve (motorised) |
| 8 - D.H.W. probe | 22 - System flow shut-off valve | 34 - Heat pump circulator |
| 9 - Condensate collection tray | 23 - System return shut-off valve | 35 - System draining valve |
| 10 - 8 bar safety valve | 24 - Hydraulic manifold | 36 - Main panel |
| 11 - Cold water inlet valve | 25 - Heat pump flow probe | 37 - Optional kit panel |
| 12 - Air vent valve | 26 - Hydraulic manifold manual air vent valve | 38 - System expansion vessel |
| 13 - 3 bar safety valve | | 39 - Domestic hot water expansion vessel |
| 14 - Direct zone 1 pump/circulator | | |

INSTALLER

USER

MAINTENANCE TECHNICIAN

TECHNICAL DATA

2 INSTRUCTIONS FOR USE AND MAINTENANCE

2.1 GENERAL RECOMMENDATIONS



Never expose the Indoor Unit to direct vapours from a hob.



The device can be used by children at least 8 years old as well as by persons with reduced physical, sensory or mental capabilities, or lack of experience or required knowledge, provided that they are under surveillance, or after they have been instructed relating to the safe use and have understood the potential dangers.

Children must not play with the appliance.

Cleaning and maintenance destined to be performed by the user can not be carried out by unsupervised children.



If temporary shutdown of the Indoor Unit is required, proceed as follows:

- a) drain the heating system if antifreeze is not used;
- b) shut off the electrical and water supply.



Never clean the appliance or connected parts with easily flammable substances.



Never leave containers or flammable substances in the same environment as the appliance.



Do not open or tamper with the appliance.



Only use the user interface devices listed in this section of the booklet.



Do not climb on the appliance, do not use the appliance as a support base.



In the event of malfunctions, faults or incorrect operation, turn the appliance off and contact an authorised company (e.g. the Authorised Technical Assistance Centre, which has specifically trained staff and original spare parts).

Do not attempt to modify or repair the appliance alone.



The use of components involving use of electrical power requires some fundamental rules to be observed such as:

- do not touch the appliance with wet or moist parts of the body; do not touch when barefoot;
- never pull electrical cables or leave the appliance exposed to atmospheric agents (rain, sunlight, etc.);
- the appliance power cable must not be replaced by the user;
- in the event of damage to the cable, switch off the appliance and contact exclusively qualified staff for replacement;
- if the appliance is not to be used for a certain period, disconnect the main Indoor Unit external switch.



Water at a temperature of more than 50°C can cause serious burns. Always check the water temperature before any use.



The temperatures indicated by the display have a tolerance of +/- 3°C due to environmental conditions that cannot be blamed on the Indoor Unit.



At the end of its service life, the appliance must not be disposed of like normal household waste nor abandoned in the environment, but must be removed by a professionally authorised company as required by current legislation. Contact the manufacturer for disposal instructions.

2.2 CLEANING AND MAINTENANCE



To preserve the system's integrity and keep the safety features, performance and reliability, which distinguish the assembly, unchanged over time, you must execute maintenance operations on a yearly basis in compliance with what is stated in the relative point at "annual check and maintenance of the appliance", in compliance with national, regional, or local standards in force.

2.3 CONTROL PANEL

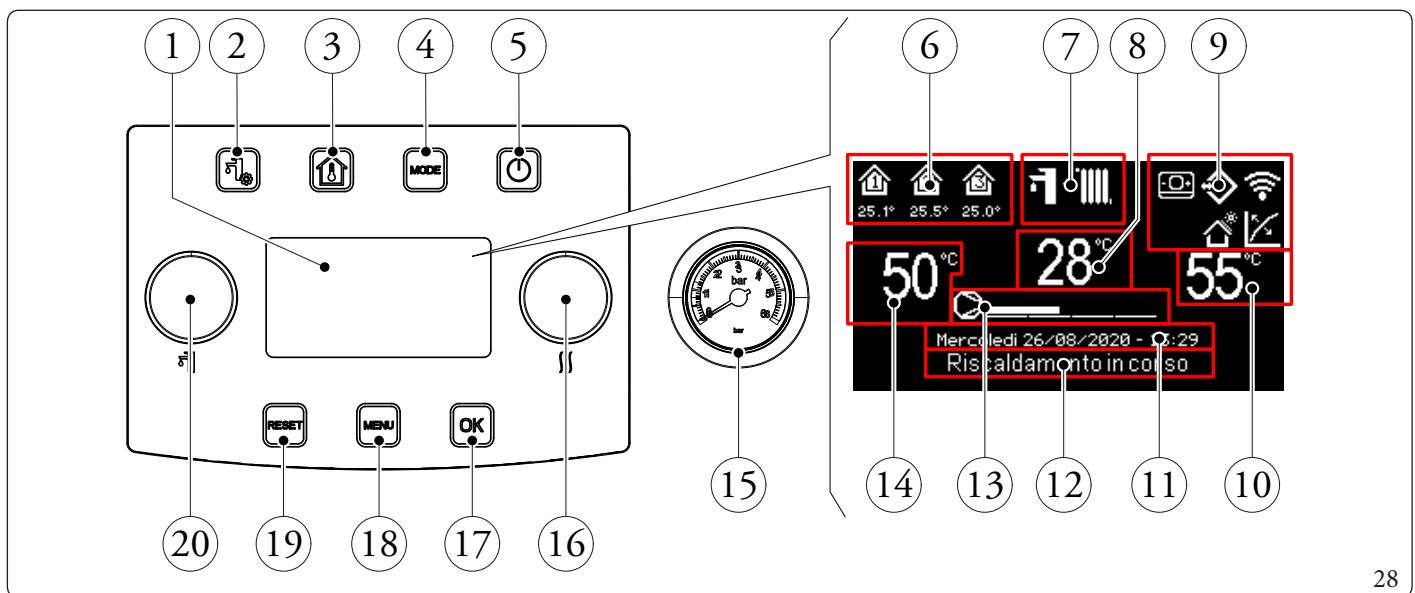

28

Key (Fig. 28):

- | | | | |
|----|---|----|---|
| 1 | - Display. | 11 | - Current date and time display. |
| 2 | - "DHW (Domestic hot water)" menu button. | 12 | - System status display. |
| 3 | - "Zones" button. | 13 | - Heat pump power scale display. |
| 4 | - Functioning mode button. | 14 | - DHW (Domestic hot water) set display. |
| 5 | - ON/OFF Button. | 15 | - Pressure gauge. |
| 6 | - Zones area (number and information of zone in use). | 16 | - "Heating/cooling set" knob. |
| 7 | - Operating mode. | 17 | - Selection confirmation/ok button. |
| 8 | - Anomaly code/flow temperature display. | 18 | - "Menu" Button. |
| 9 | - System general icon display. | 19 | - Anomalies/esc. reset button. |
| 10 | - Central heating/ C.H. set display. | 20 | - "Set DHW (Domestic hot water)" Knob. |

2.4 SYSTEM USE



Before ignition, make sure the system is full of water, checking that the pressure gauge needle (Fig. 28) points to a value between 1 and 1.2 bar and make sure that the chiller circuit has been filled as described in the outdoor unit instructions booklet.

The following are displayed upon ignition:

- Type of panel;
- Panel firmware version;
- Board firmware version.

Once the device has been powered, it goes into the status prior to switch-off. Press the “MODE” button to cyclically select the desired operating mode amongst those available.

The operating mode in use is indicated by its icon at the top of the display (Fig. 29) and is unique for all zones. By pressing any button, the pushbutton panel lights up for a few seconds; in this way it is activated and ready to receive the subsequent commands. Depending on the system's configuration, the main screen displays various information regarding the system itself, amongst which:

Symbol	Description and operation
	Zone identification icon. This icon reverses its colour during the central heating / C.H./cooling demand. The values below the zone icon, respectively indicate the temperature and the humidity detected in such zone
	Dominus enabled
	Zone remote panel presence icon
	Thermoregulation enabled on at least one zone
	Active holiday program
	Connection to temperature and humidity room probes
	Active photovoltaic function
	Outdoor unit compressor request

Operating mode	Description	DHW	Cooling	Central heating	Protection function (antifreeze, ...)
OFF	Off	Disabled	Disabled	Disabled	Disabled
	Summer	Enabled	Disabled	Disabled	Activated
	Summer with Cooling	Enabled	Enabled	Disabled	Activated
	Winter	Enabled	Disabled	Enabled	Activated
	Stand-by	Disabled	Disabled	Disabled	Activated

29

Below is a description of how to use the control panel, including:

- Enter the menus;
- Moving in the menus;
- Set a menu item;
- Confirming a change;
- Exit without saving.

• Enter the menus

The control panel menus can be accessed by pressing the buttons (Fig. 28):

- **Moving in the menus**

Simply rotate the “Set DHW (Domestic hot water)” knob to scroll the menu items.

The indication “[...]” next to the menu item indicates the availability of a submenu.

Press the “OK” button to access this submenu.

Pressing the “RESET” button goes back to the previous menu page.

- **Set menu item**

Go to the menu item to be set following the instructions given previously.

Once the menu item to be set is reached, press “OK” or rotate the “Set cooling/central heating / C.H.” knob to highlight the value to be changed.

Change the value by turning the “Set cooling/central heating / C.H.” knob.

- **Confirming a change**

At the end of the modification, press “OK” to confirm the change and go back to the previously selected menu item.

- **Exit without saving**

If at the end of the modification you press “RESET”, you will return to the previously selected menu item without confirming the modification.

2.5 OPERATING MODE

The indoor unit can work in the following modes:

- OFF;
- STAND-BY (❄️);
- SUMMER (🔥);
- SUMMER WITH COOLING (🔥 + ❄️);
- WINTER (🔥 + 🏠).

If the indoor unit is at "OFF", press the button "🔌" to activate it. If this is not the case, go to the next point.

Then press the "MODE" button in sequence to set the system to stand-by ❄️, summer 🔥, summer with cooling 🔥 + ❄️, winter 🔥 + 🏠 position.

- **"OFF" mode**

By pressing this button, the display will show "OFF" and the system will be off. In this mode, the safety functions are not guaranteed and the remote devices are disconnected (Fig. 29).



In these conditions the Indoor Unit is considered still live even if there are no functions active.

- **"Stand-by" Mode**

Press the "MODE" button in succession until the ❄️ symbol appears.

In this mode, the system is able to ensure protection functions only, such as: antifreeze function, antiblock function and any anomaly signals (Fig. 29).



In these conditions the system must still be considered powered.

- **Summer**

Press the "MODE" button in succession until the 🔥 symbol appears.

In this mode the system allows the production of domestic hot water and ensures protection (Fig. 29).

- **Summer with cooling**

Press the "MODE" button in succession until the "🔥 + ❄️" symbol appears.

In this mode the system allows the production of domestic hot water, room cooling and dehumidification and ensures protection (Fig. 29).

- **Winter**

Press the "MODE" button in succession until the "🔥 + 🏠" symbol appears.

In this mode the system allows the production of domestic hot water and room central heating / C.H. and ensures protection (Fig. 29).

List of functions

The following functions can be set on the internal unit:

- DHW (Domestic hot water);
- Central heating / C.H.;
- Cooling;
- Dehumidify.

DHW

The domestic hot water can be produced with the heat pump or with electrical resistance.

The system automatically manages the activation of the generators to heat up the domestic hot water in the storage tank.

During activation, 'DHW underway' appears on the display.

It is possible to set the domestic hot water temperature adjustment in two ways: MANUAL or AUTOMATIC.

The selection is made by entering the menu "DHW" ("DHW" button) and setting the parameter "Set Management".

Manual adjustment (Man)

Adjustment of the DHW temperature in MAN mode is done via the "DHW Set" knob (Fig. 28) or by changing the value "Manual set" within the "DHW" menu.

Confirmation can take place in two ways: by pressing the OK button or by waiting two minutes after changing the value.

Automatic adjustment (Auto)

The AUTOMATIC DHW temperature adjustment involves setting "Comfort set" and "Economy Set" parameters in the "DHW" menu and choosing the calendar inside the menu:

Clock and programs / DHW Program

In the selected time slots, the DHW set will be automatically set to the "Comfort Set" value; outside these, the set DHW will be set to "Economy Set" value.

It is possible to temporarily modify the DHW set by setting a manual value using the "Set DHW" knob (Fig. 28).

This setting will be lost when the time slot is next changed.

DHW (Domestic hot water) Boost

Activating the "DHW (Domestic hot water) Boost" function via the menu

DHW / Boost Function = On

DHW (Domestic hot water) operation takes place with the contribution of both the heat pump and the electrical resistance, with a logic that minimises storage tank charging time.

Central heating

It is possible to set the central heating / C.H. activation parameters for each individual zone in three different ways: MANUAL, AUTOMATIC, OFF.

The selection is made by entering the "Zones"  menu and after having selected the zone of interest, access the menu

Settings / Operation mode

There are two types of requests:

- Request from room temperature in the presence of remote control

Enablings / Enable remote contr. = Probe / Panel

- Request from TA (room thermostat)

Enablings / Enable room thermostat = Yes

- In the first case, the system works in the following way:

Manual adjustment (Man)

The central heating / C.H. request is adjusted according to a fixed room setpoint

C.H. / Manual set

When the room temperature is lower than the manual central heating / C.H. set, the appliance is started in central heating / C.H. mode.

Automatic adjustment (Auto)

There are two room temperature setpoints:

C.H. / Comfort Set

C.H. / Economy Set

By associating a calendar with the relevant zone program, it is possible to determine the time slots for activating the central heating / C.H. comfort set. The time slots not set, correspond to the central heating / C.H. economy set.

When the detected room temperature is below the central heating / C.H. set active at that moment, the appliance is activated in central heating / C.H. mode.

Adjustment OFF

Central heating / C.H. always off.

- In the second case, the system works in the following way:

Manual adjustment (Man)

The central heating / C.H. demand is activated according to the closing of the TA contact of the relative zone.

Automatic adjustment (Auto)

The central heating / C.H. demand is activated according to the closing of the TA contact of the relative zone, during zone presence in the comfort band.

Adjustment OFF

Central heating / C.H. always off.

Cooling

It is possible to set the cooling activation parameters for each individual zone in three different ways: MANUAL, AUTOMATIC, OFF.

The selection is made by entering the "Zones"  menu and after having selected the zone of interest, access the menu

Settings / Operation mode

There are two types of requests:

- Request from room temperature in the presence of remote control

Enablings / Enable remote contr. = Probe / Panel

- Request from TA (room thermostat)

Enablings / Enable room thermostat = Yes

- In the first case, the system works in the following way:

Manual adjustment (Man)

The cooling request is adjusted according to a fixed room setpoint

Cooling / Manual set

When the room temperature is higher than the manual cooling set, the appliance is started in cooling mode.

Automatic adjustment (Auto)

There are two reference setpoints:

Cooling / Comfort Set

Cooling / Economy Set

By associating a calendar with the relevant zone program, it is possible to determine the time slots for activating the cooling comfort set. The time slots not set, correspond to the cooling economy set.

When the detected room temperature is above the cooling set active at that moment, the appliance is activated in cooling mode.

Adjustment OFF

Cooling always off.

- In the second case, the system works in the following way:

Manual adjustment (Man)

The cooling demand is activated according to the closing of the TA contact of the relative zone.

Automatic adjustment (Auto)

The cooling demand is activated according to the closing of the TA contact of the relative zone, during zone presence in the comfort band.

Adjustment OFF

Cooling always off.

Dehumidify

If the system is coupled to a humidistat (optional) or a remote zone panel (optional) or a temperature and humidity probe (optional), you can manage the room humidity in summer air conditioning mode.

- If coupled to a humidistat, set the degree of humidity on the humidistat itself (see the instruction booklet).
- If coupled to a humidity temperature sensor, set the humidity percentage in the relative user menu.
- If coupled to a zone remote panel, set the humidity percentage in the relative user menu of the control panel or directly in the menu of the panel (see instruction booklet).

The dehumidification adjustment parameters can be set by entering the "Zone"  menu and selecting the zone of interest by accessing the settings menu and finally the menu

Dehumidification / Set room humidity

Dehumidification disabling

It is possible to disable dehumidification for a time slot, typically a night time slot, by setting

Dehumidification / Hourly disabling = Yes

and the start and end times of disabling.



In central heating or cooling request mode, if the temperature of the water in the system meets the request, the system can work simply by activating the circulator pump.

Clock and programs

From this menu, it is possible to set the system's date and time as well as the time slots for operation in Comfort and Economy mode.

- **Date and time.**

The date and time can be set by modifying the parameters in the menu

Clock and programs / Set date and time



The screenshot shows a menu titled "Set date and time" with the following parameters:

TIME	22:22
DAY	5
MONTH	1
YEAR	2020

30

- **Time slots**

It is possible to set 4 calendars with 4 time operating slots in system comfort mode. The system will operate in economy mode during out-of-range time of these 4 time slots.

After setting these 4 calendars it is possible to associate them to the various days of the week in the zone programs, DHW (Domestic hot water) and recirculation according to one's needs.

Set the time slots by modifying the menu

Clock and programs / Time slots

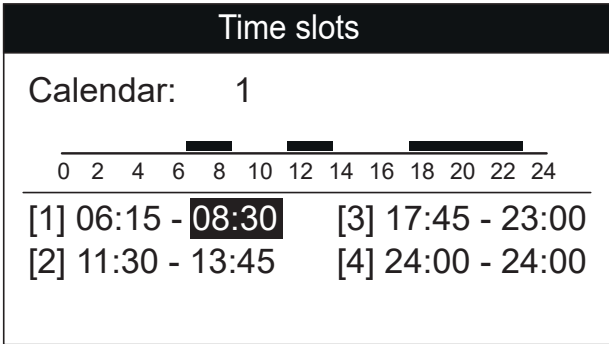

The screenshot shows a menu titled "Time slots" with the following information:

Calendar: 1

A bar chart shows four time slots on a 24-hour scale:

- [1] 06:15 - 08:30
- [2] 11:30 - 13:45
- [3] 17:45 - 23:00
- [4] 24:00 - 24:00

31

- **Program for Zone 1, Zone 2 (if present), Zone 3 (if present), DHW (Domestic hot water) and recirculation.**
Time ranges (calendars from 1 to 4) are assigned to Zone 1, Zone 2 (if present), Zone 3 (if present), DHW (Domestic hot water) and Central heating / C.H. in these menus.
You can assign the calendar to a single day or to a group of days (single day, Monday - Friday, Saturday - Sunday, Monday - Saturday, Monday - Sunday).
Therefore each day may be personalised with 4 different operating programs.
For convenient selection, the bottom part displays the graphics of the relevant calendar being selected (Fig. 32).

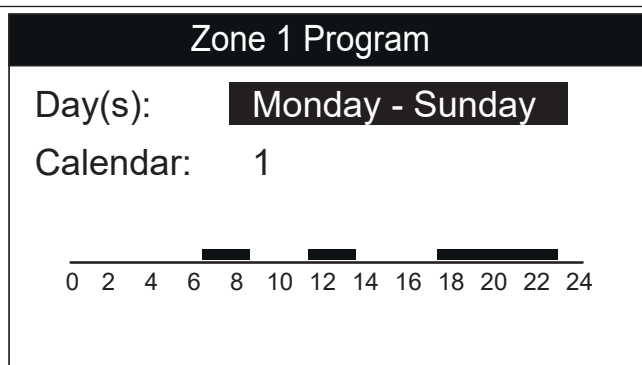

32



On the menu

Zone / Information

it is possible to identify the status of the various controls managing the central heating / C.H..

- **Holiday program.**
If required, it is possible to pause system operation for an established period.
Time and program/Holiday program
Set the period in which you wish to pause system operation. During this time, the previously set calendars will not be taken into consideration.
The antifreeze function is still ensured during the holiday period.

Heat pump disabling

It is possible to disable the heat pump operation for a certain time slot, by setting

User / Disable HP = Yes

and the start and end times of disabling.

Integration Disabling

The use of the integration electrical resistances can be permanently disabled by setting

User / Disable Integration = Yes

Automatic Vent Function

In the case of new systems and, in particular, for floor systems, it is very important that de-aeration is performed correctly.

The function consists of the cyclic activation of the pumps and the 3-way valve.

The function is activated by setting

User / Enable func. Deaeration = Yes

De-aeration lasts 9 hours and it can be interrupted by setting

User / Enable func. Deaeration = No

Screed Heater Function

The Indoor Unit is equipped with a function to perform the thermal shock on new radiant panel systems, as required by the applicable standard.



Contact the manufacturer of the radiant panels for the thermal shock characteristics and its correct execution.



To be able to activate the function there must be no remote control connected, while in case of system divided into zones it must be properly connected, both hydraulically and electrically.

The active zone pumps are those with ongoing requests, made via the room thermostat input.

The standard function lasts in total 7 days - 3 days at the lowest temperature set and 4 days at the highest temperature set (Fig. 33).

Duration can be changed by changing the value of the parameters

Screed heater / Min dwell time set

Screed heater / Max dwell time set

and the temperature gradients within the same menu.

The function is activated from the indoor unit in stand-by, by accessing the menu

Screed heater / Activation

At this point, "Screed heater underway" appears on the display.

In case of failure, the function is suspended and will resume when normal operating conditions are reset from the point where it was interrupted.

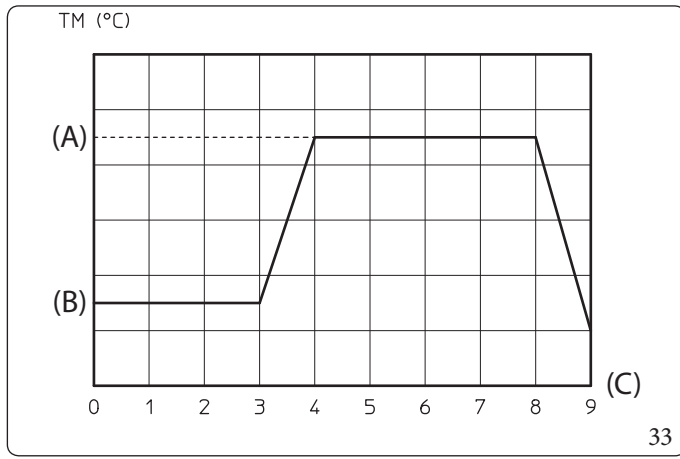

Key (Fig. 33):

(A) - Top set

(B) - Low set

(C) - Days

Operation with external probe

It is possible to use the thermoregulation functions associated to an external probe.

The system is standard set up to use the outdoor unit external probe or an optional external probe.

With the external probe connected and the thermoregulation function active, the system flow setpoint for room central heating / C.H. or cooling is managed by the system according to the outdoor temperature measured (Par. 1.12).

You can correct the flow setpoint by choosing the offset value in the specific user menu.

It is possible to enable thermal adjustment for each individual zone. The symbol is present in case of thermoregulation of at least one zone.

Room Antifreeze Function

The room frost protection function serves to ensure the protection of system components. If the room temperature of the zone falls below the limit set in the 'Special Parameters' menu, the heat pump is switched on until the set antifreeze protection temperature increased by 1°C is reached.

To enable this function, a zone remote panel or a zone humidity temperature probe is required.

2.6 PARAMETERS AND INFORMATION MENU

“DHW (Domestic hot water)” Menu.

Press the “DHW (Domestic hot water)” button to access a list of variables that enable you to customise use of the DHW (Domestic hot water).

Hereunder is a list of available menus:



The following menus refer to display board firmware rev. 2.00 and supervision board rev. 2.01.

DHW				
Menu item	Description	Range	Default	Customised value
Boost Function	Enabling of DHW (Domestic hot water) BOOST function	Off / On / Auto	Off	
Set Management	Enabling of the DHW (Domestic hot water) setpoint management in Automatic mode	Manual / Auto	Manual	
Comfort Set	Domestic hot water accumulation setpoint in Comfort phase (Automatic mode)	20 ÷ 65 °C	20 °C	
Economy Set	Domestic hot water accumulation setpoint in Economy phase (Automatic mode)	10 ÷ 35 °C	10 °C	
Manual set	Domestic hot water accumulation setpoint in Manual phase	10 ÷ 65 °C	10 °C	
Temperature	Display of the DHW (Domestic hot water) temperature	-	-	

Zones Menu.

Press the "Zones" BUTTON  to access a list of variables that enable you to customise use of the zones.

Below is the complete list of available menus, some of which are only visible after enabling the component or activating the specific associated function:

Zones	
Menu item	Description
Zone 1	Defines the operating parameters to manage zone 1.
Zone 2 (*)	Defines the operating parameters to manage the zone 2 (if present).
Zone 3 (*)	Defines the operating parameters to manage the zone 3 (if present).
General information	This display system operating data.

(*) if present.

Zones / Zone 1	
Menu item	Description
Information	This displays the system operating data.
Settings	Defines the operating parameters to manage zone 1.

Zones / Zone 1 / Information	
Menu item	Description
Room temperature	Room temperature on zone 1
Room humidity	Zone 1 room humidity
Dew temperature	Zone 1 dew temperature
Set room temperature	Room setpoint set on zone 1
Room humidity set	Room humidity setpoint set on zone 1
Flow set	Flow setpoint on zone 1
Flow temperature	Flow temperature set on zone 1
Operation status (**)	Description of the zone 1 operating mode Off = zone in OFF mode Economy = Zone in economy mode Comfort = zone in comfort mode Manual = zone in manual mode
Room Thermostat Stat. (**)	Yes = Zone TA contact closed No = TA contact open

(**) Menu entry only visible with "Service" access.

Zones/Zone 1/Settings				
Menu item	Description	Range	Default	Customised value
Operation mode	Setting of the zone 1 operating mode. Off = zone in OFF mode Auto = Zone in Automatic mode Manual = zone in manual mode	Off/Manual/ Auto	Auto	
C.H.				
Cooling				
Dehumidification				

Zones/Zone 1/Settings/C.H.				
Menu item	Description	Range	Default	Customised value
Comfort Set	Room setpoint in central heating zone 1 Comfort mode (Auto mode)	10 ÷ 35°C	20°C	
Economy Set	Room setpoint in central heating zone 1 Economy mode (Auto mode)	5 ÷ 30°C	16°C	
Manual set	Room setpoint in central heating zone 1 manual mode	5 ÷ 35°C	20°C	
Flow set	Flow setpoint set for zone 1 in central heating/C.H.	10 – 65°C	25°C	
Flow offset	Offset temperature for central heating zone 1	-9 ÷ +9°C	0°C	

Zones/Zone 1/Settings/Cooling				
Menu item	Description	Range	Default	Customised value
Comfort Set	Room temperature in cooling zone 1 in Comfort mode (Auto mode)	10 ÷ 35°C	25°C	
Economy Set	Room temperature in cooling zone 1 in Economy mode (Auto mode)	5 ÷ 30°C	28°C	
Manual set	Room setpoint in cooling zone 1 manual mode	5 ÷ 35°C	25°C	
Flow set	Flow setpoint set for zone 1 in cooling	5 ÷ 25°C	20°C	
Flow offset	Offset temperature for cooling zone 1	-9 ÷ +9°C	0°C	

Zones/Zone 1/Settings/Dehumidification				
Menu item	Description	Range	Default	Customised value
Set humidity	Humidity setpoint for zone 1	30 ÷ 70 %	50 %	
Hourly disabling	Disabling of request to the dehumidifier, according to the daily time slot	No/Yes	No	
Hourly disable start	Time of dehumidification request disabling phase start	0-23h	22h	
Hourly disable end	Time of dehumidification request disabling phase end	0-23h	8h	

Zones / Zone2 (*)	
Menu item	Description
Information	This displays the system operating data.
Settings	Defines the operating parameters to manage the zone 2.

(*) if present.

Zones / Zone2 (*) / Information	
Menu item	Description
Room temperature	Room temperature on zone 2
Room humidity	Zone 2 room humidity
Dew temperature	Zone 2 dew temperature
Set room temperature	Room setpoint set on zone 2
Room humidity set	Room humidity setpoint set on zone 2
Flow set	Flow setpoint on zone 2
Flow temperature	Flow temperature set on zone 2
Operation status (**)	Description of the zone 2 operating mode Off = zone in OFF mode Economy = Zone in economy mode Comfort = zone in comfort mode Manual = zone in manual mode
Room Thermostat Stat. (**)	Yes = Zone TA contact closed No = TA contact open

(*) if present.

(**) Menu entry only visible with "Service" access.

Zones / Zone2 (*) / Settings				
Menu item	Description	Range	Default	Customised value
Operation mode	Setting of the zone 2 operating mode. Off = zone in OFF mode Auto = Zone in Automatic mode Manual = zone in manual mode	Off / Manual / Auto	Auto	
C.H.				
Cooling				
Dehumidification				

(*) if present.

INSTALLER

USER

MAINTENANCE TECHNICIAN

TECHNICAL DATA

Zones / Zone 2 (*) / Settings / C.H.				
Menu item	Description	Range	Default	Customised value
Comfort Set	Room setpoint in central heating zone 2 Comfort mode (Auto mode)	10 ÷ 35°C	20°C	
Economy Set	Room setpoint in central heating zone 2 Economy mode (Auto mode)	5 ÷ 30°C	16°C	
Manual set	Room setpoint in central heating zone 2 manual mode	5 ÷ 35°C	20°C	
Flow set	Flow setpoint set for zone 2 in central heating / C.H.	10 – 65°C	25°C	
Flow offset	Offset temperature for central heating zone 2	-9 ÷ +9°C	0°C	

(*) if present.

Zones / Zone 2 (*) / Settings / Cooling				
Menu item	Description	Range	Default	Customised value
Comfort Set	Room temperature in cooling zone 2 in Comfort mode (Auto mode)	10 ÷ 35°C	25°C	
Economy Set	Room temperature in cooling zone 2 in Economy mode (Auto mode)	5 ÷ 30°C	28°C	
Manual set	Room setpoint in cooling zone 2 manual mode	5 ÷ 35°C	25°C	
Flow set	Flow setpoint set for zone 2 in cooling	5 ÷ 25°C	20°C	
Flow offset	Offset temperature for cooling zone 2	-9 ÷ +9°C	0°C	

(*) if present.

Zones / Zone 2 (*) / Settings / Dehumidification				
Menu item	Description	Range	Default	Customised value
Set humidity	Humidity setpoint for zone 2	30 ÷ 70%	50%	
Hourly disabling	Disabling of request to the dehumidifier, according to the daily time slot	No / Yes	No	
Hourly disable start	Time of dehumidification request disabling phase start	0-23h	22h	
Hourly disable end	Time of dehumidification request disabling phase end	0-23h	8h	

(*) if present.

Zones / Zone 3 (*)	
Menu item	Description
Information	This displays the system operating data.
Settings	Defines the operating parameters to manage the zone 3.

(*) if present.

Zones / Zone 3 (*) / Information	
Menu item	Description
Room temperature	Room temperature on zone 3
Room humidity	Zone 3 room humidity
Dew temperature	Zone 3 dew temperature
Set room temperature	Room setpoint set on zone 3
Room humidity set	Room humidity setpoint set on zone 3
Flow set	Flow setpoint on zone 3
Flow temperature	Flow temperature set on zone 3
Operation status (**)	Description of the zone 3 operating mode Off = zone in OFF mode Economy = Zone in economy mode Comfort = zone in comfort mode Manual = zone in manual mode
Room Thermostat Stat. (**)	Yes = Zone TA contact closed No = TA contact open

(*) if present.

(**) Menu entry only visible with "Service" access.

Zones / Zone 3 (*) / Settings				
Menu item	Description	Range	Default	Customised value
Operation mode	Setting of the zone 3 operating mode. Off = zone in OFF mode Auto = Zone in Automatic mode Manual = zone in manual mode	Off / Manual / Auto	Auto	
C.H.				
Cooling				
Dehumidification				

(*) if present.

INSTALLER

USER

MAINTENANCE TECHNICIAN

TECHNICAL DATA

Zones / Zone 3 (*) / Settings / C.H.				
Menu item	Description	Range	Default	Customised value
Comfort Set	Room setpoint in central heating zone 3 Comfort mode (Auto mode)	10 ÷ 35°C	20°C	
Economy Set	Room setpoint in central heating zone 3 Economy mode (Auto mode)	5 ÷ 30°C	16°C	
Manual set	Room setpoint in central heating zone 3 manual mode	5 ÷ 35°C	20°C	
Flow set	Flow setpoint set for zone 3 in central heating / C.H.	10 – 65°C	25°C	
Flow offset	Offset temperature for central heating zone 3	-9 ÷ +9°C	0°C	

(*) if present.

Zones / Zone 3 (*) / Settings / Cooling				
Menu item	Description	Range	Default	Customised value
Comfort Set	Room temperature in cooling zone 3 in Comfort mode (Auto mode)	10 ÷ 35°C	25°C	
Economy Set	Room temperature in cooling zone 3 in Economy mode (Auto mode)	5 ÷ 30°C	28°C	
Manual set	Room setpoint in cooling zone 3 manual mode	5 ÷ 35°C	25°C	
Flow set	Flow setpoint set for zone 3 in cooling	5 ÷ 25°C	20°C	
Flow offset	Offset temperature for cooling zone 3	-9 ÷ +9°C	0°C	

(*) if present.

Zones / Zone 3 (*) / Settings / Dehumidification				
Menu item	Description	Range	Default	Customised value
Set humidity	Humidity setpoint for zone 3	30 ÷ 70%	50%	
Hourly disabling	Disabling of request to the dehumidifier, according to the daily timeslot	No / Yes	No	
Hourly disable start	Time of dehumidification request disabling phase start	0-23h	22h	
Hourly disable end	Time of dehumidification request disabling phase end	0-23h	8h	

(*) if present.

Zones/General information

Menuitem	Description	Range	Default	Customised value
Outside temperature	External temperature detected by the external probe	-	-	
System flow set	Flow temperature set on the system	-	-	
Zone 1 flow set	Flow temperature set on zone 1	-	-	
Zone 1 request	Request present on zone 1 No = no request CH = Central heating request Cool. = Cooling request Dehumid. = Dehumidification request in neutral air R. Air = Dehumidification request in cooled air R + D = Cooling and dehumidification requests in neutral air R + A = Cooling and dehumidification requests in cool air	No CH Cool. Dehumid. R. Air R + D R + A	-	
Zone 2 flow set (*)	Flow temperature set on zone 2 (if present)	-	-	
Zone 2 request (*)	Request present on zone 2 No = no request CH = Central heating request Cool. = Cooling request Dehumid. = Dehumidification request in neutral air R. Air = Dehumidification request in cooled air R + D = Cooling and dehumidification requests in neutral air R + A = Cooling and dehumidification requests in cool air	No CH Cool. Dehumid. R. Air R + D R + A	-	
Zone 3 flow set (*)	Flow temperature set on zone 3 (if present)	-	-	
Zone 3 request (*)	Request present on zone 3 No = no request CH = Central heating request Cool. = Cooling request Dehumid. = Dehumidification request in neutral air R. Air = Dehumidification request in cooled air R + D = Cooling and dehumidification requests in neutral air R + A = Cooling and dehumidification requests in cool air	No CH Cool. Dehumid. R. Air R + D R + A	-	

(*) if present.

INSTALLER

USER

MAINTENANCE TECHNICIAN

TECHNICAL DATA

Main Menu

Press the "MENU" button to access a list of variables that enable you to customise use of the system. Hereunder is a list of available menus:

Menu	
Menu item	Description
Clock and programs	Defines the date/time and time operating slots
User	Defines the system parameters that can be modified by the user
Information	Display system operating data
Anomalies log	Displays the list of the last 10 anomalies
General settings	Allows selecting the panel operating language, the display operating mode and to access the password-protected menus dedicated to a qualified technician.

Menu/ Clock and programs				
Menu item	Description	Range	Default	Customised value
Set date and time	Defines the system clock and calendar	-	-	
Automatic summer time	Defines whether to activate the summer time changeover	Yes/No	Yes	
Time slots	Set the 4 time slots of each calendar.	00.00 - 24.00h	-	
Zone 1 Program	Zone 1 time scheduling	-	-	
	Zone 1: Monday	CAL1,CAL2, CAL3,CAL4	CAL1	
	Zone 1: Tuesday	CAL1,CAL2, CAL3,CAL4	CAL1	
	Zone 1: Wednesday	CAL1,CAL2, CAL3,CAL4	CAL1	
	Zone 1: Thursday	CAL1,CAL2, CAL3,CAL4	CAL1	
	Zone 1: Friday	CAL1,CAL2, CAL3,CAL4	CAL1	
	Zone 1: Saturday	CAL1,CAL2, CAL3,CAL4	CAL1	
	Zone 1: Sunday	CAL1,CAL2, CAL3,CAL4	CAL1	

Menu / Clock and programs

Menu item	Description	Range	Default	Customised value
Zone 2 Program	Zone 2 time scheduling (if present)	-	-	
	Zone 2: Monday	CAL1, CAL2, CAL3, CAL4	CAL1	
	Zone 2: Tuesday	CAL1, CAL2, CAL3, CAL4	CAL1	
	Zone 2: Wednesday	CAL1, CAL2, CAL3, CAL4	CAL1	
	Zone 2: Thursday	CAL1, CAL2, CAL3, CAL4	CAL1	
	Zone 2: Friday	CAL1, CAL2, CAL3, CAL4	CAL1	
	Zone 2: Saturday	CAL1, CAL2, CAL3, CAL4	CAL1	
	Zone 2: Sunday	CAL1, CAL2, CAL3, CAL4	CAL1	
Zone 3 Program	Zone 3 time scheduling (if present)	-	-	
	Zone 3: Monday	CAL1, CAL2, CAL3, CAL4	CAL1	
	Zone 3: Tuesday	CAL1, CAL2, CAL3, CAL4	CAL1	
	Zone 3: Wednesday	CAL1, CAL2, CAL3, CAL4	CAL1	
	Zone 3: Thursday	CAL1, CAL2, CAL3, CAL4	CAL1	
	Zone 3: Friday	CAL1, CAL2, CAL3, CAL4	CAL1	
	Zone 3: Saturday	CAL1, CAL2, CAL3, CAL4	CAL1	
	Zone 3: Sunday	CAL1, CAL2, CAL3, CAL4	CAL1	

INSTALLER

USER

MAINTENANCE TECHNICIAN

TECHNICAL DATA

Menu/ Clock and programs				
Menu item	Description	Range	Default	Customised value
DHW Program	DHW operation time programming	-	-	
	Domestic Hot Water: Monday	CAL1,CAL2, CAL3,CAL4	CAL1	
	Domestic Hot Water: Tuesday	CAL1,CAL2, CAL3,CAL4	CAL1	
	Domestic Hot Water: Wednesday	CAL1,CAL2, CAL3,CAL4	CAL1	
	Domestic Hot Water: Thursday	CAL1,CAL2, CAL3,CAL4	CAL1	
	Domestic Hot Water: Friday	CAL1,CAL2, CAL3,CAL4	CAL1	
	Domestic Hot Water: Saturday	CAL1,CAL2, CAL3,CAL4	CAL1	
	Domestic Hot Water: Sunday	CAL1,CAL2, CAL3,CAL4	CAL1	
Recirculation Program	Recirculation operation time programming	-	-	
	Recirculation: Monday	CAL1,CAL2, CAL3,CAL4	CAL1	
	Recirculation: Tuesday	CAL1,CAL2, CAL3,CAL4	CAL1	
	Recirculation: Wednesday	CAL1,CAL2, CAL3,CAL4	CAL1	
	Recirculation: Thursday	CAL1,CAL2, CAL3,CAL4	CAL1	
	Recirculation: Friday	CAL1,CAL2, CAL3,CAL4	CAL1	
	Recirculation: Saturday	CAL1,CAL2, CAL3,CAL4	CAL1	
	Recirculation: Sunday	CAL1,CAL2, CAL3,CAL4	CAL1	
Holiday Program	Defines the period during which the system disables both hot water heating and room central heating and/or cooling functions. At the end of the set days, the previously active functions will be reset.	Off / 1 day - 30 days	Off	

Menu/ User				
Menu item	Description	Range	Default	Customised value
Disable HP	It allows you to disable the heat pump according to the set time slot or via the outdoor contact.	Yes / No	No	
Start hourly HP disab.	Allows to set when disabling starts.	0-23h	0h	
End hourly HP disab.	Allows to set when disabling ends.	0-23h	0h	
Disable Integration	Allows the integration device to be permanently disabled.	Yes / No	No	
Enable func. Deaeration	Enables the de-aeration function.	Yes / No	No	
Screed heater		-	-	

Menu / User / Screed heater

Menu item	Description	Range	Default	Customised value
Min dwell time set	Defines the time spent at minimum operating temperature during the active function.	1 - 7 days	3 days	
Rise gradient	Defines the ascent gradient of the temperature	3 ÷ 30 °C/g	30 °C/g	
Max dwell time set	Defines the time spent at maximum operating temperature during the active function.	1 - 14 days	4 days	
Fall gradient	Defines the descent gradient of the temperature	3 ÷ 30 °C/g	30 °C/g	
Minimum flow set	Defines the minimum delivery temperature of the screed heater function	20 ÷ 45 °C	25 °C	
Maximum flow set	Defines the maximum delivery temperature of the screed heater function	25 ÷ 55 °C	45 °C	
Activation	Activation of the screed heater function	Yes / No	No	

Menu / Information

Menu item	Description
Heat pump	Defines the heat pump operating parameters.
Board revisions	This displays the system board revisions.
Meters	This displays the operating data.

Menu / Information / Heat pump

Menu item	Description
Flow temperature	Heat pump flow temperature
Return temperature	Heat pump return temperature
Compress.outlet temp.	Outdoor unit compressor temperature
Compress. drain temp.	Outdoor unit compressor discharge temperature
Compress.int.temp.	Not present
Expan.valve pos.	Outdoor unit expansion valve position
Heat exch.cool.temp.	Coolant temperature inside the plate heat exchanger
Coil temperature	Outdoor unit coil temperature
Outdoor HP temp.	External temperature
HP frequency	Heat pump frequency
HP request mode	Status of the request to heat pump
HP Status	Heat pump status
System resistance	System resistance active control
DHW resistance 1	Standard DHW (Domestic hot water) resistance active control
System state	Technical parameter (only for Immergas Assistance)
Integration state	Technical parameter (only for Immergas Assistance)
Output status	Technical parameter (only for Immergas Assistance)
DHW resistance 2	Manual ignition of the DHW (Domestic hot water) resistance 2
Disable HP	Heat pump activation/deactivation status
Inverter current	Outdoor unit inverter current

INSTALLER

USER

MAINTENANCE TECHNICIAN

TECHNICAL DATA

Menu / Information / Heat pump	
Menu item	Description
Fan speed (H)	Outdoor unit high fan speed
Fan speed (L)	Outdoor unit low fan speed
HP Setpoint	Request setpoint to heat pump
Pumpspeed	Heat pump circulator speed
System flow temp.	System temperature
Heat. set correc.	Current correction of the flow setpoint
System flow rate	Heat pump circuit flow rate
Photovoltaic	Operating status combined with a photovoltaic system
Power reduction	This displays a reduction of the PdC operating frequency
Hot/Cold three-way	Summer/Winter Three-way Position
Recirculation pump	Active recirculation pump
Interface board type	Communication board type
Screed heater end days	Days left until the end of the screed heater
Recirculation Temp.	DHW recirculation probe temperature
Information 1	Heat pump configuration code
Information 2	Flow temperature calculated after electrical resistance (multiplied by 10).
Information 3	Not used
Information 4	Not used
Information 5	Parameter for internal use

Menu / Information / Board revisions	
Menu item	Description
Display board rev. SW	Remote panel software revision
Display board rev. HW	Remote panel hardware revision
Supervis. board SW	Supervision board software revision
Supervis. board BIOS	Supervision board hardware revision
EU main board rev. no.	Outdoor unit main board firmware revision
EU main board rev. date	Outdoor unit main board firmware date
EU inverter rev. no.	Outdoor unit inverter board firmware revision
EU inverter rev. date	Outdoor unit inverter board firmware date
UE eeprom rev. no.	Outdoor unit EEPROM firmware revision
UE eeprom rev. data	Outdoor unit EEPROM firmware date
EU interface rev. no.	Communication board firmware revision
Expans. board rev. (H)	Revision of the expansion board (top part)
Expans. board rev. (L)	Revision of the expansion board (bottom part)

Menu / Information / Meters	
Menu item	Description
HP running hours	Number of hours of operation of the compressor
Resist. run hours Heating.	Hours of operating of the electrical resistance
Resist. run hours DHW1	Hours of operation of the standard DHW (Domestic hot water) resistance
Resist. run hours DHW2	Hours of operation of the optional DHW (Domestic hot water) resistance

Menu / Anomalies log	
Menu item	Description
Reset anomalies	Resets the list of anomalies
Anomalies log	

Menu / Anomalies log / Anomalies log	
Menu item	Description
History index	
Anomaly code	This displays the selected anomaly code
Technical anomaly	

Menu / General settings				
Menu item	Description	Range	Default	Customised value
Language	Defines the remote panel operation language	ITA - BUL - CZE - FRA - NLD - GER - ENG - GRE - LIT - POL - POR - RUM - RUS - SLO - SLV - SPA - HUN - UKR	ITA	
Display	It allows for various display adjustments.			
Access level	Allows the entry of an access code to access the parameter customisation menus according to ones needs (dedicated to a qualified technician)			

Menu / General settings / Display				
Menu item	Description	Range	Default	Customised value
Contrast	Allows to adjust the display contrast	Min / 2 ÷ 9 / Max	5	
Display lighting	Allows to set the display operation mode	Off / Min / Auto / Max	Auto	



The parameters referring to zone 2 can only be displayed if there is a zone 2 on the system and it is configured correctly.



The parameters referring to zone 3 can only be displayed if there is a zone 3 on the system and it is configured correctly.

2.7 FAULT AND ANOMALY SIGNALS

The indoor unit indicates a possible anomaly through a code flanked by the symbol of a key "  " in the centre of the display and the message "indoor unit anomaly" at the bottom of the display itself (Fig. 28).

If a fault is displayed, note down the code displayed in the centre of the display in addition to the phrase "indoor unit fault" or "outdoor unit fault" and report it to the technician authorised to carry out repairs and maintenance, if necessary. Some of these alarms are associated with a temporary event, in which case you can attempt to reset the system and the alarm by pressing the RESET button on the display.

Error Code	Anomaly signalled	Cause	Appliance status / Solution
5	Delivery probe fault	The board detects an anomaly on the flow NTC probe.	The system does not start (1).
8	Incorrect operation/ fault reset	Number of allowed resets already performed.	The anomaly can be reset 5 consecutive times, after which the function is inhibited for at least one hour and it is possible to try once every hour, for a maximum of 5 attempts. By switching the appliance on and off again, the 5 attempts are re-acquired
12	Storage tank probe anomaly	The board detects an anomaly on the storage tank probe	The hydronic module is unable to produce domestic hot water (1).
15	Configuration error	If the board detects an anomaly or incongruity on the electric wiring, the appliance will not start	If normal conditions are restored, the heat generator restarts without having to be reset (1).
23	Return probe anomaly	The board detects an anomaly on the return NTC probe	The system does not start (1).
24	Push button control panel anomaly	The board detects an anomaly on the pushbutton panel.	If normal conditions are restored, the system restarts without having to be reset (1).
26	Flowmeter anomaly	The board detects an anomaly on the flowmeter. Booster pump, if any, always working.	The system does not start (1). Make sure the booster pump (optional) only activates when requested.
27	Circulation insufficient	This happens when the hydronic module overheats due to poor water circulation in the primary circuit. The causes can be: - pdc pump blocked; free the pump; - damaged flowmeter.	Check system circulation and flowmeter. Press the Reset button (1).

(1) If the shutdown or fault persists, contact an authorised company (e.g. Authorised After-Sales Technical Assistance Centre).

Error Code	Anomaly signalled	Cause	Appliance status / Solution
32	Zone 2 Low Temperature probe anomaly	If the board detects an anomaly on the zone 2 low temperature probe, the system cannot work in the affected area.	(1)
33	Zone 3 low temperature probe anomaly	If the board detects an anomaly on the zone 3 low temperature probe; the system cannot work in the affected area.	(1)
34	Low-temperature Zone 2 safety thermostat intervention	During normal operation, if an anomaly causes excessive overheating of the flow temperature in the low temperature zone 2, the unit indicates the malfunction.	The unit does not meet the zone central heating requirement. (1)
35	Low-temperature zone 3 safety thermostat intervention	During normal operation, if an anomaly causes excessive overheating of the flow temperature in the low temperature zone 3, the unit indicates the malfunction.	The unit does not meet the zone central heating requirement. (1)
37	Low power supply voltage value	This occurs when the power supply voltage is lower than the allowed limits for correct system operation.	If normal conditions are restored, the system restarts without having to be reset (1)
50	External probe anomaly	In the event the external probe is not connected or is faulty, the anomaly is indicated.	Check the external probe connection. The system continues to operate with the external probe integrated in the external unit (1). In case of replacement of the external probe, repeat the installation operations.
55	Zone 1 temperature probe anomaly	The zone 1 flow probe has an out-of-range resistive value	(1)
104	Zone 3 off-line expansion alarm	The device connected to zone 3 is offline	(1)
120	Alarm set high for zone 1 dehumidification	The cooling flow set calculated for dehumidification is higher than the limit set in zone 1	The calculated flow set is higher than the limit allowed by the dehumidifier. Cool the room and wait for the dew temperature to go back within acceptable values (1).
121	Zone 1 offline device alarm	The device connected to zone 1 is offline	(1)

(1) If the shutdown or fault persists, contact an authorised company (e.g. Authorised After-Sales Technical Assistance Centre).

INSTALLER

USER

MAINTENANCE TECHNICIAN

TECHNICAL DATA

Error Code	Anomaly signalled	Cause	Appliance status / Solution
123	Zone 3 offline device alarm	The device connected to zone 3 is offline.	(1)
125	Zone 1 room temperature probe error	The zone 1 room probe has an out of range resistive value	(1)
126	Zone 2 room temperature probe error	The zone 2 room probe has an out of range resistive value	(1)
127	Zone 3 room temperature probe error	The zone 3 room probe has an out of range resistive value.	(1)
129	Zone 1 humidity probe error	Anomaly on the zone 1 humidity probe.	In addition to the humidity, the dew point is not calculated for the zone either (1). Zone humidity cannot be checked.
130	Zone 2 humidity probe error	Anomaly on the zone 2 humidity probe.	In addition to the humidity, the dew point is not calculated for the zone either (1). Zone humidity cannot be checked.
131	Zone 3 humidity probe error	Anomaly on the zone 3 humidity probe.	In addition to the humidity, the dew point is not calculated for the zone either (1). Zone humidity cannot be checked.
132	Alarm set high for zone 2 dehumidification	The cooling flow set calculated for dehumidification is higher than the limit set in zone 2	The calculated flow set exceeds the limit permitted by the dehumidifier. Cool the room and wait for the dew temperature to go back within acceptable values (1).
133	Zone 1 dehumidifier fault alarm	Anomaly coming from the dehumidifier (optional) on zone 1	The system does not dehumidify in the relative zone (1)
(1) If the shutdown or fault persists, contact an authorised company (e.g. Authorised After-Sales Technical Assistance Centre).			

Error Code	Anomaly signalled	Cause	Appliance status / Solution
134	Zone 2 dehumidifier fault alarm	Anomaly coming from the dehumidifier (optional) in zone 2	The system does not dehumidify in the relative zone (1)
135	Zone 3 dehumidifier fault alarm	Anomaly coming from the dehumidifier (optional) on zone 3	The system does not dehumidify in the relative zone (1)
136	High set alarm for dehumidification-zone 3	The cooling flow set calculated for dehumidification exceeds the limit set in zone 3	The calculated flow set is higher than the limit allowed by the dehumidifier. Cool the room and wait for the dew temperature to go back within acceptable values (1).
137	Reset system alarm – Restart the system	When the default parameters are restored, the system needs to be restarted.	Turn the system off and on.
139	De-aeration in progress	Deaeration function in progress	No demand can be made until the end of the function in progress (1)
142	Errore Dominus offline	Communication with Dominus is offline	(1)
143	Recirculation probe alarm	The board detects an anomaly on the D.H.W. recirculation probe	The system does not recirculate DHW (1)
177	DHW maximum time alarm	Domestic hot water production is not met within the pre-established time (see parameter P014)	The system continues to operate with non-optimal performance (1)
178	Block: anti-legionella cycle not successful	The anti-Legionella cycle is run without success within the pre-established time (see parameter P013)	Press the Reset button (1)
179	Liquid phase probe alarm	The board detects an anomaly on the liquid phase NTC probe.	The system does not start (1).

INSTALLER

USER

MAINTENANCE TECHNICIAN

TECHNICAL DATA

Error Code	Anomaly signalled	Cause	Appliance status / Solution
183	Outdoor unit in test mode	A signal notifies that the outdoor unit is in test mode.	During this time, room air conditioning and domestic hot water production requirements cannot be met
188	Request out of operating range	A request is made with the outdoor temperature exceeding the operating limits (Parag. 1.17)	The system does not start (1). Wait for the outdoor unit to be restored within operating limits.
189	Time out alarm with communication board	If communication between the printed circuit boards is lost, an anomaly is signalled.	The system does not start (1). Check communication between the P.C.B. and the interface board.
195	Alarm low liquid phase probe temperature	Too low temperature is detected in the liquid phase	Check that the cooling circuit is working properly (1).
196	High flow temp. block	An excessively high temperature is detected on the heat pump flow circuit	Check the hydraulic circuit (1).
197	Communication board configuration error	An incorrect communication board configuration has been detected	The system does not start (1).

(1) If the shutdown or fault persists, contact an authorised company (e.g. Authorised After-Sales Technical Assistance Centre).

List of outdoor unit anomalies

If the outdoor unit is faulty, the error code is displayed in the middle of the control panel (Fig. 28) with a key symbol next to it "  ". In addition, the message "Outdoor condensing unit anomaly" is displayed at the bottom of the display (Fig. 28).

If a fault is displayed, note down the code displayed in the centre of the display in addition to the phrase "indoor unit fault" or "outdoor unit fault" and report it to the technician authorised to carry out repairs and maintenance, if necessary. Alarms from the outdoor unit cannot be reset using the RESET button on the display. In this case you must first disconnect power to the outdoor unit, wait a few minutes, restore it and press the RESET button on the display.

Error Code	Anomaly signalled	Hydronic module status/ Solution
101	Outdoor unit communication error	Check the communication cable to the outdoor unit. Check that the interface board works properly. (1)
109	Communication error due to incorrect address of interface board	Check the address on the interface board. (1)
111	MODBUS communication error	Check communication between the management board and interface boards. (1)
162	EEPROM error	Replace the main board of the outdoor unit (1)
177	Emergency error	(1)
198	Error of thermal fuse terminal board (open)	(1)
201	Communication error (failed coupling) between interface board and outdoor unit	Check the communication cable to the outdoor unit. Check that the interface board and main board of the outdoor unit work properly (1)
202	Communication error (failed coupling) between indoor unit and interface board	Check the communication cable to the outdoor unit. Check that the interface board and main board of the outdoor unit work properly (1)
203	Communication error between Inverter and main board of the outdoor unit	Check wiring of communication between the two boards. Replace the main board. Replace the inverter board (1)
(1) If the shutdown or fault persists, contact an authorised company (e.g. Authorised After-Sales Technical Assistance Centre).		

INSTALLER

USER

MAINTENANCE TECHNICIAN

TECHNICAL DATA

Error Code	Anomaly signalled	Hydronic module status/ Solution
221	Outdoor unit air temperature sensor error	Check the position of the sensor. Check the relative wiring Replace the sensor (1)
231	Condenser temperature sensor error	Check the position of the sensor. Check the relative wiring Replace the sensor (1)
251	Discharge temperature sensor error	Check the position of the sensor. Check the relative wiring Replace the sensor
320	Compressor sensor error (overload protection sensor)	Check the position of the sensor. Check the relative wiring Replace the sensor (1)
403	Freezing detection (during cooling operation)	Check the chiller cycle. Check the temperatures of the plate heat exchanger (1)
404	Protection of outdoor unit when in overload (during safety start-up, normal operating status)	Check the chiller cycle. Check the compressor connections. Check the resistances between the different phases of the compressor (1)
407	Compressor not working due to high pressure	Check the chiller cycle (1)
416	The compressor discharge is overheated	(1)
419	Outdoor unit EEV operation error	(1)
425	Not used on this model	(1)
440	Central heating blocked (outdoor temperature beyond 35°C)	(1)
441	Cooling blocked (outdoor temperature below 9°C)	(1)
458	Error of outdoor unit fan no.1	(1)
(1) If the shutdown or fault persists, contact an authorised company (e.g. Authorised After-Sales Technical Assistance Centre).		

Error Code	Anomaly signalled	Hydronic module status/ Solution
461	Compressor start-up error (Inverter)	Check the chiller cycle. Check the compressor connections. Check the resistances between the different phases of the compressor (1)
462	Inverter total current overload error	Check the inlet current. Check the refrigerant charge. Check normal operation of the fan. (1)
463	Compressor overheated sensor	Check the compressor sensor. (1)
464	Inverter IPM current overload error	Check the compressor connections and its normal operation. Check the refrigerant charge. Check whether there are obstacles around the outdoor unit. Check whether the service valve is open. Check whether the installation pipes are mounted properly. (1)
465	Compressor overload error	Check the compressor connections and its normal operation. Check the resistances between the different phases of the compressor. (1)
466	Low voltage error of DC circuit	Check the input voltage. Check the power connections. (1)
467	Compressor rotation error	Check the compressor connections. Check the resistances between the different phases of the compressor. (1)
468	Current sensor error (inverter)	Check the main board. (1)
469	Voltage sensor error of DC circuit (inverter)	Check the power connector of the inverter board. Check the connectors RY21 and R200 of the inverter board. (1)
(1) If the shutdown or fault persists, contact an authorised company (e.g. Authorised After-Sales Technical Assistance Centre).		

INSTALLER

USER

MAINTENANCE TECHNICIAN

TECHNICAL DATA

Error Code	Anomaly signalled	Hydronic module status/ Solution
470	EEPROM reading/writing error of outdoor unit	Check the main board. (1)
471	EEPROM reading/writing error of outdoor unit	Check the main board. (1)
474	Inverter temperature sensor error	Replace inverter board (1)
475	Error of outdoor unit fan no.2 (where present)	Check the wiring. Check that the fan is powered. Check the board fuses. (1)
484	PFC overload	Check inductances. Replace inverter board. (1)
485	Incoming current sensor error	Replace inverter board. (1)
500	IPM overheated	Check temperature of inverter board. Switch the machine off. Wait for the inverter to cool down. Switch the machine back on. (1)
554	Coolant gas leak error	Check that the coolant is charged Check the liquid sensor of the indoor unit Check whether the service valve is open Check whether the installation pipes are mounted properly. (1)
590	Inverter board error	Check normal operation of the main board. Replace the main board (1)
601	Not present	(1)
604	Not present	(1)
653	Not present	(1)
654	Not present	(1)

(1) If the shutdown or fault persists, contact an authorised company (e.g. Authorised After-Sales Technical Assistance Centre).

Error Code	Anomaly signalled	Hydronic module status/Solution
899	Not present	(1)
900	Not present	(1)
901	Not used	Indoor unit error Check indoor unit (1)
902	Not used	Indoor unit error Check indoor unit (1)
903	Not used	Indoor unit error Check indoor unit (1)
904	Not used	Indoor unit error Check indoor unit (1)
906	Not used	Indoor unit error Check indoor unit (1)
911	Not used	Indoor unit error Check indoor unit (1)
912	Not used	Indoor unit error Check indoor unit (1)
916	Not used	Indoor unit error Check indoor unit (1)
919	Not used	Indoor unit error Check indoor unit (1)
(1) If the shutdown or fault persists, contact an authorised company (e.g. Authorised After-Sales Technical Assistance Centre).		

INSTALLER

USER

MAINTENANCE TECHNICIAN

TECHNICAL DATA

2.8 RESTORE CENTRAL HEATING SYSTEM PRESSURE

1. Periodically check the system water pressure (the Indoor Unit's pressure gauge hand must indicate a value between 1 and 1.2 bar).
2. If the pressure falls below 1 bar (when the system is cold) restore normal pressure via the relevant cock located to the right of the generator and accessible from the side door (Fig. 34).
3. Close the valve after the operation.
4. If the pressure reaches values around 3 bar, there is a risk of tripping the safety valve (in this case, remove water from a radiator air vent valve until a pressure of 1 bar is achieved, or ask for assistance from professionally qualified personnel).
5. In the event of frequent pressure drops, contact qualified staff for assistance to eliminate the possible system leakage.

2.9 DRAINING THE SYSTEM

1. Ensure that the filling valve is closed.
2. Open the draining valve (Par.1.22).
3. Open all vent valves.
4. At the end, close the draining valve.
5. Close all previously opened vent valves.



If fluid containing glycol was added to the system circuit, make sure it is recovered and disposed of in accordance with standard EN 1717.

2.10 EMPTYING THE D.H.W. CIRCUIT

To do this, always close the domestic cold water inlet upstream of the appliance.
Open any domestic hot water tap to discharge the pressure from the circuit.

2.11 STORAGE TANK DRAINING

To drain the storage tank, use the relevant storage tank draining valve (Det. 2, Fig. 27).



Before performing this operation, close the cold water inlet tap (Det. 3, Fig. 34) and open any hot water tap of the domestic hot water system to let air into the storage tank.

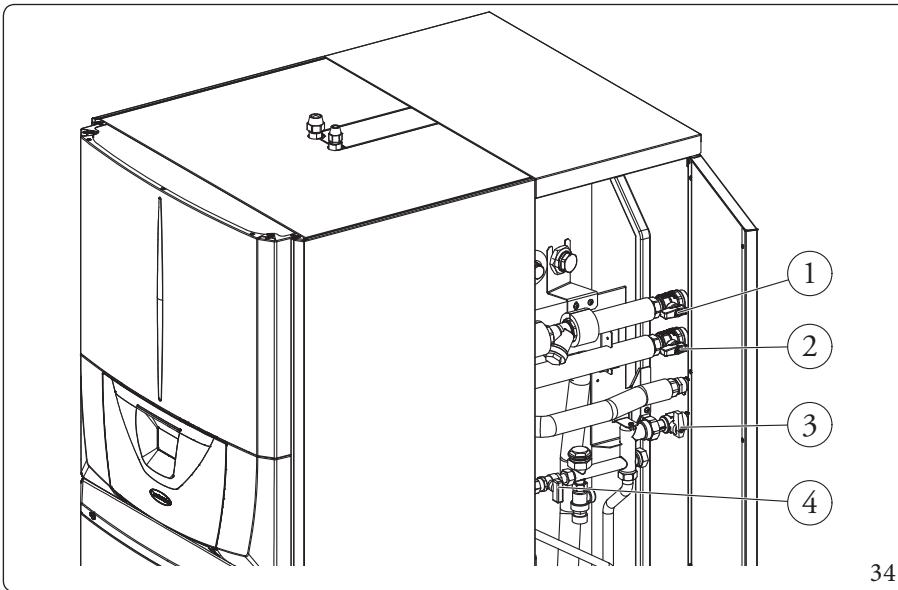

Key (Fig. 34):

- 1 - System return valve
- 2 - System flow valve
- 3 - Cold water inlet valve
- 4 - System filling valve

2.12 CLEANING THE CASE

1. Use damp cloths and neutral detergent to clean the Indoor Unit casing.



Never use abrasive or powder detergents.

2.13 PERMANENT SHUTDOWN

Should the system be shut down permanently, have professional staff carry out the procedures, making sure that the electrical and water supply lines have been previously shut off.

3 INSTRUCTIONS FOR MAINTENANCE AND INITIAL CHECK

3.1 GENERAL RECOMMENDATIONS

INSTALLER



Operators who install and service the appliance must wear the personal protective equipment (PPE) required by applicable law.
The list of possible PPE is not complete as they are indicated by the employer.

USER



Before carrying out any maintenance work, make sure that:

- you have disconnected the power to the appliance;
- you have discharged the pressure from the system and domestic hot water circuit.



Supply of spare parts

The device's warranty shall be rendered null and void if unapproved or unsuitable parts are used for maintenance or repairs. These will also compromise the product's compliance, and the said product may no longer be valid and fail to meet the current regulations. In regard to the above, only use original Immergas spare parts when replacing components.



If additional documentation needs to be consulted for extraordinary maintenance, contact the Authorised After-Sales Service.

MAINTENANCE TECHNICIAN



The appliance operates with R32 refrigerant gas.
This gas is ODOURLESS.

Pay the utmost attention

Strictly follow the instruction handbook of the Outdoor Unit before installation and any type of operation on the chiller line.



R32 refrigerant gas belongs to the low flammability refrigerant category: class A2L according to standard ISO 817. It guarantees high performance with low environmental impact. The new gas reduces the potential environmental impact by one third compared to R410A, having less effect on global warming (GWP 675).

TECHNICAL DATA

3.2 INITIAL CHECK

To commission the package, you must:

- Check connection to a 230V~50Hz power mains, correct L-N polarity and the earthing connection;
- make sure the central heating system is filled with water and the indoor unit pressure gauge reads a pressure of 1-1.2 bar;
- make sure the chiller circuit has been filled according to what is described in the outdoor unit instructions booklet;
- check the activation of the main switch located upstream of the indoor unit;
- ensure activation of all adjustment devices;
- ensure production of domestic hot water;
- check the tightness of the hydraulic circuits;



Even if just one single safety check provides a negative result, do not commission the system.

3.3 YEARLY APPLIANCE CHECK AND MAINTENANCE



The following checks and maintenance should be performed once a year to ensure operation, safety and efficiency of the appliance over time.

- Check for water leaks or oxidation from/on the fittings.
- Check, after discharging the system pressure and bringing it to zero (read on Indoor Unit pressure gauge), that the expansion vessel charge is at 1.0 bar.
- Check that the system static pressure (with system cold and after refilling the system by means of the filling valve) is between 1 and 1.2 bar.
- Visually check that the safety and control devices have not been tampered with and/or short-circuited.
- Check the condition and integrity of the electrical system and in particular:
 - the power supply wires must be housed in the cable glands;
 - there must be no traces of blackening or burning.
- Check correct lighting and operation.
- Check correct operation of control and adjustment devices and in particular:
 - system regulation probes intervention.
- Check chiller line connections.
- Check mesh filter on system return.
- Check the correct flow rate on plate heat exchanger.
- Check the integrity of the internal insulation.



In addition to yearly maintenance, one must also check the energy efficiency of the thermal system, with frequency and procedures that comply with the indications of the technical regulations in force.

3.4 FINNED AIR COIL MAINTENANCE



We recommend regularly inspecting the finned air coils to check the level of fouling.

INSTALLER

This depends on the environment where the unit is installed.

The level of fouling will be worse in urban and industrial sites, as well as near trees that lose their leaves.

There are two maintenance levels to clean the coils:

- If the air heat exchangers are encrusted, clean them gently with a brush in a vertical direction.
- Turn off the fans before working on the air heat exchangers.
- To perform this type of intervention, stop the unit only if the maintenance considerations allow it.
- Perfectly clean air heat exchangers ensure an optimal operation of the unit. When the air heat exchangers begin to encrust, they must be cleaned. The cleaning frequency depends on the season and location of the unit (ventilated, wooded, dusty, etc.).
- Do not use pressurised water without a large diffuser. Do not use high-pressure cleaners for Cu/Cu and Cu/Al air coils.
- Concentrated and/or rotating water jets are strictly prohibited. Never use fluid with a temperature above 45°C to clean the air heat exchangers.
- Proper and frequent cleaning (approx. every three months) prevents 2/3 of corrosion problems.

Clean the air coil using suitable products.

USER

MAINTENANCE TECHNICIAN

TECHNICAL DATA

3.5 HYDRAULIC DIAGRAM

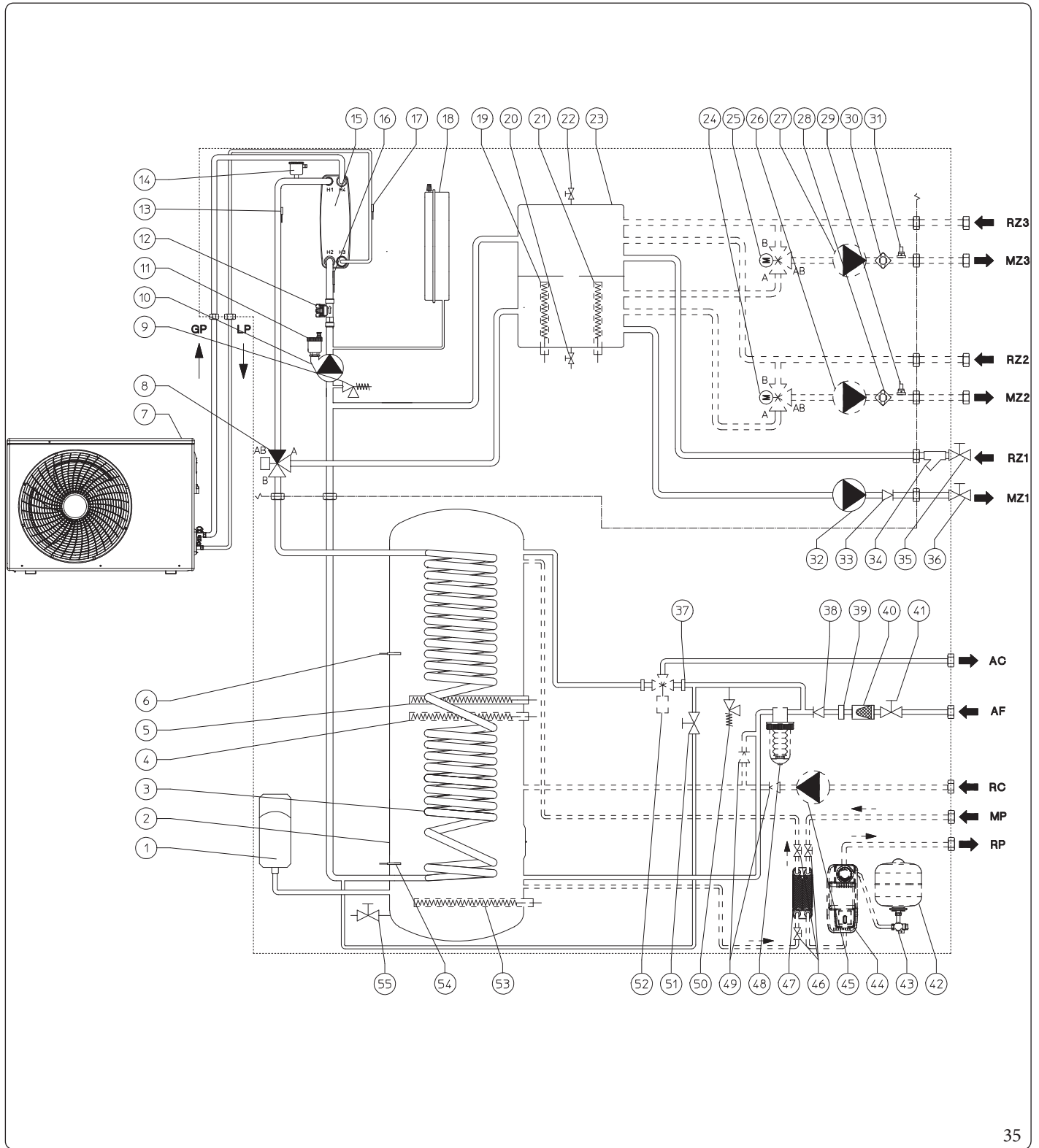

INSTALLER

USER

MAINTENANCE TECHNICIAN

TECHNICAL DATA

Key (Fig. 35):

- | | | | |
|----|--|-----|--|
| 1 | - Domestic hot water expansion vessel | RZ1 | - Direct zone 1 system return |
| 2 | - Stainless steel storage tank | MZ1 | - Direct zone 1 system flow |
| 3 | - Stainless steel coil for storage tank | RZ2 | - Direct zone 2 system return (Optional) |
| 4 | - DHW electrical resistance (Optional) | MZ2 | - Direct zone 2 system flow (Optional) |
| 5 | - DHW electrical resistance | RZ3 | - Direct zone 3 system return (Optional) |
| 6 | - D.H.W. probe | MZ3 | - Direct zone 3 system flow (Optional) |
| 7 | - Outdoor unit | AC | - Domestic hot water outlet |
| 8 | - Central heating / C.H. / cooling 3-way valve (motorised) | AF | - Domestic cold water inlet |
| 9 | - 3 bar safety valve | RC | - Pump (optional) |
| 10 | - Heat pump circulator | MP | - Flow from solar panels (optional) |
| 11 | - Air vent valve | RP | - Return to solar panels (optional) |
| 12 | - System flow-meter | GP | - Chiller line - gaseous phase |
| 13 | - Heat pump flow probe | LP | - Chiller line - liquid phase |
| 14 | - Air vent valve | | |
| 15 | - Plate heat exchanger | | |
| 16 | - Heat pump return probe | | |
| 17 | - Liquid phase detection probe | | |
| 18 | - System expansion vessel | | |
| 19 | - System electrical resistance (Optional) | | |
| 20 | - System draining valve | | |
| 21 | - System electrical resistance (Optional) | | |
| 22 | - Hydraulic manifold manual air vent valve | | |
| 23 | - Hydraulic manifold | | |
| 24 | - Zone 2 mixing valve (Optional) | | |
| 25 | - Zone 3 mixing valve (Optional) | | |
| 26 | - Zone 2 circulator (Optional) | | |
| 27 | - Zone 3 circulator pump (Optional) | | |
| 28 | - Zone 2 safety thermostat (Optional) | | |
| 29 | - Zone 2 low-temperature flow probe (Optional) | | |
| 30 | - Zone 3 safety thermostat (Optional) | | |
| 31 | - Zone 3 low-temperature flow probe (Optional) | | |
| 32 | - Direct zone 1 circulator | | |
| 33 | - One-way valve | | |
| 34 | - Filter that can be inspected | | |
| 35 | - System return shut-off valve | | |
| 36 | - System flow shut-off valve | | |
| 37 | - Cap for solar kit installation | | |
| 38 | - Cold water inlet non-return valve | | |
| 39 | - Flow limiter | | |
| 40 | - Cold water filter | | |
| 41 | - Cold water inlet valve | | |
| 42 | - Solar expansion vessel (Optional) | | |
| 43 | - Shut-off valve with solar system thermometer (Optional) | | |
| 44 | - Single solar circulation unit (Optional) | | |
| 45 | - DHW recirculation pump (Optional) | | |
| 46 | - Solar shut-off valves (Optional) | | |
| 47 | - Solar system plate heat exchanger (Optional) | | |
| 48 | - Polyphosphate dispenser (Optional) | | |
| 49 | - DHW recirculation one-way valve (Optional) | | |
| 50 | - 8 bar safety valve | | |
| 51 | - System filling valve | | |
| 52 | - Solar system DHW mixing valve (Optional) | | |
| 53 | - DHW electrical resistance (Optional) | | |
| 54 | - Storage tank solar probe (Optional) | | |
| 55 | - Storage tank draining valve | | |

3.6 WIRING DIAGRAM

Electrical board wiring diagram

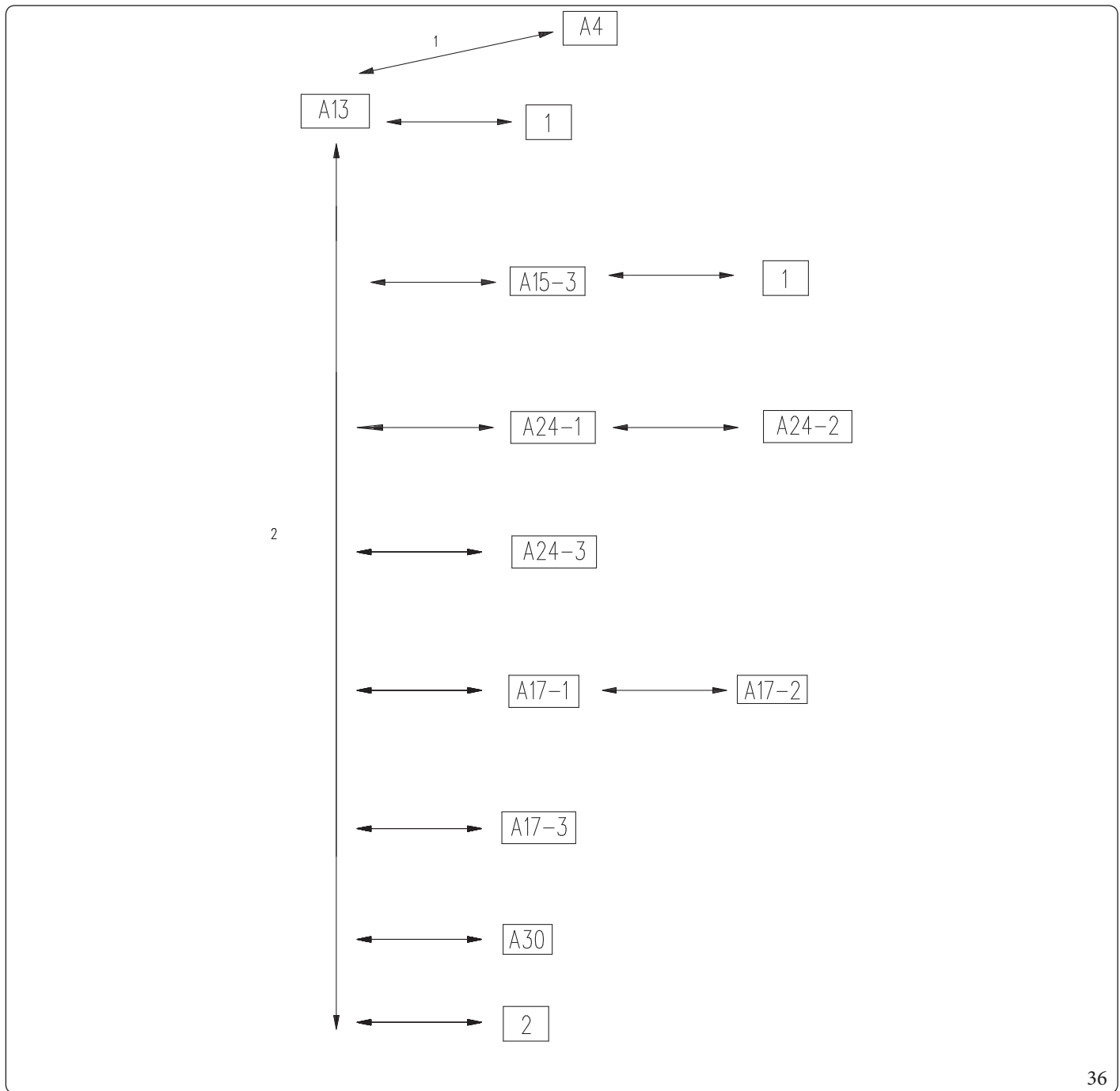

Key (Fig. 36):

- A4 - Display board
- A13 - System supervision board
- A15-3 - Zone 3 expansion board (optional)
- A24-1 - Zone 1 remote panel (optional)
- A24-2 - Zone 2 remote panel (optional)
- A24-3 - Zone 3 remote panel (optional)

- A17-1 - Zone 1 temperature/humidity sensor (optional)
- A17-2 - Zone 2 temperature/humidity sensor (optional)
- A17-3 - Zone 3 temperature/humidity sensor (optional)
- A30 - Dominus (optional)
- 1 - Electrical connections terminals
- 2 - Audax Pro V2

36

INSTALLER

USER

MAINTENANCE/TECHNICIAN

TECHNICAL DATA

INSTALLER

USER

MAINTENANCE TECHNICIAN

TECHNICAL DATA

X109 Terminal board connections diagram

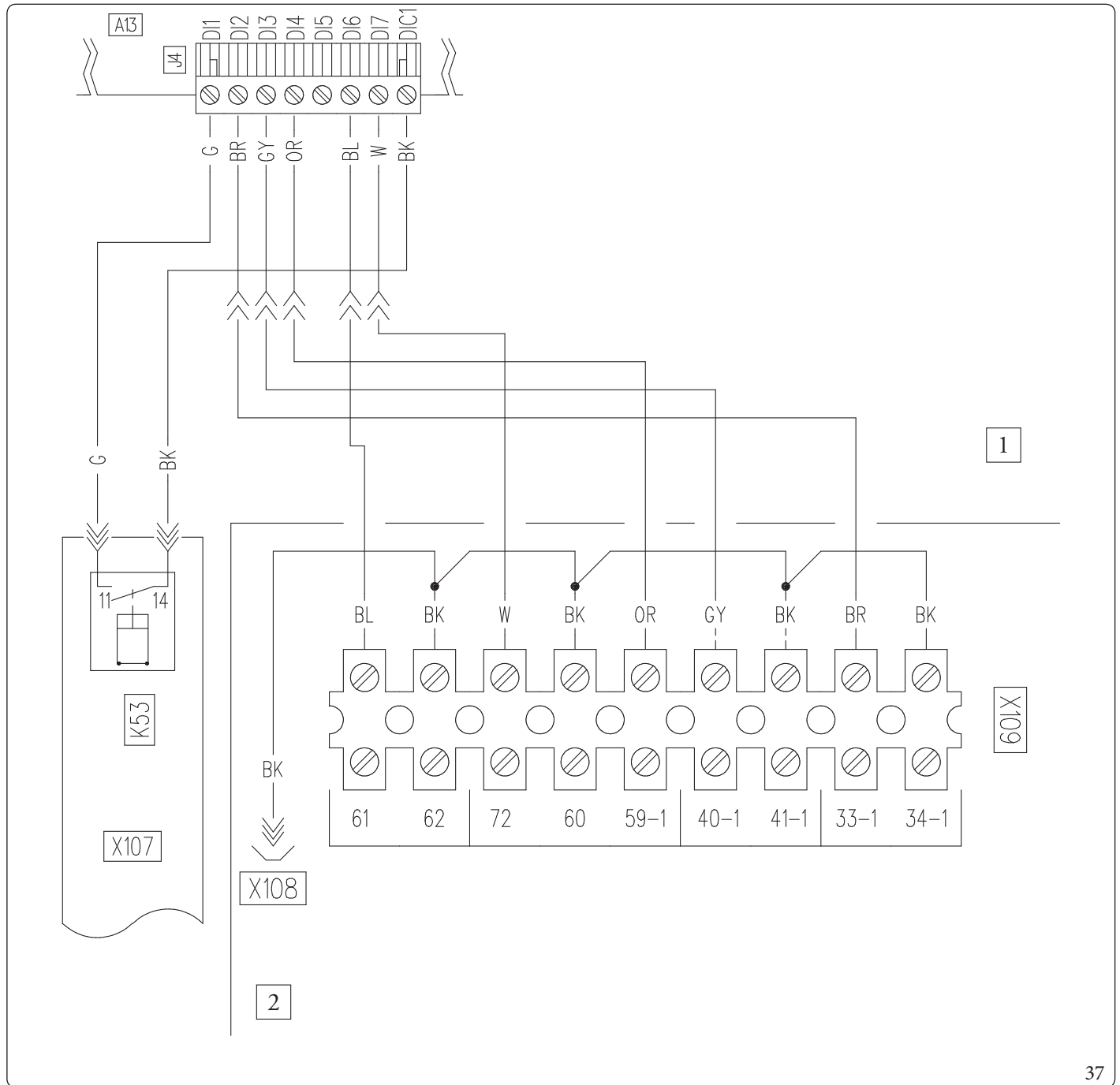

Key (Fig. 37):

- A13 - Supervision board
- K53 - Flowmeter Signal conversion relay

- 1 - Main panel
- 2 - Control panel

- BK - Black
- BL - Blue
- W - White
- OR - Orange
- GY - Grey
- BR - Brown
- G - Green

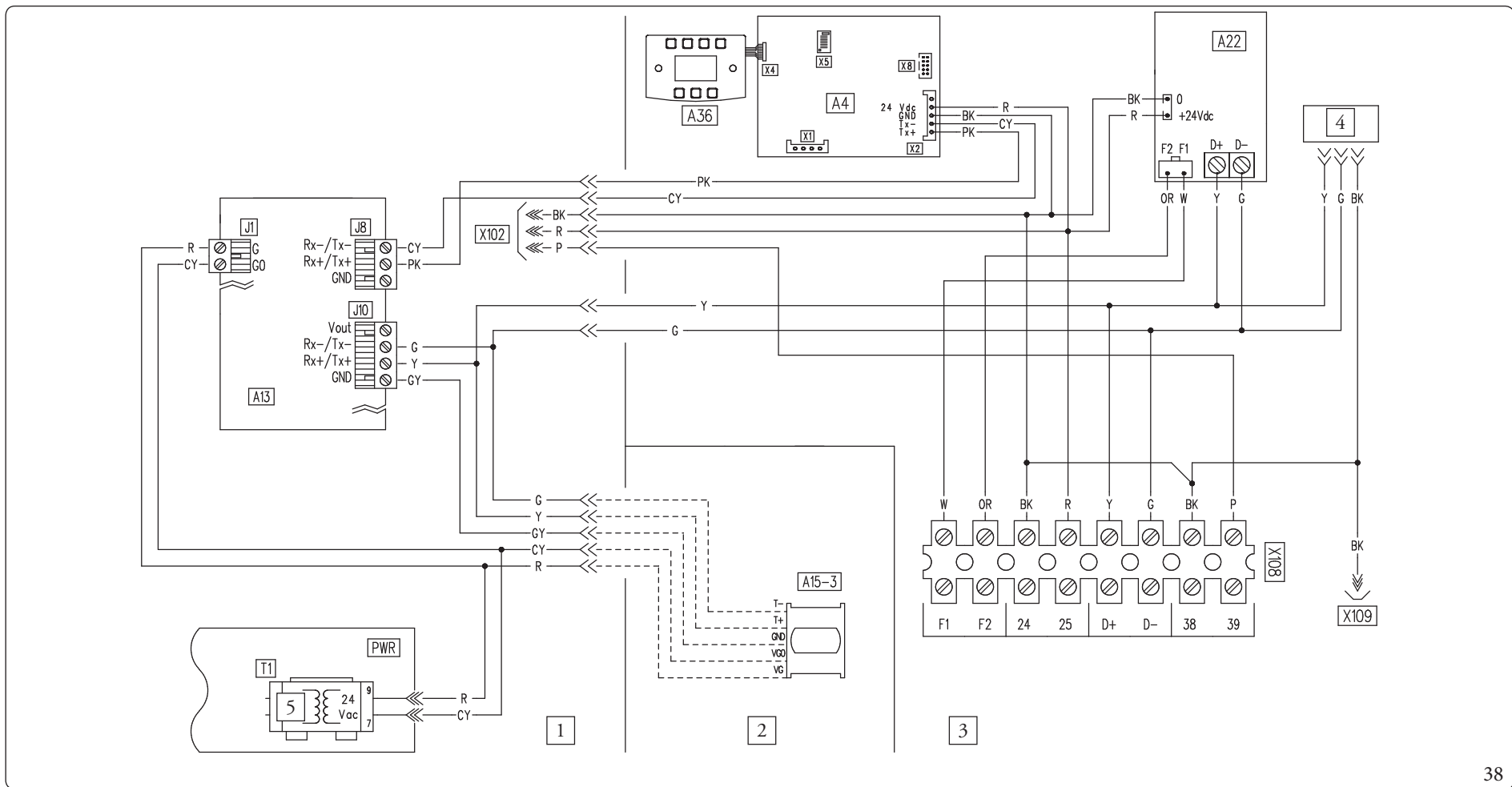

38

Key (Fig. 38):

- A4 - Displayboard
- A13 - Supervision board
- A15-3 - Zone 3 expansion (optional)
- A22 - Condensing unit interface board
- A36 - Touch keyboard
- T1 - Transformer

- 1 - Main panel
- 2 - Optional kit panel
- 3 - Control panel
- 4 - Test connector
- 5 - 230 Vac

- BK - Black
- W - White
- OR - Orange
- GY - Grey
- G - Green
- PK - Pink
- R - Red
- P - Purple
- Y - Yellow
- CY - Cyan

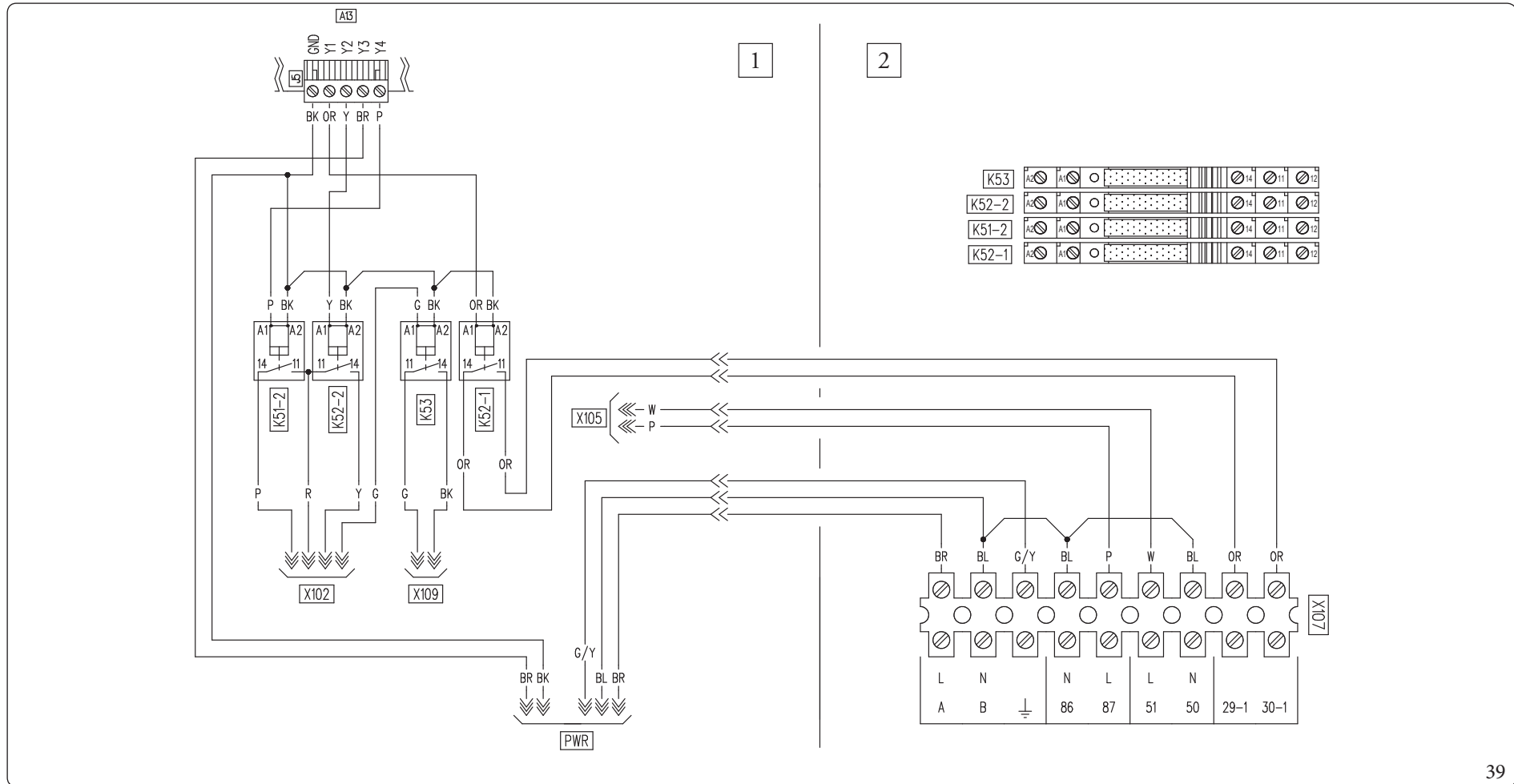

Key (Fig. 39):

- A13 - Supervision board
- K51-2 - Zone 2 air conditioning control relay
- K52-1 - Zone 1 dehumidification control relay
- K52-2 - Zone 2 dehumidification control relay
- K53 - Flowmeter Signal conversion relay

- 1 - Main panel
- 2 - Control panel

- BK - Black
- W - White
- OR - Orange
- G - Green
- P - Purple
- Y - Yellow
- R - Red
- BL - Blue
- BR - Brown
- G/Y - Yellow/Green

X105 Terminalboard connections diagram

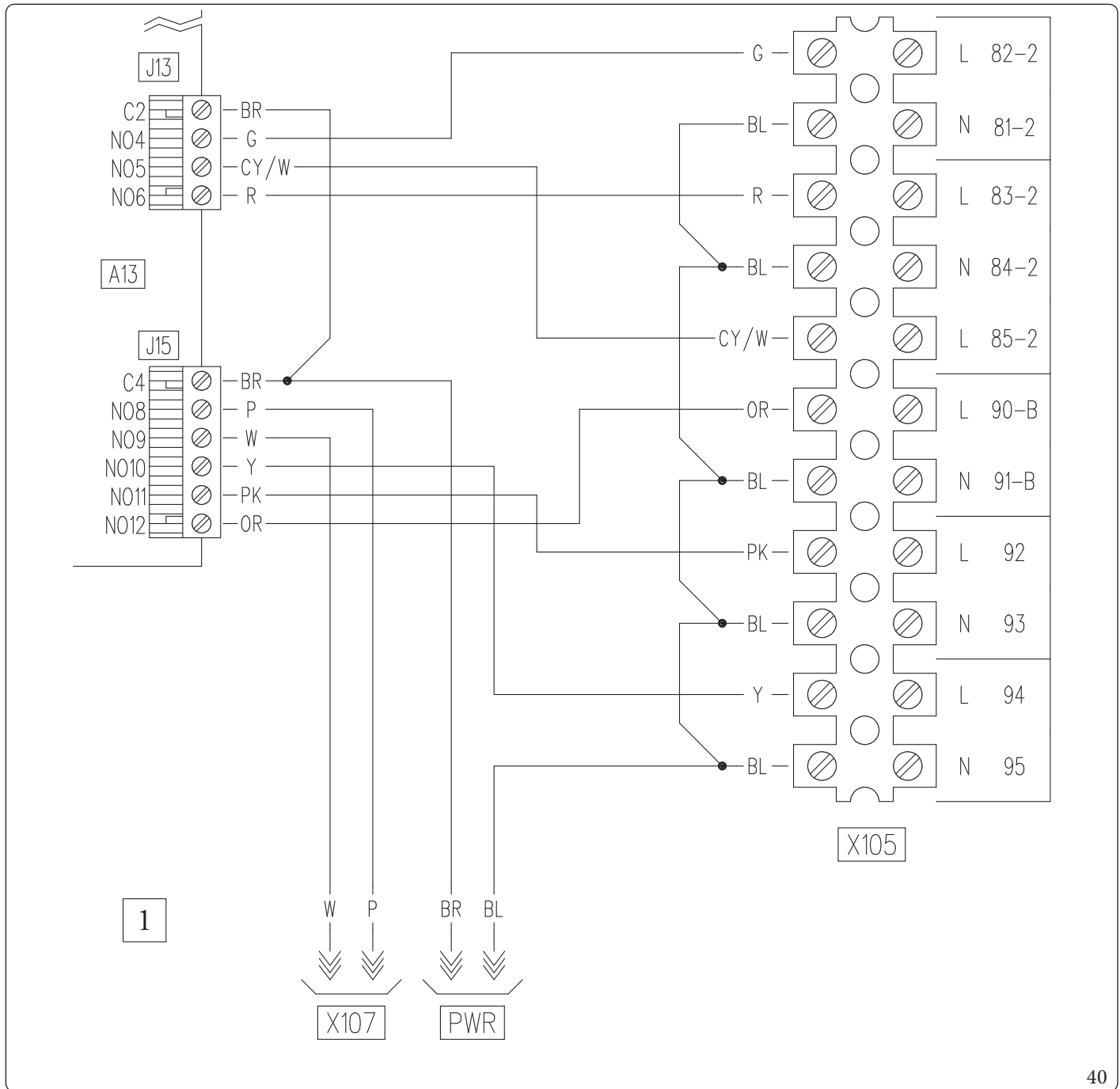

40

Key (Fig. 40):

A13 - Supervision board

1 - Main panel

W - White
 OR - Orange
 G - Green
 P - Purple
 Y - Yellow
 R - Red
 BL - Blue
 BR - Brown
 CY/W - Cyan/White
 PK - Pink

INSTALLER

USER

MAINTENANCE/TECHNICIAN

TECHNICAL DATA

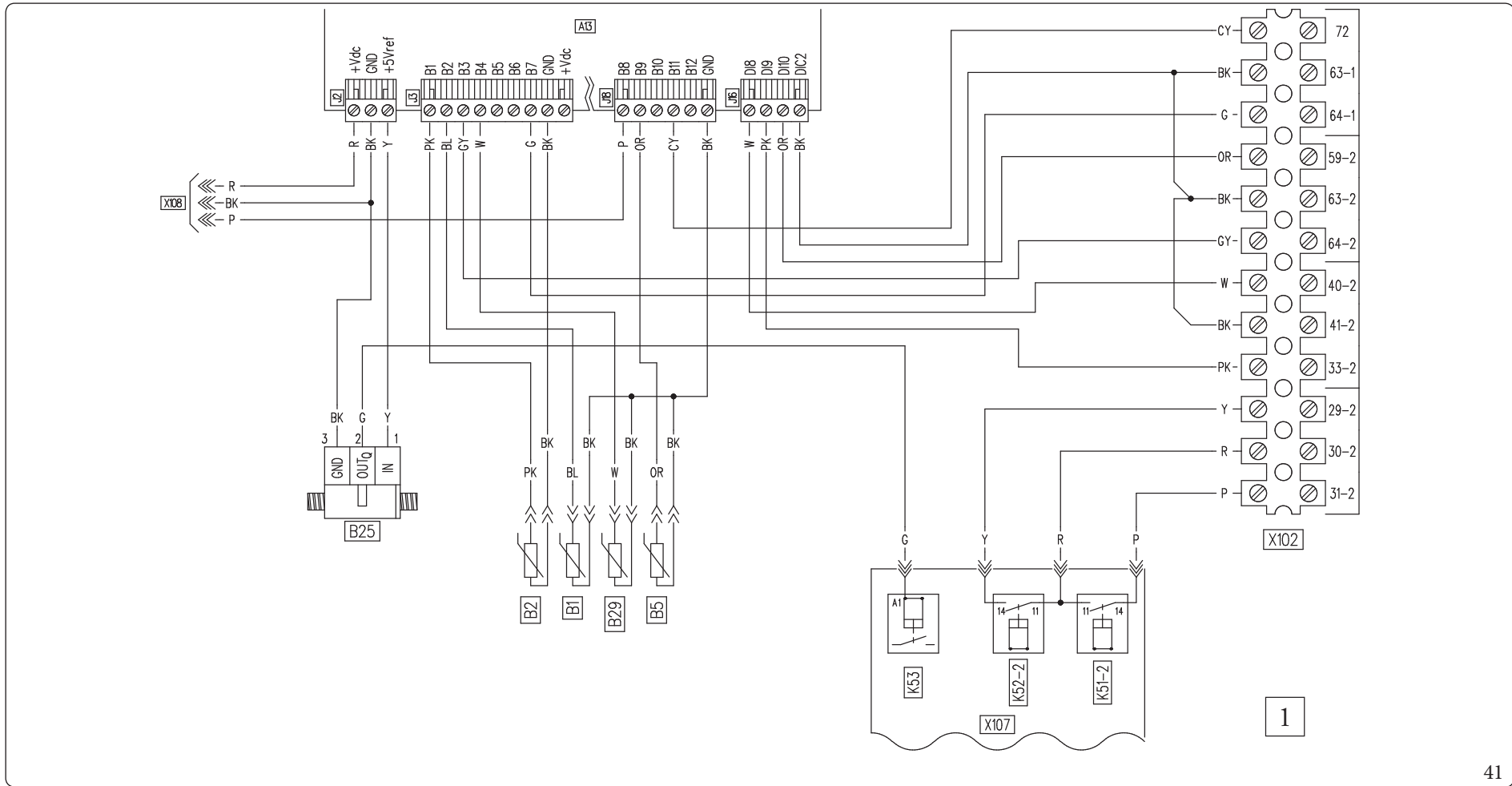

Key (Fig. 41):

- A13 - Supervision board
- B1 - Flow probe
- B2 - D.H.W. probe
- B5 - Return probe
- B25 - System flow-meter
- B29 - Liquid phase probe
- K51-2 - Zone 2 air conditioning control relay
- K52-2 - Zone 2 dehumidification control relay
- K53 - Flow meter signal conversion relay

- 1 - Main panel
- W - White
- OR - Orange
- G - Green
- P - Purple
- Y - Yellow
- R - Red
- BL - Blue
- BR - Brown

- CY - Cyan
- PK - Pink
- BK - Black
- GY - Grey

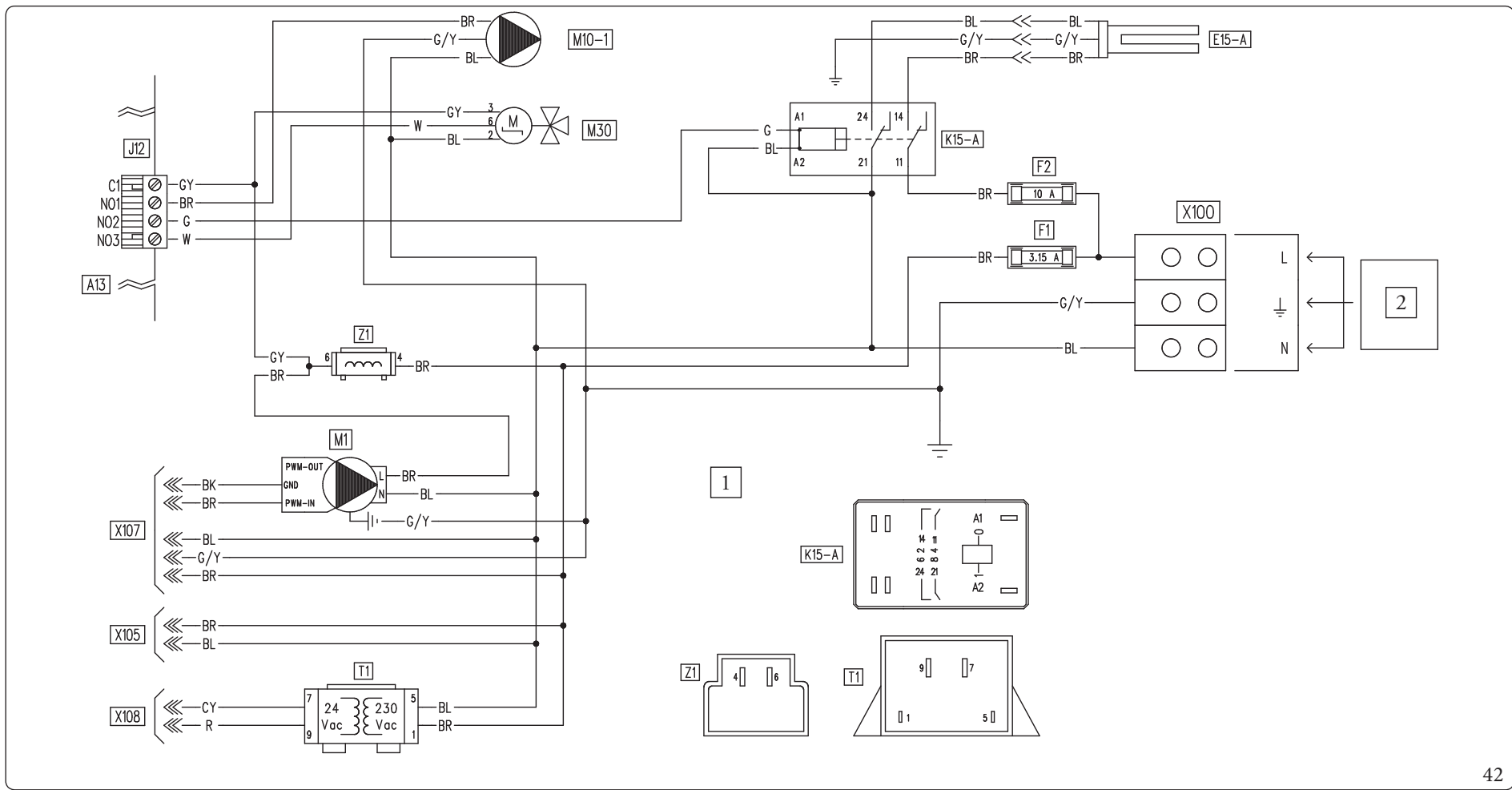

Key (Fig. 42):

- A13 - Supervision board
- E15-A - Domestic hot water integration resistance
- F1 - Control Phase fuse
- F2 - Resistance Phase fuse
- K15-A - DHW integrative resistance relay
- M1 - Heat pump circulator
- M10-1 - Zone 1 circulator pump
- M30 - DHW (Domestic hot water) diverter
- T1 - Transformer
- Z1 - Antijamming filter

- 1 - Main panel
- 2 - 230 Vac, 50 Hz, 3 kW, 1.5 mm²

- G - Green
- R - Red
- BL - Blue
- BR - Brown
- CY - Cyan
- BK - Black
- GY - Grey
- W - White
- G/Y - Yellow/Green

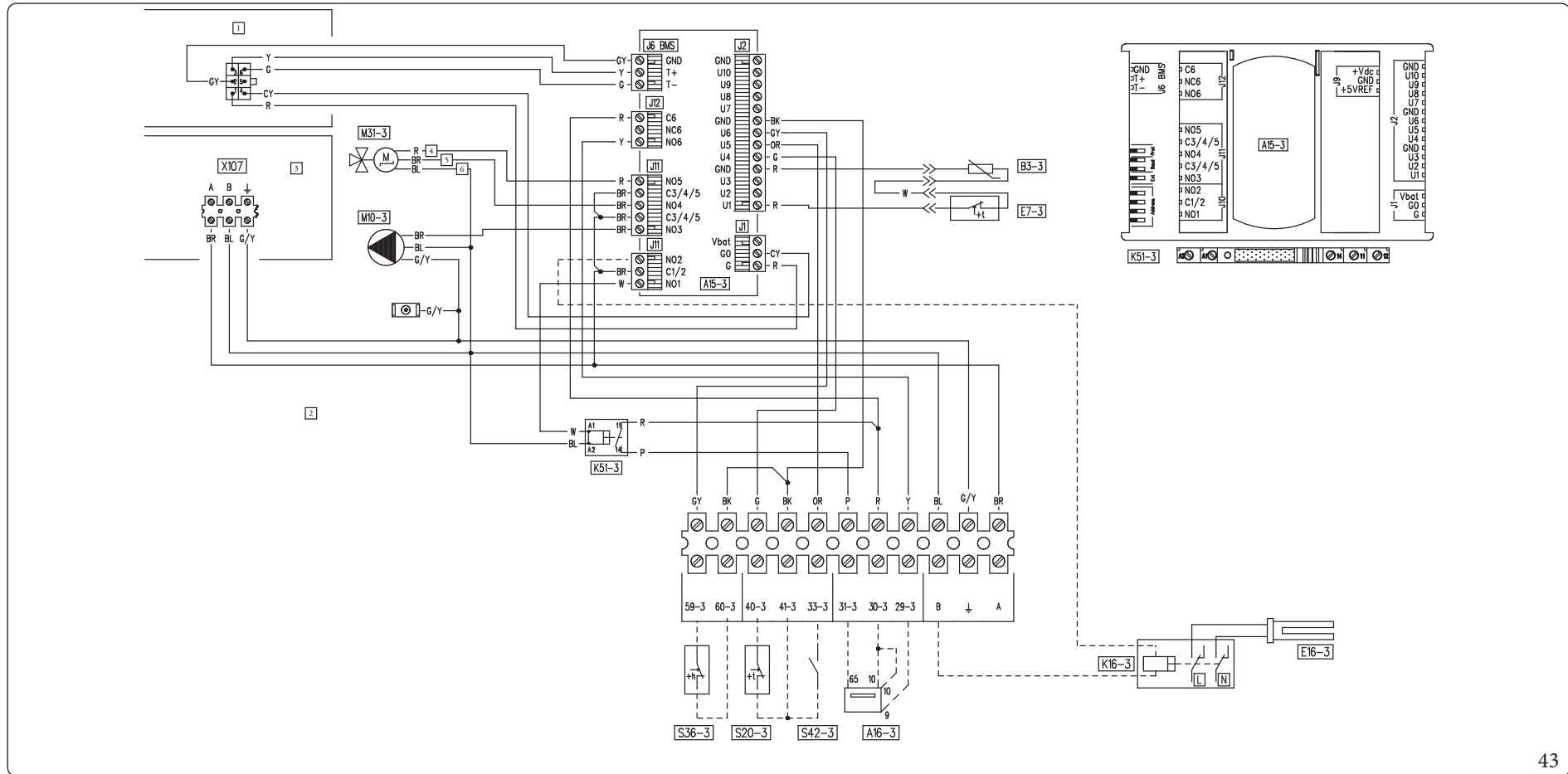

Key (Fig. 43):

- A15-3 - Expansion zone 3
- A16-3 - Zone 3 dehumidifier (optional)
- B3-3 - Zone 3 flow probe
- E7-3 - Zone 3 Safety thermostat (low temperature)
- E16-3 - Zone 3 external system integrative resistance (optional)
- K16-3 - Zone 3 system integration resistance relay (optional)
- K51-3 - Zone 3 air conditioning control relay
- M10-3 - Zone 3 circulator pump
- M31-3 - zone 3 mixing valve

- S20-3 - Zone 3 room thermostat (optional)
- S36-3 - Zone 3 humidistat (optional)
- S42-3 - Zone 3 dehumidifier alarm (optional)
- 1 - Main panel
- 2 - Optional kit panel
- 3 - Control panel
- 4 - Closed
- 5 - Open
- 6 - Common

- G - Green
- R - Red
- BL - Blue
- BR - Brown
- CY - Cyan
- BK - Black
- GY - Grey
- W - White
- OR - Orange
- P - Purple
- Y - Yellow
- G/Y - Yellow/Green

Interfaceboard - settings switch

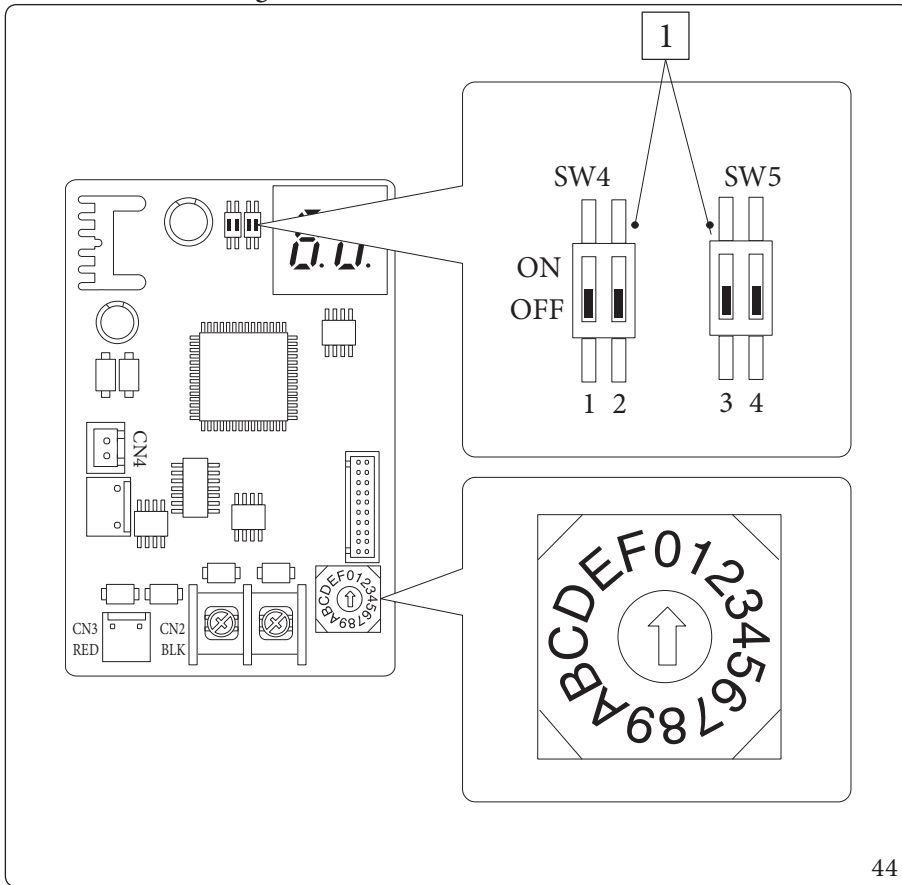

Key (Fig. 44):

1 - Factory setting: do not change

INSTALLER

USER

MAINTENANCE/TECHNICIAN

TECHNICAL DATA

Interface board - indicator LED

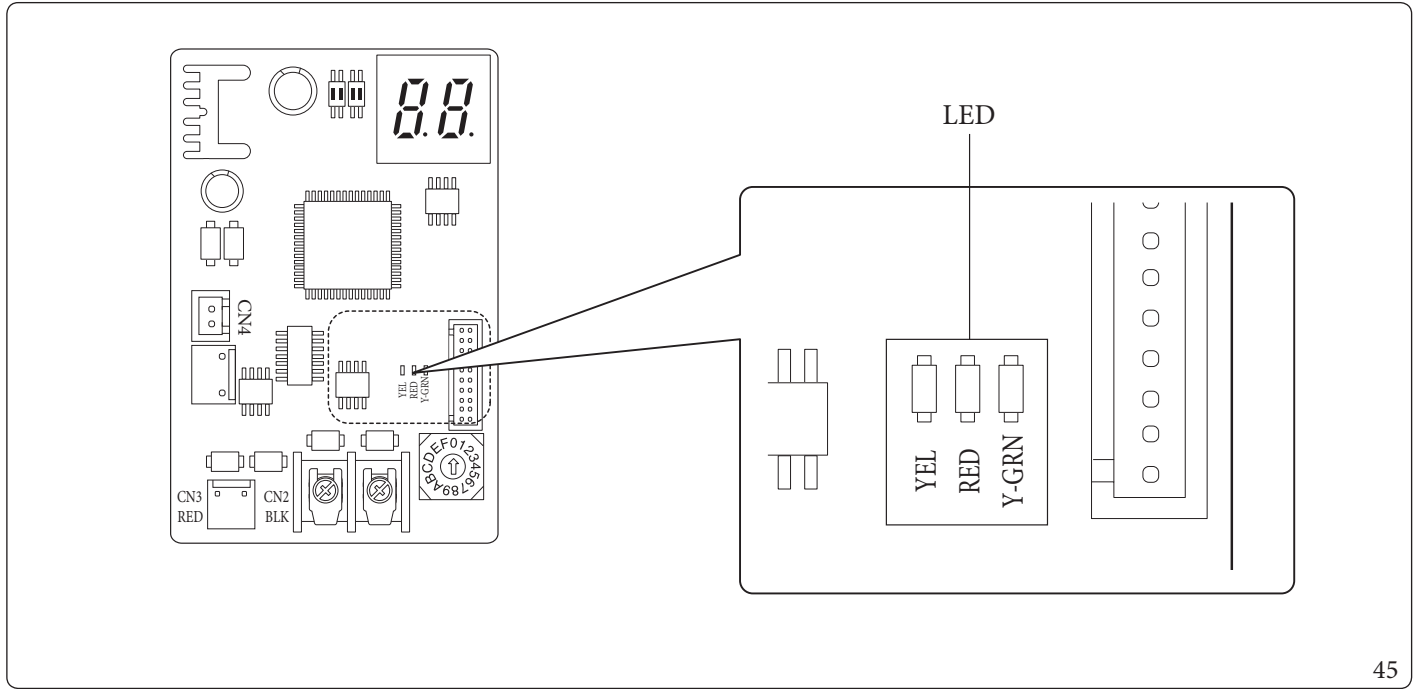

Key (Fig. 45):

Red LED flashing = Communication between interface board and P.C.B. valid

Green LED flashing = Communication between interface board and Outdoor Unit valid

Yellow LED = Not Used

Interface board - 7-segment display

During normal operation, the display shows "A0" for 1 second, followed by "30" for 1 second:

	SEGMENTS
VALID COMMUNICATION	

In case of an error of the Outdoor Unit, a sequence of two digits at a time is displayed: "E" plus Outdoor Unit error code:

ERROR CODES	SEGMENTS
E101	

3.7 SYSTEM FILTER

The appliance has a filter on the system return pipe to keep the system in good operating conditions.

Periodically and when necessary, the filter can be cleaned as described below (Fig. 46).

Close the taps (4), drain the water contents in the indoor unit using the draining valve (Det. 35, Fig. 27).

Open the cap (1) and clean the filter (2).

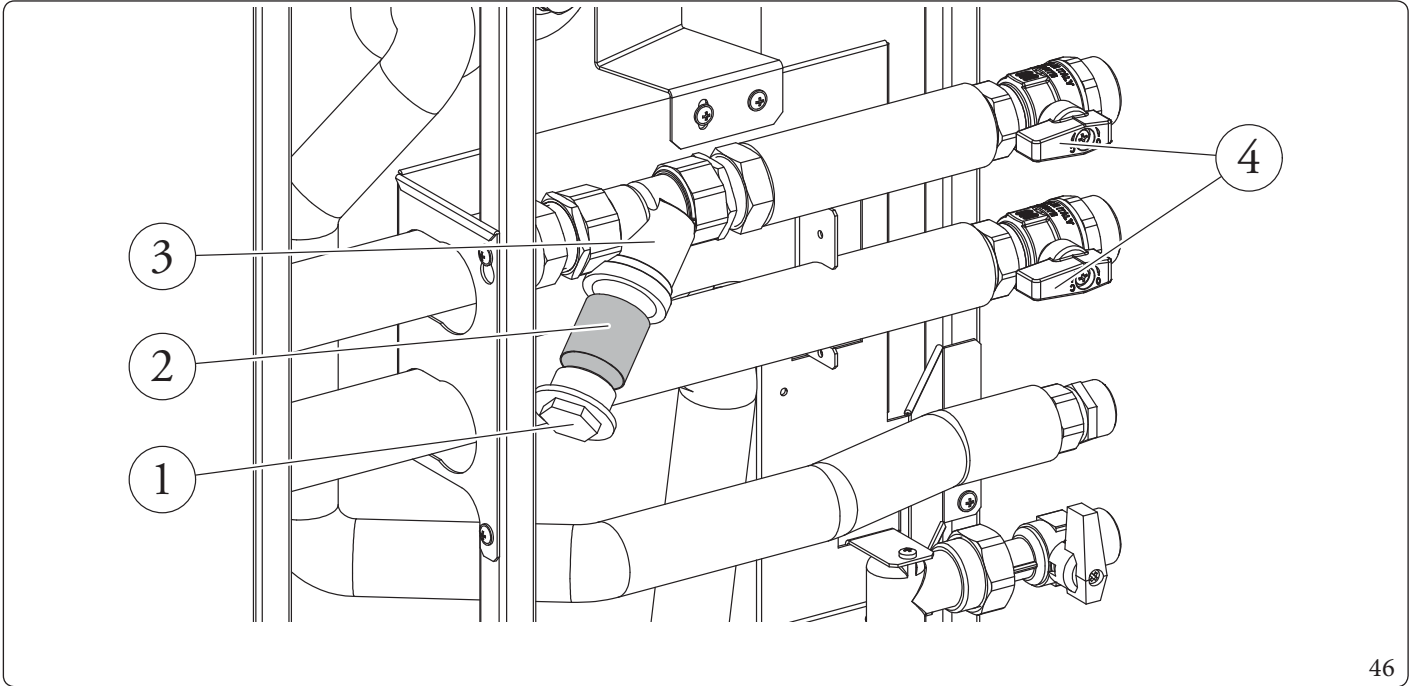

3.8 TROUBLESHOOTING



Maintenance operations must be carried out by an authorised company (e.g. Authorised After-Sales Technical Assistance Centre).

Noise due to air in the system.

Check opening of the special air vent valve cap (Part. 12, Fig. 27).

Make sure the system pressure and expansion tank factory-set pressure values are within the set limits.

The factory-set pressure values of the expansion vessel must be 1.0 bar, the value of system pressure must be between 1 and 1.2 bar.

3.9 P.C.B. PROGRAMMING

The water heater is set up for possible programming of the operation parameters. By modifying these parameters as described below, the system can be adapted according to specific needs.

To view the advanced functioning parameters of "DHW" menu you need to enter the "General information" sub-menu and select "Access level", enter the access code and confirm with "OK" (Fig. 28).

Select "**Login type = Service**", press "OK" and go back to the main screen using "RESET".

Enter the "DHW" menu and adjust the parameters below as needed.

To save the parameter change, press the "OK" button (Fig. 28).

Exit the menu with type "User" access, waiting the 4 minutes of inactivity or re-entering the "General settings" submenu and select "Access level", enter the correct code, confirm with "OK" and select "**Login type = User**", press "OK" to confirm.

DHW	
Menu item	Description
Anti-legionella	Manages the anti-legionella function.
Configuration	DHW (Domestic hot water) configuration parameters

DHW / Anti-legionella				
Menu item	Description	Range	Default	Customised value
Anti-legion.cycle time	Establishes the time of activation of the anti-legionella function.	00:00 – 23:59	02:00	
Anti-legion.cycle day	Establishes the day of activation of the anti-legionella function.	None / Monday - Sunday / All	None	
Max antilegion. time	Time after which an alarm is signalled for incomplete anti-legionella cycle.	1 - 48 (h)	3h	

DHW / Configuration				
Menu item	Description	Range	Default	Customised value
DHW hysteresis	The system activation temperature in DHW (Domestic hot water) is given by the set DHW (Domestic hot water) – DHW (Domestic hot water) hysteresis	1 ÷ 12 °C	5 °C	
DHW flow offset	The DHW (Domestic hot water) flow temperature is given by the DHW (Domestic hot water) set + DHW (Domestic hot water) flow offset	0 - 55 °C	10 °C	
Priority	In case of simultaneous heat./cool. system and DHW request, the heat pump will give priority to DHW or to the system.	DHW / CH	DHW	
Max time DHW	Time after which an alarm is signalled for incomplete DHW (Domestic hot water).	1 - 48 (h)	5h	

To view the advanced functioning parameters of "Zones" menu you need to enter the "General settings" sub-menu and select "Access level", enter the access code and confirm with "OK" (Fig. 28).

Select "**Login type = Service**", press "OK" and go back to the main screen using "RESET".

Enter the "Zones" menu and adjust the parameters described below as needed.

To save the parameter change, press the "OK" button (Fig. 28).

Exit the menu with type "Service" access, waiting the 4 minutes of inactivity or re-entering the "General settings" submenu and select "User", enter the correct code, confirm with "OK" and select "**Login type = User**", press "OK" to confirm.

Zones / Zone 1 / Configuration	
Menu item	Description
Enablings	
Thermoreg. CH	Central heating thermoregulation setting sub-menu
Thermoreg. Cool.	Cooling thermoregulation setting sub-menu

Zones / Zone 1 / Configuration / Enablings				
Menu item	Description	Range	Default	Customised value
Mode	Establishes the zone 1 operating mode	CH Cool. Cool+CH	Cool+CH	
Enable remote contr.	Enables the operation of a remote device. - No = No remote control installed - Panel = Remote zone control - Probe = Temperature and humidity probe	No Panel Probe	No	
Room. probe modul.	Enables modulation with room probe	Yes / No	Yes	
Enable room thermostat	Enable operation of a room thermostat to check the zone	Yes / No	Yes	
Enable dew point	In the presence of a remote device, calculation of the dew point. The calculation is particularly needed in case of radiant panel systems.	Yes / No	Yes	
Enable humidistat	Enables the operation of a humidistat	No / Yes	No	
Enable dehumidifiers	Enables the operation of a dehumidifier	Yes / No	No	
Max dehum. temp.	Maximum flow temperature acceptable for the dehumidifier, beyond which it is kept switched off.	10 - 50°C	25°C	
Dehum. alarm set	Maximum flow set calculated, acceptable by the dehumidifier.	10 - 50°C	25°C	
Ext. probe modul.	Thermoregulation with external probe	No / Yes	No	

INSTALLER

USER

MAINTENANCE TECHNICIAN

TECHNICAL DATA

Zones / Zone 1 / Configuration / Thermoreg. CH				
Menu item	Description	Range	Default	Customised value
Max flow set	Without the external probe it defines the maximum flow temperature that can be set by the user. With the external probe present it defines the maximum flow temperature corresponding to operation with minimum external temperature	20 ÷ 65°C	55°C	
Min flow set	Without the external probe it defines the minimum flow temperature that can be set by the user. With the external probe present it defines the minimum flow temperature corresponding to operation with maximum external temperature	20 ÷ 65°C	20°C	
Min. outside temp.	With the external probe present it defines at what minimum external temperature the system must operate at the maximum flow temperature	-25 ÷ +15°C	-5°C	
Max. outside temp.	With the external probe present it defines at what maximum external temperature the system must operate at the minimum flow temperature	-5 ÷ +45°C	25°C	

Zones / Zone 1 / Configuration / Thermoreg. Cool.				
Menu item	Description	Range	Default	Customised value
Max flow set	Without the external probe it defines the maximum flow that can be set by the user. With the external probe present it defines the maximum flow temperature corresponding to operation with minimum external temperature	5 ÷ 25°C	20°C	
Min flow set	Without the external probe it defines the minimum flow that can be set by the user. With the external probe present it defines the minimum flow temperature corresponding to operation with maximum external temperature	5 ÷ 25°C	7°C	
Min. outside temp.	With the external probe present, it defines at what maximum external temperature the system must operate at the minimum flow temperature	20 ÷ 45°C	25°C	
Max. outside temp.	With the external probe present, it defines at what minimum external temperature the system must operate at the maximum flow temperature	20 ÷ 45°C	35°C	

Zones/Zone 2(*)/Configuration

Menu item	Description
Enablings	
Thermoreg. CH	Central heating thermoregulation settings sub-menu
Thermoreg. Cool.	Cooling thermoregulation setting sub-menu

(*) if present.

Zones/Zone 2(*)/Configuration/Enablings

Menu item	Description	Range	Default	Customised value
Mode	Establishes the zone 2 operating mode	CH Cool. Cool+CH	Cool+CH	
Enable remote contr.	Enables the operation of a remote device. - No = No remote control installed - Panel = Remote zone control - Probe = Temperature and humidity probe	No Panel Probe	No	
Room. probe modul.	Enables modulation with room probe	Yes/No	Yes	
Enable room thermostat	Enable operation of a room thermostat to check the zone	Yes/No	Yes	
Enable dew point	In the presence of a remote device, calculation of the dew point. The calculation is particularly needed in case of radiant panel systems.	Yes/No	Yes	
Enable humidistat	Enables the operation of a humidistat	No/Yes	No	
Enable dehumidifiers	Enables the operation of a dehumidifier	Yes/No	No	
Max dehum. temp.	Maximum flow temperature acceptable for the dehumidifier, beyond which it is kept switched off.	10 - 50°C	25°C	
Dehum. alarm set	Maximum flow set calculated, acceptable by the dehumidifier.	10 - 50°C	25°C	
Ext. probe modul.	Thermoregulation with external probe	No/Yes	No	

(*) if present.

INSTALLER

USER

MAINTENANCE/TECHNICIAN

TECHNICAL DATA

Zones / Zone 2 (*) / Configuration / Thermoreg. CH

Menu item	Description	Range	Default	Customised value
Max flow set	Without the external probe it defines the maximum flow temperature that can be set by the user. With the external probe present it defines the maximum flow temperature corresponding to operation with minimum external temperature	20 ÷ 65°C	45°C	
Min flow set	Without the external probe it defines the minimum flow temperature that can be set by the user. With the external probe present it defines the minimum flow temperature corresponding to operation with maximum external temperature	20 ÷ 65°C	25°C	
Min. outside temp.	With the external probe present it defines at what minimum external temperature the system must operate at the maximum flow temperature	-25 ÷ +15°C	-5°C	
Max. outside temp.	With the external probe present it defines at what maximum external temperature the system must operate at the minimum flow temperature	-5 ÷ +45°C	25°C	

(*) if present.

Zones / Zone 2 (*) / Configuration / Thermoreg. Cool.

Menu item	Description	Range	Default	Customised value
Max flow set	Without the external probe it defines the maximum flow that can be set by the user. With the external probe present it defines the maximum flow temperature corresponding to operation with minimum external temperature	5 ÷ 25°C	20°C	
Min flow set	Without the external probe it defines the minimum flow that can be set by the user. With the external probe present it defines the minimum flow temperature corresponding to operation with maximum external temperature	5 ÷ 25°C	18°C	
Min. outside temp.	With the external probe present, it defines at what maximum external temperature the system must operate at the minimum flow temperature	20 ÷ 45°C	25°C	
Max. outside temp.	With the external probe present, it defines at what minimum external temperature the system must operate at the maximum flow temperature	20 ÷ 45°C	35°C	

(*) if present.

Zones / Zone 3 (*) / Configuration

Menu item	Description
Enablings	
Thermoreg. CH	Central heating thermoregulation settings sub-menu
Thermoreg. Cool.	Cooling thermoregulation setting sub-menu

(*) if present.

Zones / Zone 3 (*) / Configuration / Enablings

Menu item	Description	Range	Default	Customised value
Mode	Establishes the zone 3 operating mode	CH Cool. Cool+CH	Cool+CH	
Enable remote contr.	Enables the operation of a remote device. - No = No remote control installed - Panel = Remote zone control - Probe = Temperature and humidity probe	No Panel Probe	No	
Room. probe modul.	Enables modulation with room probe	Yes/No	Yes	
Enable room thermostat	Enable operation of a room thermostat to check the zone	Yes/No	Yes	
Enable dew point	In the presence of a remote device, calculation of the dew point. The calculation is particularly needed in case of radiant panel systems.	Yes/No	Yes	
Enable humidistat	Enables the operation of a humidistat	No/Yes	No	
Enable dehumidifiers	Enables the operation of a dehumidifier	Yes/No	No	
Max dehum. temp.	Maximum flow temperature acceptable for the dehumidifier, beyond which it is kept switched off.	10 - 50°C	25°C	
Dehum. alarm set	Maximum flow set calculated, acceptable by the dehumidifier.	10 - 50°C	25°C	
Ext. probe modul.	Thermoregulation with external probe	No/Yes	No	

(*) if present.

INSTALLER

USER

MAINTENANCE TECHNICIAN

TECHNICAL DATA

Zones / Zone 3 (*) / Configuration / Thermoreg. CH

Menu item	Description	Range	Default	Customised value
Max flow set	Without the external probe it defines the maximum flow temperature that can be set by the user. With the external probe present it defines the maximum flow temperature corresponding to operation with minimum external temperature	20 ÷ 65°C	45°C	
Min flow set	Without the external probe it defines the minimum flow temperature that can be set by the user. With the external probe present it defines the minimum flow temperature corresponding to operation with maximum external temperature	20 ÷ 65°C	25°C	
Min. outside temp.	With the external probe present it defines at what minimum external temperature the system must operate at the maximum flow temperature	-25 ÷ +15°C	-5°C	
Max. outside temp.	With the external probe present it defines at what maximum external temperature the system must operate at the minimum flow temperature	-5 ÷ +45°C	25°C	

(*) if present.

Zones / Zone 3 (*) / Configuration / Thermoreg. Cool.

Menu item	Description	Range	Default	Customised value
Max flow set	Without the external probe it defines the maximum flow that can be set by the user. With the external probe present it defines the maximum flow temperature corresponding to operation with minimum external temperature	5 ÷ 25°C	20°C	
Min flow set	Without the external probe it defines the minimum flow that can be set by the user. With the external probe present it defines the minimum flow temperature corresponding to operation with maximum external temperature	5 ÷ 25°C	18°C	
Min. outside temp.	With the external probe present, it defines at what maximum external temperature the system must operate at the minimum flow temperature	20 ÷ 45°C	25°C	
Max. outside temp.	With the external probe present, it defines at what minimum external temperature the system must operate at the maximum flow temperature	20 ÷ 45°C	35°C	

(*) if present.

To access the "Support" menu, press the "MENU" button (Fig. 28). Go to the submenu "General settings" and select "Access level". Insert the relative access code and customise the parameters described below according to your requirements.

To save the change of the parameters described below, press the "OK" button (Fig. 28).

Exit the "Support" menu waiting 4 minutes or enter the appropriate access code for the "User" menu.

You can exit the assistance menu by entering the appropriate access code under the "Access level" item and selecting the item

Login type / User

At the end, press "OK" to confirm.

After 4 minutes without setting any changes within the "Support" menu, the system automatically returns to the "User" menu.

Menu / General settings		
Menu item	Description	Range
Factory setting	Allows to reset all parameters with factory values.	Yes/No

Menu / Support	
Menu item	Description
System definition	Sub-menu to define the devices connected to the system
Heat pump	Heat pump operating parameters sub-menu
Integration	System integration setting sub-menu
Manual drives	Submenu for load operation check
Special parameters	Parameters for various uses

Menu / Support / System definition				
Menu item	Description	Range	Default	Customised value
Number of zones	Defines the number of zones present	1-3	1	
Main zone	Defines the main zone of the system in which the remote panel will be used	1-2-3	1	
External probe (*)	This defines the type of external probe enabled. - IU = indoor unit - OU = outdoor unit.	OU / IU	OU	
External probe corr.	Correction of the external probe value	-9 +9	0	
Photovoltaic function	Enables the operation combined with a photovoltaic system.	Yes / No	No	
System supervision	Enabling connection to Dominus or System supervisor	No/Domin/ BMS	No	
Activation time	Waiting time before activation of the system setpoint correction	1 - 120	20	
Increase time	Time interval for the increase or decrease of 1°C of correction of the system setpoint	1 - 20	5	
Max CH adjust	Max correction during central heating mode	0 - 10	0	
Max Cool. adjust	Max correction during cooling mode.	0 - 10	0	

Menu/Support/Heat pump	
Menu item	Description
HP Type	
Powers	
Timers	
Meters	

Menu/Service/Heat pump/HP Type				
Menu item	Description	Range	Default	Customised value
HP Type	Setting the indoor unit.	MHP / MHP Mini	MHP	

Menu/Support/Heat pump/Powers				
Menu item	Description	Range	Default	Customised value
HP Model	Setting the connected outdoor unit. Do not use the item "No".	No / 4 / 6 / 9 / 12 / 14 / 16	9	
HP power off	Enable the Disabling function of the heat pump. By selecting "Reduct.", it is possible to reduce the heat pump performance to the power set in the parameter "Power in reduced"	No / Yes / Reduct.	No	
Power in reduced	Power percentage in reduction mode.	10 ÷ 100 %	75 %	

Menu / Support / Heat pump / Timers				
Menu item	Description	Range	Default	Customised value
Anti-cycle time	Not used	0-840 s	180 s	
Ramp time	Not used	0-840 s	0 s	
Req. delay time TA	In the case of both the room thermostat and the Zone Panel, the request to the appliance occurs with a delay set with respect to the request to the zones.	0-600 s	0 s	
Prec. end wait time	Not used	0-100 s	0 s	

Menu/Support/Heat pump/Pump				
Menu item	Description	Range	Default	Customised value
Pump mode	Enable the pump operation with speed set "Max Sp." or the modulating mode with tracking of the modulating temperature ("Modul.") differential.	Max Sp. / Modul.	Max Sp.	
Min pump speed	Value of minimum speed used in modulating operation	20 – 100 %	100 %	
Max pump speed	Heat pump circulator speed	20 – 100 %	100 %	
Pump T Delta	Not used	2 – 20	5	
Automatic vent	Not used	No/Yes	No	

Menu/Support/Integration				
Menu item	Description	Range	Default	Customised value
Min. integration temp.	Temperature threshold below which integration is activated at the heat pump in central heating.	-25 ÷ +35 °C (*)	-20 °C	
DHW integration mode.	Mode of intervention of the DHW (Domestic hot water) integration and resistance	Met. / Altern.	Altern.	
CH integration mode	Mode of intervention of the central heating / C.H. integration and resistance	Met. / Altern.	Altern.	
Concomitant mode	Enabling of conjunction function 0 = No 1 = C.H./Cool. 2 = Only Cool. 3 = C.H. only	0 - 3	0	
Enable DHW integr.	Enabling of generators for the DHW Mode	0 = HP 1 = HP-Int 2 = Int	HP	
Enable heat integr.	Enabling of generators for the Central heating mode.	0 = HP 1 = HP-Int 2 = Int	HP	
CH wait time	Waiting time to reach the setting set before activation of the integration in room central heating / C.H.	20 ÷ 540'	60 min	
DHW wait time	Waiting time to reach the setting set before activation of the integration in the production of domestic hot water	20 ÷ 540'	120 min	
Time preceding DHW	Do not use	-	-	
Pre-heating time	Do not use	-	-	
Integration band	Setting of the activation band equal to the activation delay time will activate the additional heater.	1 - 20 °C	5 °C	
Reset HP meter	Reset the number of operating hours of the heat pump	Yes/No	No	
Reset plant int. met.	Reset hours of operation of the central heating / C.H. integration	Yes/No	No	
Reset sanitary int. met.	Reset hours of operation of the DHW (Domestic hot water) integration	Yes/No	No	

(*) For outdoor temperatures below -20°C, the capacity of the heat pump is not guaranteed.

INSTALLER

USER

MAINTENANCE TECHNICIAN

TECHNICAL DATA

Menu/Support/Manual drives(*)				
Menu item	Description	Range	Default	Customised value
Sys./DHW 3-way	Manual activation of the DHW (Domestic hot water) 3-way	Yes/No	No	
Enable sys.resistance	Manual activation of the system resistance	Yes/No	No	
Enable DHW resistance 1	Manual activation of the DHW (Domestic hot water) resistance 1	Yes/No	No	
Zone 1 circulator	Manual activation of zone 1 pump	Yes/No	No	
Dehumidifier zone 1	Manual activation of the dehumidifier in neutral air on zone 1	Yes/No	No	
Zone 1 air conditioning	Manual activation of the dehumidifier in cooled air on zone 1	Yes/No	No	
Zone 2 circulator	Manual activation of zone 2 pump	Yes/No	No	
Dehumidifier zone 2	Manual activation of the dehumidifier in neutral air on zone 2	Yes/No	No	
HP Flowmeter	Shows the flow rate read on the flowmeter	0-4000l/h		
Circulator speed		0-100%	0%	
Mixer zone 2	Manual activation of the mixing valve on zone 2	Stop Close Open	Stop	
Zone 2 air conditioning	Manual activation of the dehumidifier in cooled air on zone 2	Yes/No	No	
Zone 3 mixing valve	Manual activation of the mixing valve on zone 3	Stop Close Open	Stop	
Zone 3 circulator	Manual activation of zone 3 pump	Yes/No	No	
Dehumidifier zone 3	Manual activation of the dehumidifier in neutral air on zone 3.	Yes/No	No	
Zone 3 air conditioning	Manual activation of the air conditioner in cooled air in zone 3	Yes/No	No	
Hot/Cold three-way	Manual activation of the summer/winter three-way valve (M52)	Yes/No	No	

(*) If you are within the "Manual drives" menu, the 4-minute time-out for exiting the "Support" menu is not taken into account.

Menu/Service/Special parameters

Menu item	Description	Range	Default	Customised value
Dehumid. in cool.air	Dehumidification control in cooled air	Zone 1 / Zone 2	Zone 2	
Safety therm. Zone 2	Zone 2 safety thermostat	20÷80	45	
Safety therm. Zone 3	Zone 3 safety thermostat	20÷80	45	
Enable recirculation	DHW recirculation enabling	On / Off	Off	
Integr. multiplier	Not used	1÷100	10	
Enab.heat.resistance 2 (*)	Enable external central heating integrated electrical resistance	Yes / No	No	
Parameter 1	Enable flow probe Zone 1 (0 = disabled, 1 = enabled)	-1000÷1000	0	
Parameter 2	System-side electrical integration power (value multiplied by a factor of 10, e.g. 30 corresponds to a 3kW resistance)	-1000÷1000	30	
Parameter 3	Room antifreeze protection setpoint (value multiplied by a factor of 10, 40 is equal to 4°C)	-1000÷1000	50	
Parameter 4	Boost dehumidification (0 = disabled, 1 = enabled)	-1000÷1000	0	
Parameter 5	Temperature threshold below which the DHW integration to the heat pump is activated (value multiplied by a factor of 10, e.g. -200 corresponds to -20°C)	-1000÷1000	-200	
Parameter 6	Do not use	-1000÷1000	0	
Parameter 7	Do not use	-1000÷1000	0	
Parameter 8	Do not use	-1000÷1000	0	
Parameter 9	Do not use	-1000÷1000	0	
Parameter 10	Do not use	-1000÷1000	0	

(*) It is not possible to activate the recirculation function when using the external probe IU (optional).

INSTALLER

USER

MAINTENANCE/TECHNICIAN

TECHNICAL DATA

3.10 FIRST IGNITION PARAMETER SETTING

During the first activation of the appliance, it is necessary to customise the following parameters, which concern the generator operation, the type of Outdoor Unit and the type of system connected to the appliance.

In the menu

Support / Heat pump / Powers

it is necessary to set "HP Model", which corresponds to the power of the outdoor unit.

In the menu

Support / Heat pump / Timers

You can customise the device's restart delay by modifying the parameter "Anti-cycle time" and, in the presence of delayed opening systems, you can modify the parameter "Req.delay time TA".

In the menu

Support / Heat pump / Pump

it is possible to modify the heat pump circulator speed by modifying the parameter "Max pump speed".

It is necessary to adjust the pump speed according to the appliance power, to improve the operating efficiency of the machine.

It is suggested to set the following values:

- Magis Hercules Pro 4: Speed = 40%
- Magis Hercules Pro 6: Speed = 50%
- Magis Hercules Pro 9: Speed = 70%

It is also necessary to adjust the speed of the zone pumps according to the type of system present.

This operation must be carried out directly on the relative zone pump (see Par. 1.19).

The heat pump is equipped with a standard DHW (Domestic hot water) electrical resistance to which it is possible to add two additional DHW (Domestic hot water) electrical resistances (optional). The enabling of all electrical resistances is implemented through a single parameter.

The standard supplied electrical resistance is disabled as a precaution (it is necessary for the resistance to be activated only in the presence of Domestic hot water / D.H.W. in the storage tank).

If necessary, enable the electrical resistance by modifying the following parameters:

Integration / Enable DHW integr.

it is decided whether to activate only the heat pump or only the resistance or both to perform the DHW Mode.

Integration / DHW integration mode.

it is decided whether to activate the heat pump and the resistance in an alternate or simultaneous manner.

Integration / DHW wait time

decide the time that needs to lapse before activating the electrical resistance.

When the outdoor temperature is lower than:

Integration / Min. integration temp.

the DHW electrical resistance activates automatically.

The first served operating mode, in case of contemporaneity, is decided with the parameter:

Configuration / Priority

The DHW Mode can have a maximum duration, settable with the parameter

Configuration / Max time DHW

beyond which the alarm is signalled.

The heat pump can manage up to 3 distribution pumps.

To activate the correct number of distribution pumps, modify the parameter:

System definition / Number of zones

It is possible to customise the operation of each individual zone.

Each zone can be enabled for a single operating mode, modifying the parameter

Configuration / Enablings / Mode

The system request for each zone can be made from a room thermostat, which must be enabled in the menu

Configuration / Enablings / Enable room thermostat

In case a remote device is used to control the requests, it is necessary to modify the parameter

Configuration / Enablings / Enable remote contr.

If a dehumidifier is present, it is necessary to modify the parameter

Configuration / Enablings / Enable dehumidifiers

It may happen that the dehumidifier has problems with receiving a very high supply temperature. For this reason, dehumidifier ignition can be prevented until the flow water drops below the desired level.

Configuration / Enablings / Max dehum. temp.

Furthermore, if the setpoint calculated for the dehumidification is too high to carry out a request, the alarm is signalled and the dehumidifier is stopped. This value can be edited through the parameter:

Configuration / Enablings / Dehum. alarm set

In case a humidistat is used to control the dehumidification requests, it is necessary to modify the parameter

Configuration / Enablings / Enable humidistat

In the presence of a floor system, it is necessary to avoid the formation of condensate in the floor by enabling the use of the dew temperature calculation, provided a zone remote panel or a temperature/humidity probe has been installed:

Configuration / Enablings / Enable dew point

It is possible to enable the flow temperature control via the thermoregulation with external probe, by modifying the parameter

Configuration / Enablings / Ext. probe modul.

To improve system efficiency in certain types of systems, it is possible to enable the flow temperature control by modulating with room probe, by modifying the parameter

Configuration / Enablings / Room. probe modul.

The system flow temperature drops (it rises in case of cooling) when the room temperature approaches the room setpoint. Modulation with room probe can only be enabled in the presence of a zone remote device.

INSTALLER

USER

MAINTENANCE TECHNICIAN

TECHNICAL DATA

3.11 DHW (DOMESTIC HOT WATER) BOOST

In order to activate the DHW (Domestic hot water) BOOST function, it is necessary to enable the DHW (Domestic hot water) electrical resistance by changing the parameter:

Integration / Enable DHW integr.

3.12 ANTI-LEGIONELLA

The indoor unit is equipped with a function to perform a thermal shock on the storage tank.

This function brings the appliance temperature to the maximum allowed with DHW integrative resistance enabled.

The function is enabled via the menu

DHW / Anti-legionella

The function is activated at the time set via the menu

Anti-legionella / Anti-legion.cycle time

on the week day set on the menu

Anti-legionella / Anti-legion.cycle day

it is possible to activate the all day function through the "Anti-legionella" menu.

The maximum allowed duration of the function corresponds to the value set in the parameter:

Anti-legionella / Max antilegion. time

if the function is not completed within the maximum allowed time, an alarm will be triggered.



It is possible to activate the function only with DHW el. resistance and eventually a thermostatic valve must be installed at the DHW outlet to prevent burns.

3.13 DHW (DOMESTIC HOT WATER) RECIRCULATION

The DHW recirculation function provides the greatest possible comfort in domestic hot water supply by constantly circulating the water. In order to activate the DHW recirculation function, it is necessary to install the recirculation probe available in the optional kit and enable it by editing the relevant parameter:

Special parameters / Enable recirculation

Once installed, the probe makes it possible to improve the efficiency of the system by switching off the circulator in the event that the DHW temperature reaches the set DHW temperature.

The operation of the circulator can be further reduced by setting the time slots as desired in the menu:

Menu / Clock and programs / Recirculation Program

3.14 PUMP ANTI-BLOCK

The indoor unit has a function that starts the pump at least once every 24 hours for the duration of 30 seconds in order to reduce the risk of the pump becoming blocked due to prolonged inactivity.

3.15 THREE-WAY ANTI-BLOCK

The indoor unit has a function that activates the motorised three-way unit 24 hours after the last time it operated by running a complete cycle in order to reduce the risk of the three-way blocking due to prolonged inactivity.

3.16 SYSTEM SETPOINT CORRECTION

In the presence of hydraulic disconnections on the system downstream of the appliance distribution circuit, it is possible to activate a function that makes it possible to correct the request setpoint to the generator to approach the set zone setpoint as much as possible.

The corrections can be made either in central heating / C.H. or in cooling mode.

To activate this FUNCTION also in direct zone 1 it is necessary to install the flow probe for zone 1 B3-1 (optional) connected to the terminal block of the control panel as shown in figure 8 and enable it with "Parameter 1 = 1" in "Parameter 1" in Menu / Support / Special parameters".

Activation takes place by setting the parameters

System definition / Max CH adjust

System definition / Max Cool. adjust

with a value $> 0^{\circ}\text{C}$.

Following a demand, the correction begins after a time equal to

System definition / Activation time

and continue with a 1°C every time interval of

System definition / Increase time

minutes.

3.17 PHOTOVOLTAIC

If the photovoltaic contact (contact "S 39" Fig. 7) is closed, the accumulated DHW is heated to the highest settable temperature (without electrical resistance) through heat pump operation.

In case of simultaneous DHW (Domestic hot water) and system request, the system will decide which service to satisfy, in order to ensure the best comfort.

3.18 INTEGRATION WITH SYSTEM INTERNAL ELECTRICAL RESISTANCE

The heat pump can be added with system electrical resistances (optional) to be installed inside the appliance, to have an alternative source of energy available for use in central heating mode.

The enabling of all electrical resistances is implemented through a single parameter.

Enabling the internal electrical resistances is an alternative to enabling the external ones, therefore it is not possible to simultaneously manage both on a single product.

Modifying the parameter

Integration / Enable heat.integr.

it is decided whether to activate only the heat pump or only the resistance or both to perform the Central heating mode.

Modifying the parameter

Integration / CH integration mode

it is decided whether to activate the heat pump and the resistance in an alternate or simultaneous manner.

Modifying the parameter

Integration / CH wait time

decide the time that needs to lapse before activating the electrical resistance.

When the outdoor temp is below

Integration / Min. integration temp.

the electrical resistance activates automatically.

The first served operating mode, in case of contemporaneity, is decided with the parameter:

Configuration / Priority

in the "DHW" menu:

3.19 INTEGRATION WITH SYSTEM EXTERNAL ELECTRICAL RESISTANCES

System electrical resistances can be (optionally) installed outside the appliance for each zone.
For electrical connections, please see the relevant references in the wiring diagrams.
To enable the operation of resistances, it is necessary to edit the parameter by which

Integration/ Enable heat.integr.

it is decided whether to activate only the heat pump, or only the resistance, or both, to perform the Central heating mode.
Enabling the external electrical resistances is an alternative to enabling the internal ones, therefore it is not possible to simultaneously manage both on a single product. Enabling the external resistances mandatorily requires the installation of the flow probe for zone 1 called B3-1 (optional) connected to the terminal block of the control panel as shown in figure 8.
To enable the external integration resistance it is necessary to set:

Special parameters/ Enab.heat.resistance 2 = 1

Modifying the parameter

Integration/ CH integration mode

it is decided whether to activate the heat pump and the resistance in an alternate or simultaneous manner.
Modifying the parameter

Integration/ CH wait time

decide the time that needs to lapse before activating the electrical resistance.
When the outside temperature is lower than:

Integration/ Min. integration temp.

the electrical resistance activates automatically.
The first served operating mode, in case of contemporaneity, is decided with the parameter:

Configuration/ Priority,

in the "DHW" menu:



Electrical resistances inside and outside the appliance cannot be connected at the same time.

3.20 ZONE 2/3 SAFETY THERMOSTAT

In case of zone 2 or zone 3 installation, a control on the zone flow temperature is enabled which prevents the distribution of water above a certain temperature.

It is possible to modify these limits through the parameters

Special parameters/ Safety therm. Zone 2

Special parameters/ Safety therm. Zone 3

3.21 CONJUNCTION MODE

In case of simultaneous DHW (Domestic hot water) and system request, the system decides which to service to perform on the basis of an alternating logic determined by the system.

It is possible to modify this logic, so that the system simultaneously deals with both services, using the generators available.

Operation in this mode can be activated by editing the following parameters:

System definition / Concomitant mode

Moreover, also the DHW electrical resistance needs to be enabled:

Integration / Enable DHW integr.

3.22 HEAT PUMP DISABLING FUNCTION

If this function is enabled, no request from the heat pump will be fulfilled, except for the safety functions.

To enable this function, please edit the following parameters:

HP / Powers / HP power off = Yes

User / Disable HP = Yes

One can then choose whether to activate the disabling according to a schedule by setting time slots in the menu:

User / Start hourly HP disab.

User / End hourly HP disab.

or with an external contact (contact "S43" Fig. 7).

3.23 POWER REDUCTION FUNCTION

To enable this function, please edit the following parameters:

User / Disable HP = Yes

HP / Powers / HP power off = Reduct.

and set the reduced power level with the parameter

HP / Power / Power in reduced

One can then choose whether to activate the reduction according to a schedule by setting time slots in the menu:

User / Start hourly HP disab.

User / End hourly HP disab.

or with an external contact (contact "S43" Fig. 7).

3.24 DIVERTER VALVE MANAGEMENT (SUMMER / WINTER)

The unit electronics has a 230V outlet to manage the summer / winter diverter valves.

The voltage output is active when the appliance is in SUMMER mode with Cooling.

3.25 EXTERNAL PROBE SETTING

To activate the optional external probe, it is necessary to modify the parameter:

System definition / External probe

If the temperature probe is particular far from the indoor unit, it is possible to correct its value by modifying

System definition / External probe corr.

3.26 MANUAL DRIVES

In the menu

Support / Manual drives

it is possible to manage all the main appliance loads in manual mode.

These parameters must be used in case of system troubleshooting.

To correctly activate the functions, it is necessary to set the system in “stand-by”.

3.27 OUTDOOR UNIT TEST MODE FUNCTION

When using the Outdoor Unit's test mode (see outdoor condensing unit instruction manual), the Indoor Unit must be set to an operating mode other than 'Stand-by'.

The alarm 183 is triggered during the test, meaning “Test mode” in progress.

3.28 OUTDOOR UNIT PUMP DOWN

If the pump down function is used (see outdoor condensing unit instruction booklet) the indoor unit must be set in “Stand-by”.

The function can only be activated if the appliance is not under alarm.

3.29 SUPERVISION DEVICE CONFIGURATION

The appliance can be configured so that it can be controlled by the external supervision devices such as Dominus or other types of home automation systems (not supplied by Immergas).

For the configuration, it is necessary to modify the parameter

System definition / System supervision



It is not possible to configure both devices simultaneously.

3.30 DEHUMIDIFICATION BOOST FUNCTION

If there is a Immergas temperature probe, zone remote panel or modbus temperature - humidity probe and a dehumidifier, it is possible to configure the device to increase the cooling capacity of the zone by activating the dehumidifier in cooled air mode if the ambient temperature read by the probe exceeds the set value by 2°C.

3.31 DEHUMIDIFICATION FUNCTION

The dehumidification function with Immergas dehumidifiers can be carried out based on two different modes (neutral air or cooled air) and based on three different types of devices:

- 1) Zone remote panel or zone remote control;
- 2) Humidity sensor.
- 3) Humidistat.

Neutral air mode.

The first and second case, only the dehumidification request is activated if the humidity value read by the panel/humidity probe exceeds the value set in the "Set" menu.

In the third case, as soon as the humidistat On/Off contact is closed.

The dehumidification request in neutral air means starting up the Immergas dehumidifier so as to reduce the humidity without modifying the room temperature.

Cooled air mode.

In the first case, Cooled Air mode starts up if, both humidity and temperature read by the panel/remote control are greater than the set values.

In the second case, the Cooled Air mode starts up if, in addition to the humidity read by the probe is greater than the set value, the On/Off contact of the thermostat also closes.

In the third case it is activated when both On/Off contacts of the zone humidistat and thermostat are closed. The cooled air dehumidification request means activating the Immergas dehumidifier in a different mode that adds an additional room cooling capacity, in addition to dehumidification.

Cooled Air Dehumidification mode can only be activated in alternative mode or on zone 1 or on zone 2.

3.32 CASINGREMOVAL

To facilitate indoor unit maintenance the casing can be completely removed as follows:

Aesthetic profile (1) (Fig. 47).

- Remove the plastic protection caps (2) and loosen the screws (3) to remove the aesthetic profile (1).

Cover disassembly (4) (Fig. 48).

- Open the cover door (4) to make it tilt.
- Remove the rubber protection caps (5), loosen the two upper front screws and the lower screws (6) to remove the cover (4)

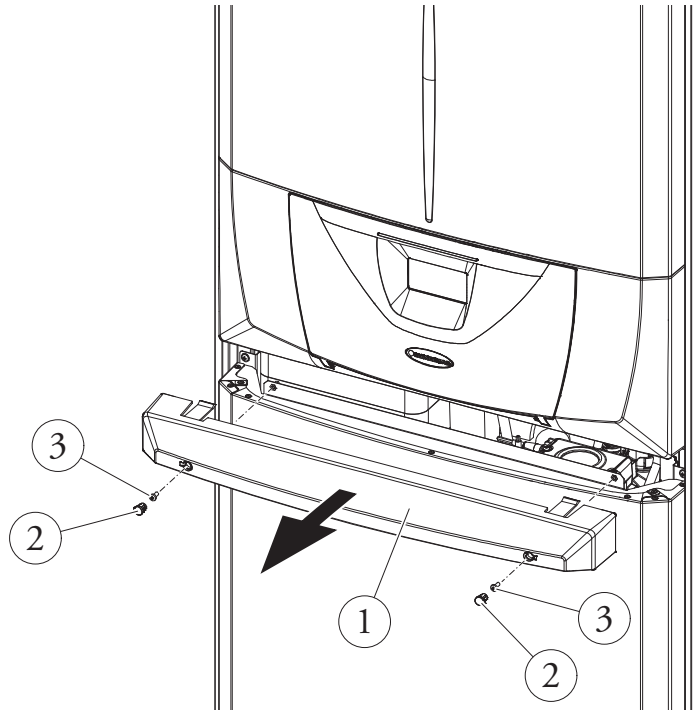

47

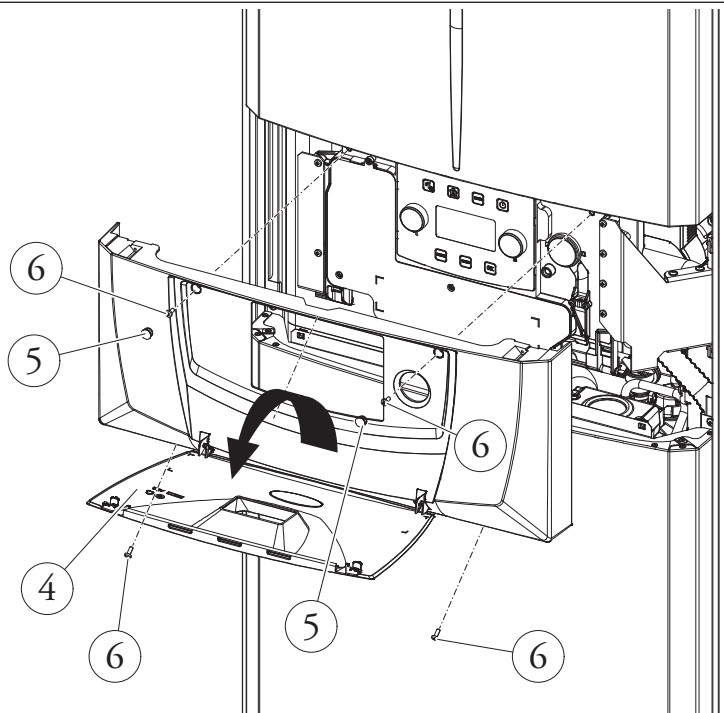

48

INSTALLER

USER

MAINTENANCE/TECHNICIAN

TECHNICAL DATA

Disassembly of the upper front (7), lower front (9) (Fig. 49)

- Disassemble the upper front (7) by loosening the two screws (8) and pushing it upwards in order to free it from the fixing slots and pulling it towards yourself (Det. A).
- Disassemble the lower front (9) by loosening the 2 screws (10a) and pushing it upwards in order to free it from the fixing slots, pulling it towards yourself (Det. B).
- Unscrew the 2 (10b) fixing screws on the control panel.
- After which, pull the control panel (11) towards yourself and turn it as shown in the figure 50.

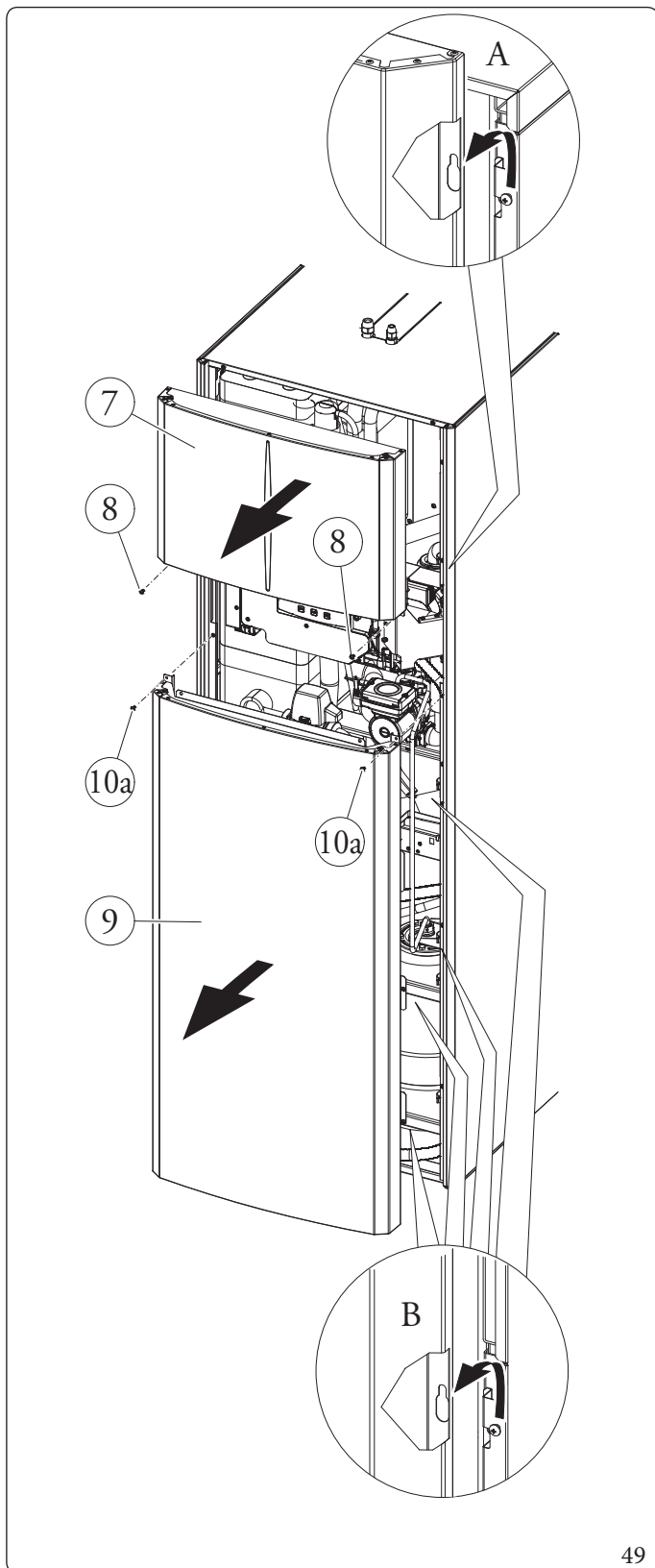

49

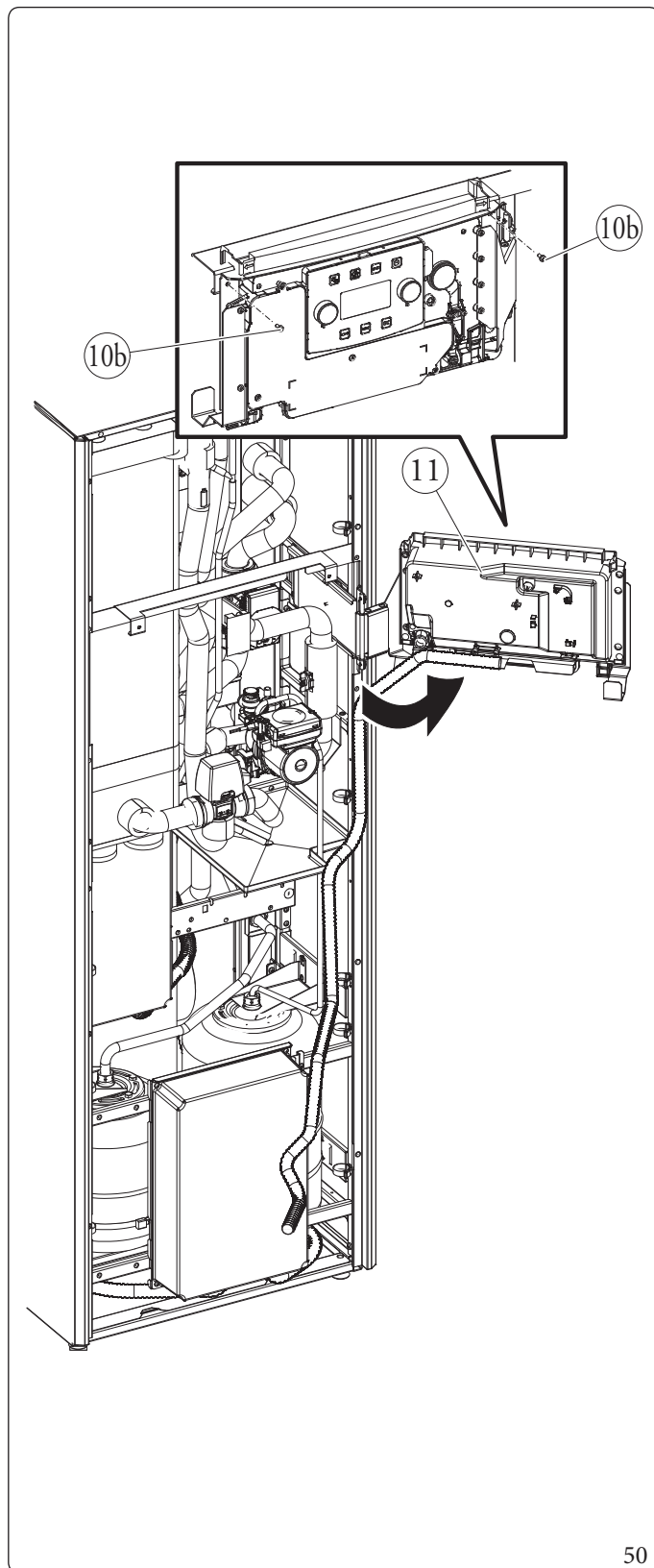

50

Right side door disassembly (15) (Fig. 51)

- Open the door (15) making it turn by at least 90° outwards.
- Remove the screw (12) in the top corner of the door (15).
- Release the door (15) from the bracket (13) just released from the screw (12) tilting it outwards and removing it from the lower pin (14).

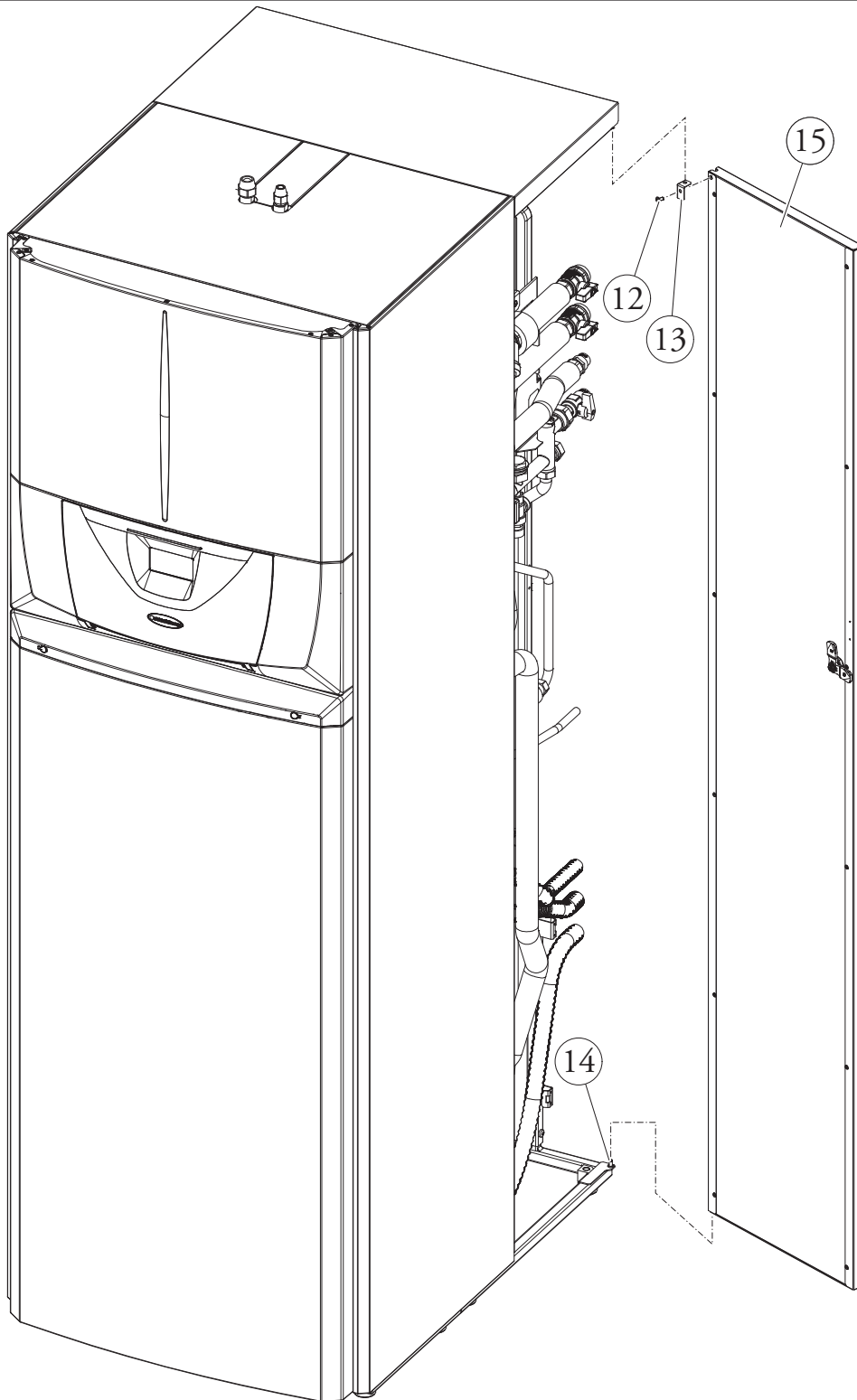

51

INSTALLER

USER

MAINTENANCE/TECHNICIAN

TECHNICAL DATA

Upper covers disassembly (16 and 18) (Fig. 52)

- Undo the fixing screws (19), pull the front cover towards you (16) to release it from the screws with the stop placed at the rear (Det. C) (see detail).
- Undo the fixing screws (17), pull the cover towards you (18) to release it from the screws with the stop placed at the rear (Det. D) (see detail).

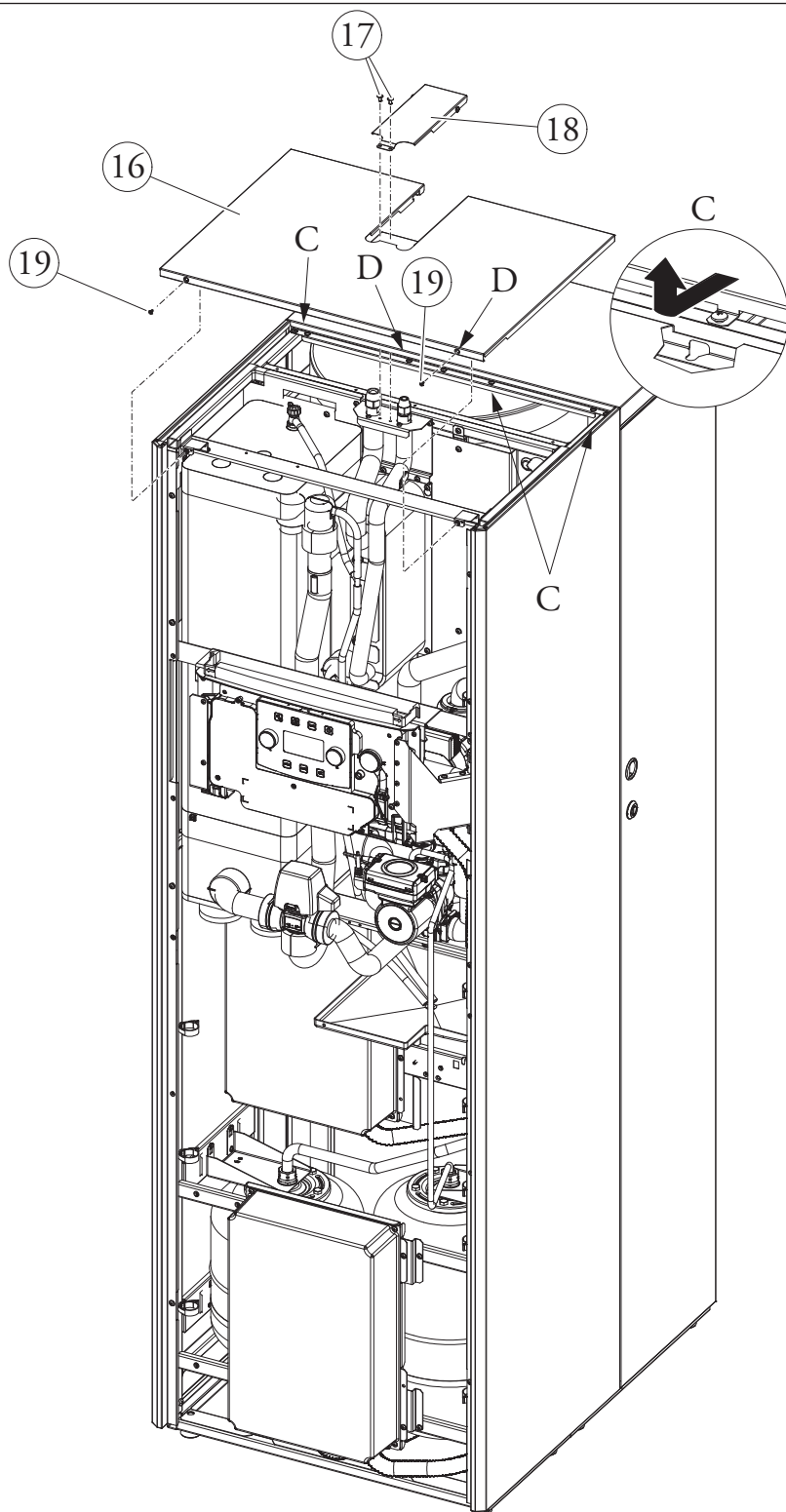

Rear cover disassembly (20) (Fig. 53)

- Undo the fixing screws (23), pull the rear cover towards you (20) to release it from the screws with the stop placed at the rear (Det. D).

Right side disassembly (21) (Fig. 53)

- Remove the right side (21) loosening the screws (22) present, then lightly push upwards in order to release the side from its seat and pull it outwards (Det. E).

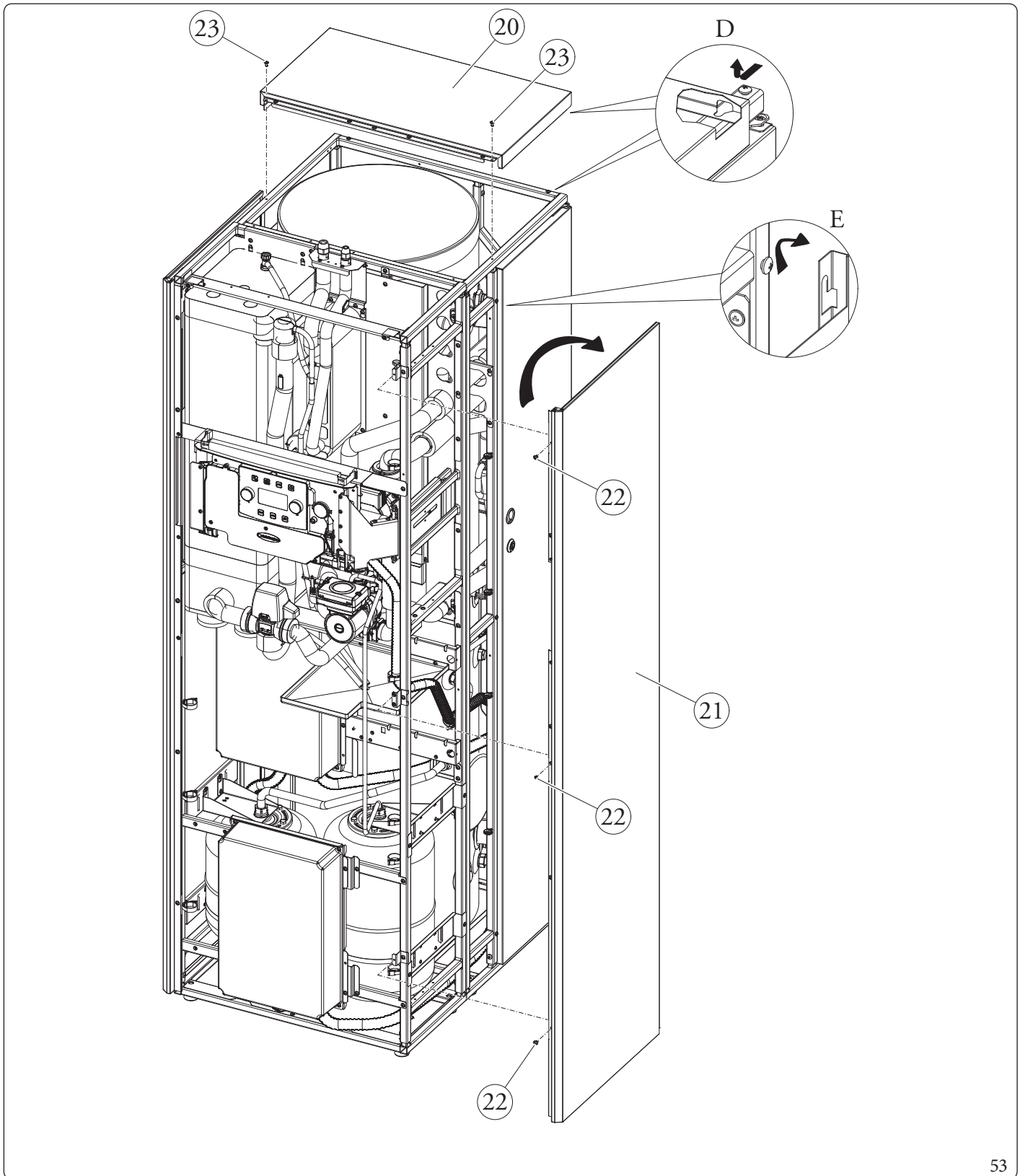

INSTALLER

USER

MAINTENANCE/TECHNICIAN

TECHNICAL DATA

Front left side disassembly (25) (Fig. 54)

- Remove the front left side panel (25) by undoing the screws (24) and then slightly push the side panel upwards in order to release the side panel from its seat and pull it outwards (Det. F).

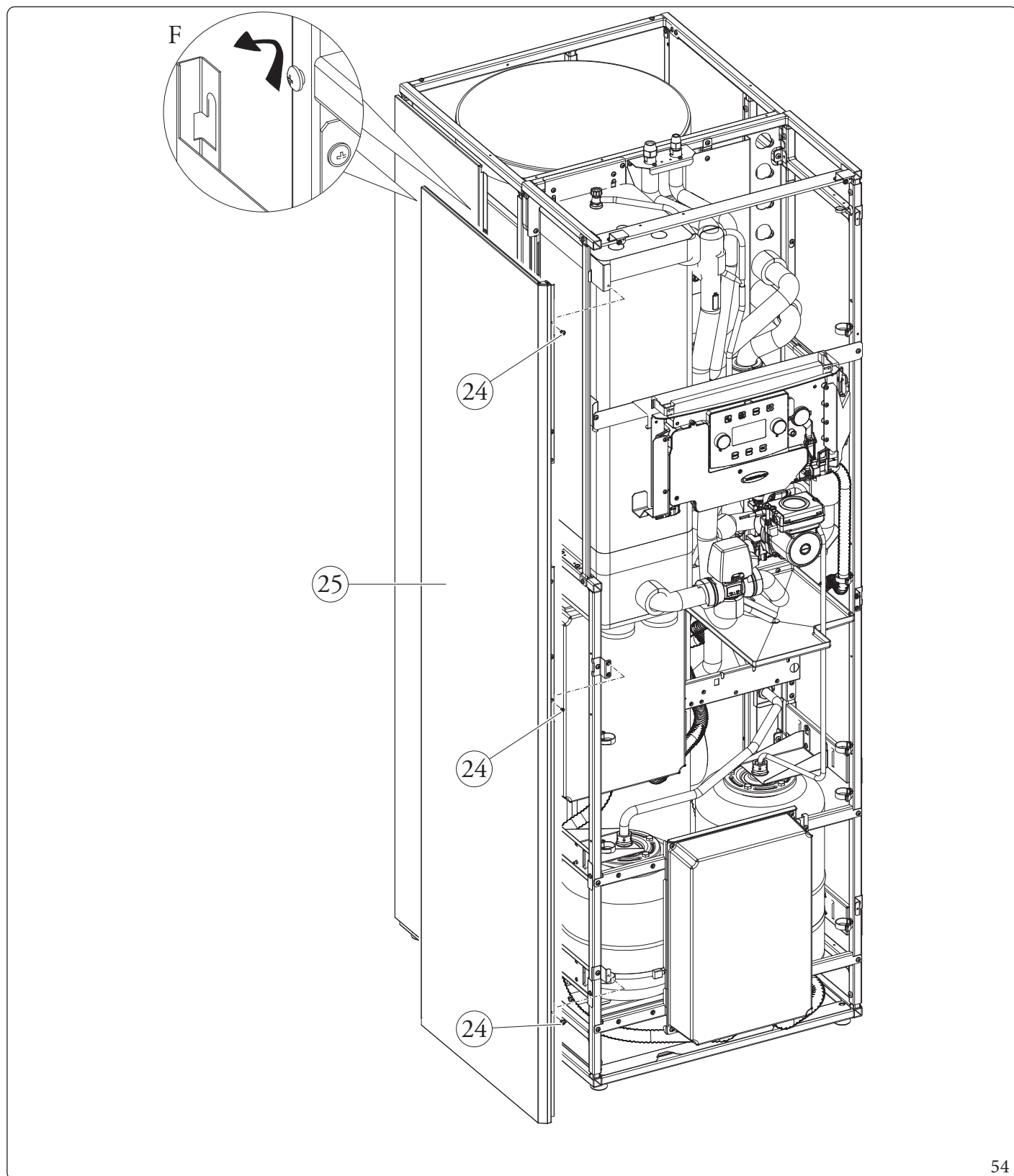

Rear left side disassembly (27) (Fig. 55)

- Remove the rear left side panel (27) by undoing the screws (26) and then slightly push the side panel upwards in order to release the side panel from its seat and pull it outwards (Det. G).

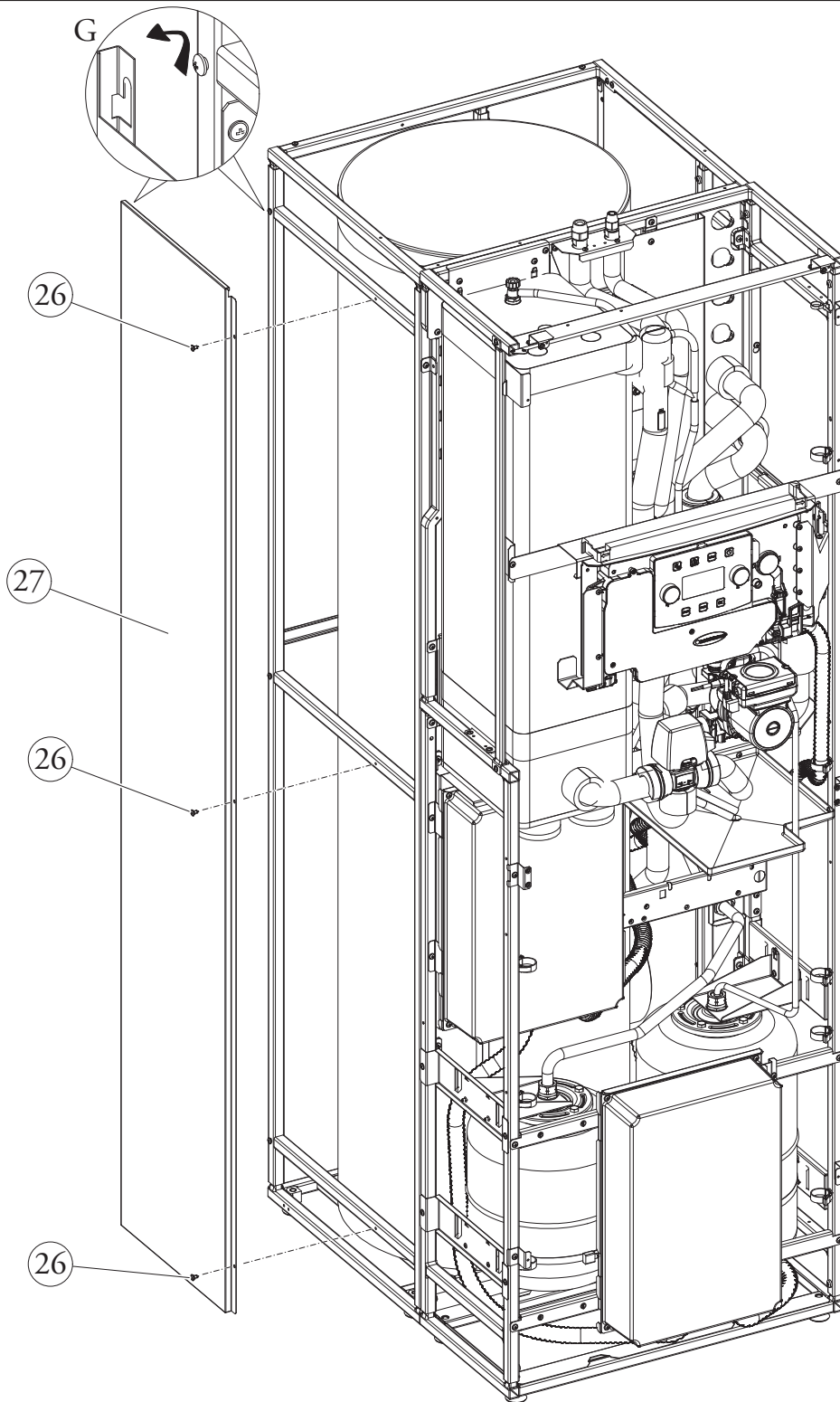

55

INSTALLER

USER

MAINTENANCE/TECHNICIAN

TECHNICAL DATA

3.33 INDOOR UNIT SEPARATION

To ease transport the indoor unit can be separated into two detached modules. To do this one must follow the instructions below and completely disassemble the casing as described in Par. 3.32.

- Remove the insulation from the fittings (1) (Fig. 56).

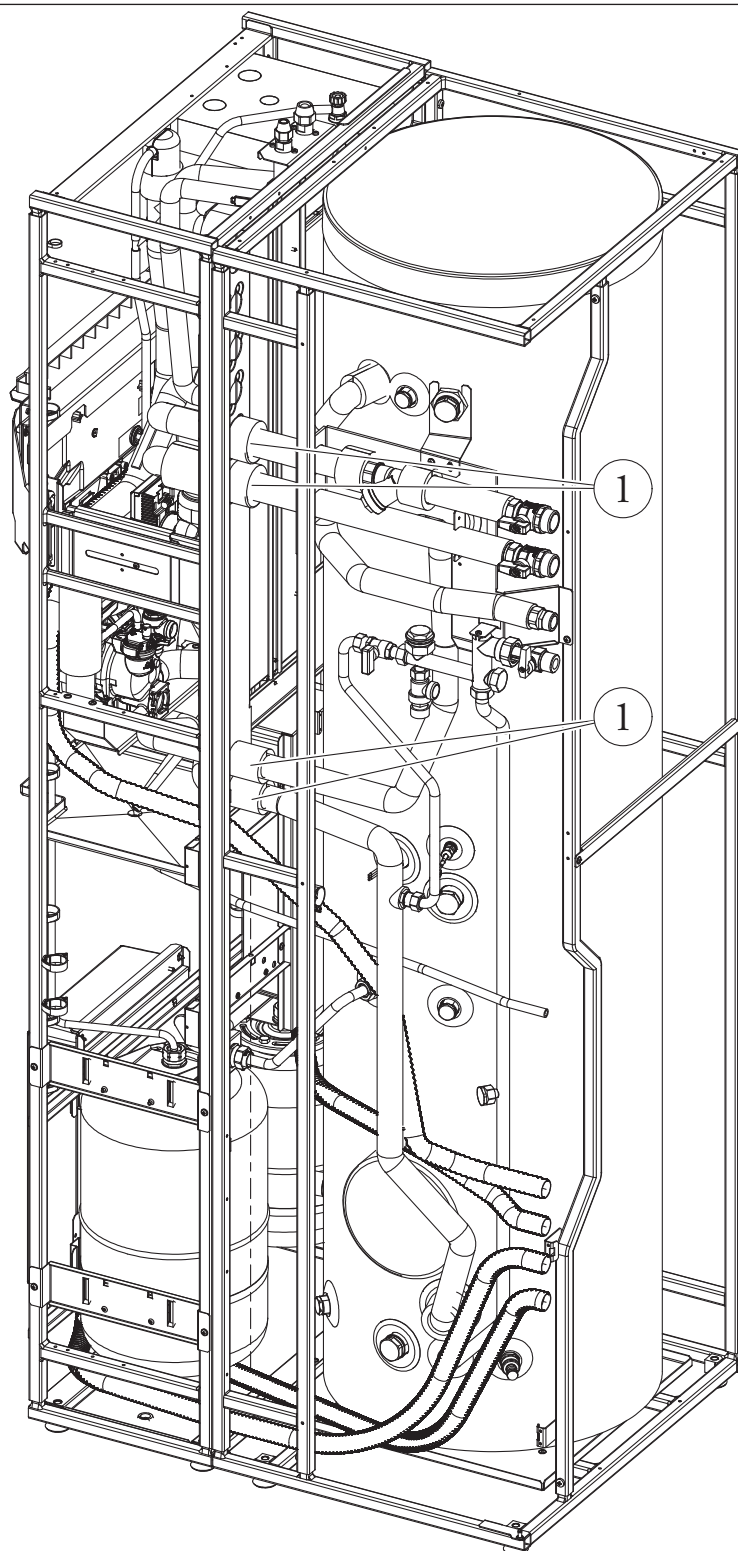

- Unscrew the fittings (2) being careful to keep the gaskets present aside.
- Disconnect the connectors (3 and 4) (Fig. 57).

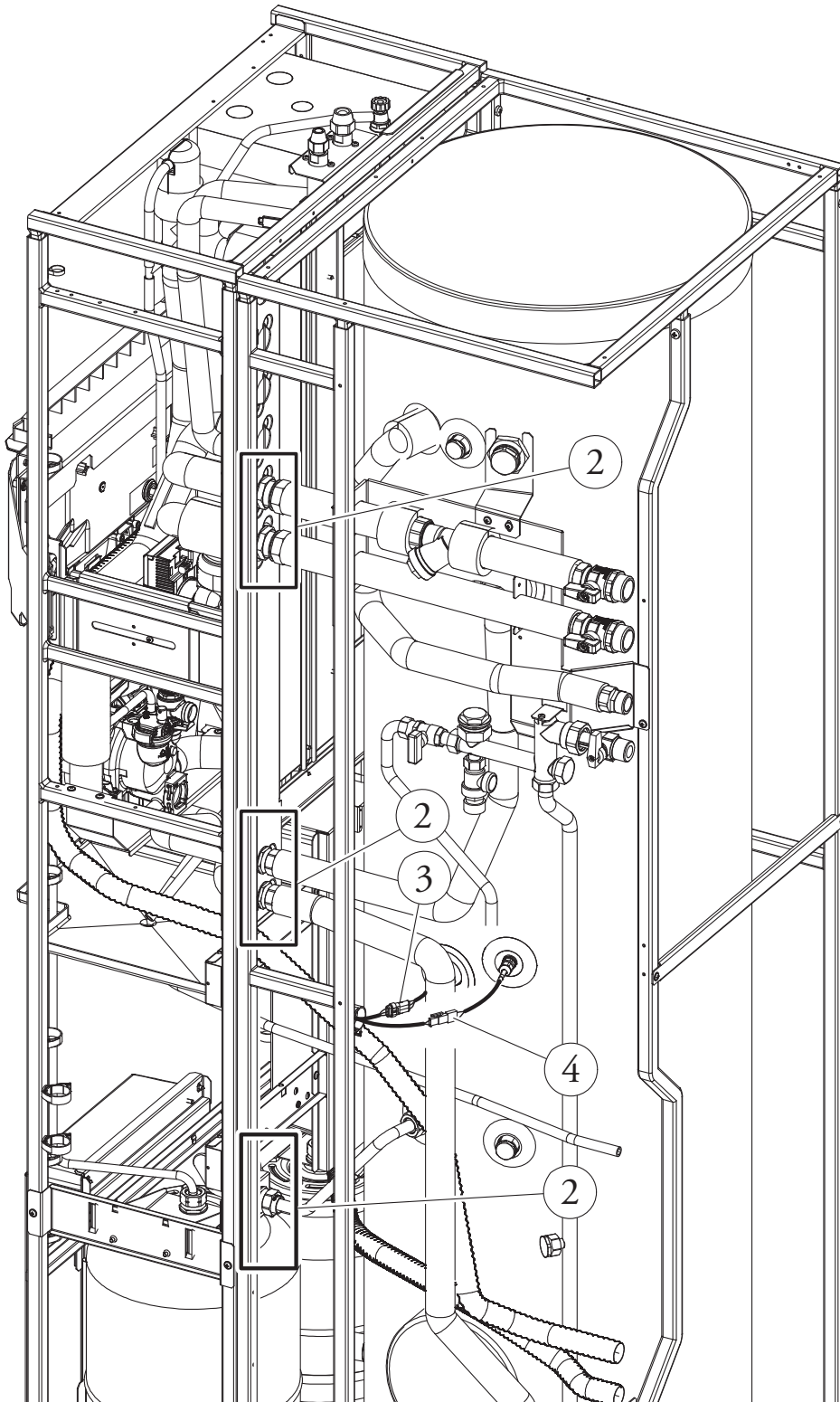

INSTALLER

USER

MAINTENANCE/TECHNICIAN

TECHNICAL DATA

- Undo the frame fixing screws (5) (Fig. 58).

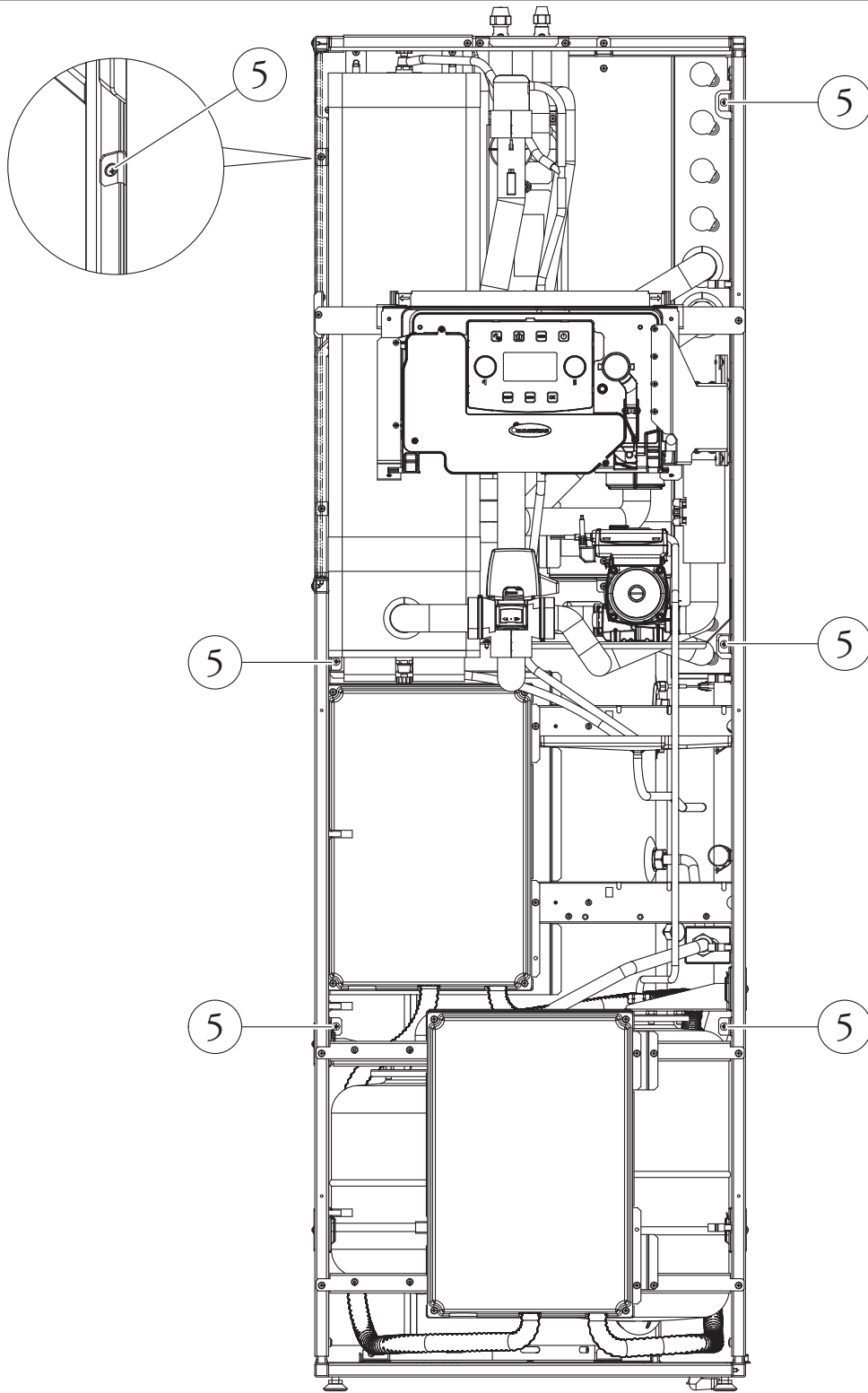

- At this point one can separate the indoor unit into two parts, be careful not to lose the gaskets (6) (Fig. 59).

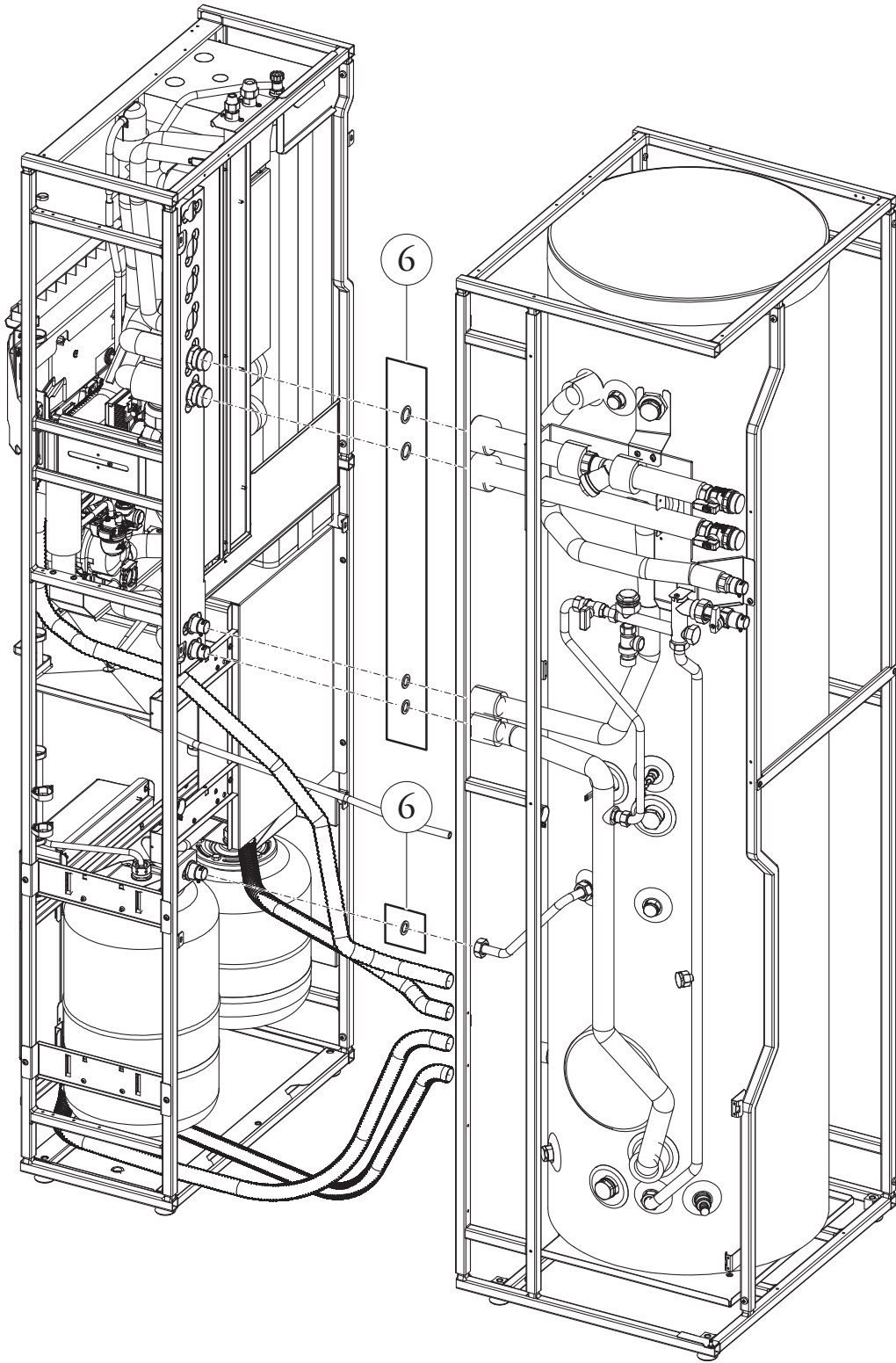

INSTALLER

USER

MAINTENANCE/TECHNICIAN

TECHNICAL DATA

4 TECHNICAL DATA

4.1 TECHNICAL DATA TABLE

The following data refers to product data.

		MAGISHERCULES PRO 4	MAGISHERCULES PRO 6	MAGISHERCULES PRO 9
Nominal data for low temperature applications (A7/W35)*				
Nominal central heating output	kW	4,40	6,00	9,00
Absorption	kW	0,85	1,22	1,87
COP	kW/kW	5,2	4,92	4,81
Nominal data for low temperature applications (A35/W18)*				
Nominal cooling output	kW	5,00	6,50	8,70
Absorption	kW	1,09	1,47	2,11
EER	kW/kW	4,59	4,42	4,12
Nominal data for intermediate temperature applications (A7/W45)**				
Nominal central heating output	kW	4,20	5,40	8,60
Absorption	kW	1,03	1,51	2,33
COP	kW/kW	4,08	3,58	3,69
Nominal data for intermediate temperature applications (A35/W7)**				
Nominal cooling output	kW	3,60	4,70	6,50
Absorption	kW	1,11	1,44	1,95
EER	kW/kW	3,24	3,26	3,33
Nominal data for medium temperature applications (A7/W55)***				
Nominal central heating output	kW	3,90	4,80	8,00
Absorption	kW	1,32	1,81	2,73
COP	kW/kW	2,95	2,65	2,93

* Central heating mode status: heat exchanger water inlet/remains at 30 °C/35 °C, outdoor air temperature 7 °C db/6 °C wb. Performance in compliance with EN 14511.

Cooling mode status: heat exchanger water inlet/remains at 23 °C/18 °C, outdoor air temperature 35 °C. Performance in compliance with EN 14511.

* Central heating mode status: heat exchanger water inlet/remains at 40 °C/45 °C, outdoor air temperature 7 °C db/6 °C wb.

Cooling mode status: heat exchanger water inlet/remains at 12 °C/7 °C, outdoor air temperature 35 °C. Performance in compliance with EN 14511.

INSTALLER

USER

MAINTENANCE TECHNICIAN

TECHNICAL DATA

Indoor Unit data

		UIMHP4	UIMHP6	UIMHP9
Dimensions (Width x Height x Depth)	mm	650x1970x908		
Water content	l	56,0		
System expansion vessel volume	l	24		
System expansion vessel pre-charged pressure	bar	1		
Hydraulic circuit max. operating pressure	kPa	300		
Domestic hot water circuit min. dynamic pressure	kPa	30		
Domestic hot water circuit pressure	kPa	800		
DHW (Domestic hot water) expansion vessel volume	l	16		
DHW expansion vessel pre-charged pressure	bar	3		
Storage tank water content	l	235		
Electrical connection	V/Hz	1P, 230Vac, 50Hz		
Absorption without additional loads	W	135		
Electrical resistance absorption	W	2300		
System integrative resistance absorption (optional)	W	6000		
EEI value	-	≤0,20 - Part. 3		
Equipment electrical system protection	-	IPX5D		
Ambient temperature range of indoor unit in summer mode	°C	-		
Ambient temperature range of indoor unit in winter mode	°C	-		
Empty indoor unit weight	kg	211		
Full indoor unit weight	kg	496		

Product data

		MAGISHERCULES PRO 4	MAGISHERCULES PRO 6	MAGISHERCULES PRO 9
Maximum heating temperature	°C	65		
Adjustable central heating temperature (max operating field)	°C	20-65		
Cooling adjustable temperature (max. operating field)	°C	5-25		
Minimum circulation flow rate	l/h	-		
Head available with 1000l/h flow rate	kPa	55		
Head available with 2000l/h flow rate	kPa	19		
Domestic hot water adjustable temperature	°C	10-55		
Domestic hot water adjustable temperature with DHW integration resistance	°C	10-65		
Room temperature in cooling mode	°C	10.. 46		
Room temperature in central heating mode	°C	-25.. 35		
Domestic hot water room temperature	°C	-25.. 35		
Domestic hot water room temperature with DHW integration resistance	°C	-25.. 46		



INSTALLER

USER

MAINTENANCE TECHNICIAN

TECHNICAL DATA

4.2 KEY FOR DATA NAMEPLATE

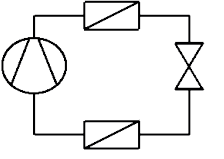
Md.	Cod.Md.	Sr N°	CHK
T.A.			
 	MPa Max.		GWP PS HI PS LO

60

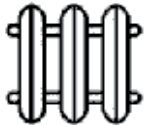
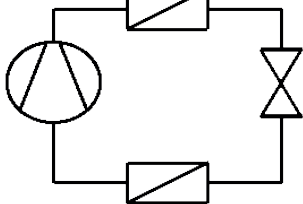

The technical data are provided on the data plate on the appliance.

	ENG
Md.	Model
Code Md.	Model code
Sr N°	Serial Number
CHK	Check
T.A.	Minimum and maximum installation room temperature
 	Achievable temperatures for Cooling and Heating respectively (Minimum and maximum system temperature)
MPa Max.	Maximum water circuit pressure
	Heat pump circuit representation
GWP	Global warming potential of the refrigerant gas versus carbon dioxide
PSHI	Maximum operating pressure of refrigerant gas
PSLO	Minimum operating pressure of refrigerant gas

4.3 MAGIS HERCULES PRO 4 PRODUCT FICHE (IN COMPLIANCE WITH REGULATION 811/2013)

A	Supplier's name or trademark	-	Immergas S.p.A	
B	Supplier's model identifier	-	MAGIS HERCULES PRO 4	
C	For space heating	Application temperature	-	Average temperature
	For water heating	Stated load profile	-	L
D	Seasonal energy efficiency class of room heating	Average temperature	-	A++
		Low temperature	-	A+++
	Energy efficiency class of water heating	-	A++	
E	Nominal heat output (average climate condition)	Average temperature	kW	5
		Low temperature	kW	5
F	Annual energy consumption for room heating (average climate condition)	Average temperature	kWh	3231
		Low temperature	kWh	2305
	Annual energy consumption for water heating (average climate condition)	kWh	912	
G	Seasonal energy efficiency of room heating (average climate condition)	Average temperature	%	125
		Low temperature	%	176
	Energy efficiency of water heating (average climate condition)	%	112	
H	Lwa sound power level indoors	dB	39	
I	Operation only during dead hours	-	No	
J	Specific precautions	-	-	
K	Nominal heat output (colder climate condition)	Average temperature	kW	4
		Low temperature	kW	4
	Nominal heat output (warmer climate condition)	Average temperature	kW	5
		Low temperature	kW	5
L	Annual energy consumption for room heating (colder climate condition)	Average temperature	kWh	4099
		Low temperature	kWh	2835
	Annual energy consumption for room heating (warmer climate condition)	Average temperature	kWh	1785
		Low temperature	kWh	1146
	Annual energy consumption for water heating (colder climate condition)	kWh	-	
Annual energy consumption for water heating (warmer climate condition)	kWh	-		
M	Seasonal energy efficiency of room heating (colder climate condition)	Average temperature	%	93
		Low temperature	%	136
	Seasonal energy efficiency of room heating (warmer climate condition)	Average temperature	%	147
		Low temperature	%	230
N	Lwa sound power level outdoors	dB	58	

INSTALLER

USER

MAINTENANCE TECHNICIAN

TECHNICAL DATA

4.4 TABLE 2 REGULATION 813/2013

Model		MAGISHERCULES PRO 4					
Air/water heat pump	yes	Low temperature heat pump				no	
Water/water heat pump	no	With Supplementary heater				no	
Brine/water heat pump	no	Mixed central heating device with heat pump:				yes	
The parameters are declared for average temperature application, except for low temperature heat pumps. The parameters for low temperature heat pumps are declared for low temperature application							
The parameters are declared for average climatic conditions							
Element	Symbol	Value	Unit	Element	Symbol	Value	Unit
Nominal heat output	$P_{nomi-nale}$	5	kW	Room central heating seasonal energy efficiency	η_s	125	%
Central heating capacity declared with a partial load and indoor temperature equivalent to 20°C and outdoor temperature T_j				Performance coefficient declared with indoor temperature equivalent to 20°C and outdoor temperature T_j			
$T_j = -7\text{ °C}$	P_{dh}	4,4	kW	$T_j = -7\text{ °C}$	COP_d	2,05	-
$T_j = +2\text{ °C}$	P_{dh}	2,7	kW	$T_j = +2\text{ °C}$	COP_d	3,05	-
$T_j = +7\text{ °C}$	P_{dh}	1,7	kW	$T_j = +7\text{ °C}$	COP_d	4,41	-
$T_j = +12\text{ °C}$	P_{dh}	1,9	kW	$T_j = +12\text{ °C}$	COP_d	5,69	-
$T_j = \text{bivalent temperature}$	P_{dh}	4,4	kW	$T_j = \text{bivalent temperature}$	COP_d	2,05	-
$T_j = \text{operating limit temperature}$	P_{dh}	4,2	kW	$T_j = \text{operating limit temperature}$	COP_d	1,49	-
for air/water heat pumps: $T_j = -15\text{ °C}$ (se TOL < -20 °C)	P_{dh}	-	kW	for air/water heat pumps: $T_j = -15\text{ °C}$ (se TOL < -20 °C)	COP_d	-	-
Bivalent temperature	T_{biv}	-7	°C	For air/water heat pumps: Operating limit temperature	TOL	-10	°C
Central heating capacity cycle intervals	P_{cyc}	-	kW	Cycle intervals efficiency	COP_{cyc} o PER_{cyc}	-	-
Degradation coefficient	C_{dh}	0,9	-	Water heating temperature operating limit	WTOL	55	°C
Different mode of energy consumption from the active mode				Supplementary heater			
OFF mode	P_{OFF}	0,010	kW	Nominal heat output	P_{sup}	-	kW
Thermostat mode off	P_{TO}	0,010	kW	Type of energy supply voltage	power reduction		
Standby mode	P_{SB}	0,010	kW				
Guard heating mode	P_{CK}	0,000	kW				
Other items							
Capacity control	-	-	-	For air/water heat pumps: nominal air output to outside	-	2400	m ³ /h
Indoor/outdoor sound level	L_{WA}	39/58	dB	For water or brine/water heat pumps: nominal flow of brine or water, outdoor heat exchanger	-	-	m ³ /h
Annual energy consumption	Q_{HE}	3231	kWh or GJ				
For mixed central heating appliances with a heat pump							
Stated load profile	L			Water central heating energy efficiency	η_{wh}	112	%
Daily electrical power consumption	Q_{elec}	4,32	kWh	Daily fuel consumption	Q_{fuel}	-	kWh
Annual energy consumption	AEC	912	kWh	Annual fuel consumption	AFC	-	GJ
Contact information	Immergas S.p.A. via Cisa Figure n.95						

INSTALLER

USER

MAINTENANCE TECHNICIAN

TECHNICAL DATA

4.5 MAGIS HERCULES PRO 6 PRODUCT FICHE (IN COMPLIANCE WITH REGULATION 811/2013)

A	Supplier's name or trademark	-	Immergas S.p.A	
B	Supplier's model identifier	-	MAGIS HERCULES PRO 6	
C	For space heating	Application temperature	-	Average temperature
	For water heating	Stated load profile	-	XL
D	Seasonal energy efficiency class of room heating	Average temperature	-	A++
		Low temperature	-	A+++
	Energy efficiency class of water heating	-	A	
E	Nominal heat output (average climate condition)	Average temperature	kW	8
		Low temperature	kW	9
F	Annual energy consumption for room heating (average climate condition)	Average temperature	kWh	5174
		Low temperature	kWh	3954
	Annual energy consumption for water heating (average climate condition)	kWh	919	
G	Seasonal energy efficiency of room heating (average climate condition)	Average temperature	%	125
		Low temperature	%	175
	Energy efficiency of water heating (average climate condition)	%	103	
H	Lwa sound power level indoors	dB	39	
I	Operation only during dead hours	-	No	
J	Specific precautions	-	-	
K	Nominal heat output (colder climate condition)	Average temperature	kW	7
		Low temperature	kW	8
	Nominal heat output (warmer climate condition)	Average temperature	kW	8
		Low temperature	kW	9
L	Annual energy consumption for room heating (colder climate condition)	Average temperature	kWh	7402
		Low temperature	kWh	5308
	Annual energy consumption for room heating (warmer climate condition)	Average temperature	kWh	2761
		Low temperature	kWh	1895
	Annual energy consumption for water heating (colder climate condition)	kWh	-	
Annual energy consumption for water heating (warmer climate condition)	kWh	-		
M	Seasonal energy efficiency of room heating (colder climate condition)	Average temperature	%	89
		Low temperature	%	137
	Seasonal energy efficiency of room heating (warmer climate condition)	Average temperature	%	147
		Low temperature	%	232
N	Lwa sound power level outdoors	dB	64	

INSTALLER

USER

MAINTENANCE TECHNICIAN

TECHNICAL DATA

4.6 TABLE 2 REGULATION 813/2013

Model		MAGISHERCULES PRO 6					
Air/water heat pump	yes	Low temperature heat pump				no	
Water/water heat pump	no	With Supplementary heater				no	
Brine/water heat pump	no	Mixed central heating device with heat pump:				yes	
The parameters are declared for average temperature application, except for low temperature heat pumps. The parameters for low temperature heat pumps are declared for low temperature application							
The parameters are declared for average climatic conditions							
Element	Symbol	Value	Unit	Element	Symbol	Value	Unit
Nominal heat output	$P_{nomi-nale}$	6	kW	Room central heating seasonal energy efficiency	η_s	125	%
Central heating capacity declared with a partial load and indoor temperature equivalent to 20°C and outdoor temperature T_j				Performance coefficient declared with indoor temperature equivalent to 20°C and outdoor temperature T_j			
$T_j = -7\text{ °C}$	P_{dh}	5,3	kW	$T_j = -7\text{ °C}$	COP_d	1,89	-
$T_j = +2\text{ °C}$	P_{dh}	3,2	kW	$T_j = +2\text{ °C}$	COP_d	3,10	-
$T_j = +7\text{ °C}$	P_{dh}	2,1	kW	$T_j = +7\text{ °C}$	COP_d	4,40	-
$T_j = +12\text{ °C}$	P_{dh}	1,9	kW	$T_j = +12\text{ °C}$	COP_d	5,69	-
$T_j = \text{bivalent temperature}$	P_{dh}	5,3	kW	$T_j = \text{bivalent temperature}$	COP_d	1,89	-
$T_j = \text{operating limit temperature}$	P_{dh}	5,0	kW	$T_j = \text{operating limit temperature}$	COP_d	1,70	-
for air/water heat pumps: $T_j = -15\text{ °C}$ (se TOL < -20 °C)	P_{dh}	-	kW	for air/water heat pumps: $T_j = -15\text{ °C}$ (se TOL < -20 °C)	COP_d	-	-
Bivalent temperature	T_{biv}	-7	°C	For air/water heat pumps: Operating limit temperature	TOL	-10	°C
Central heating capacity cycle intervals	P_{cyc}	-	kW	Cycle intervals efficiency	COP_{cyc} o PER_{cyc}	-	-
Degradation coefficient	C_{dh}	0,9	-	Water heating temperature operating limit	WTOL	55	°C
Different mode of energy consumption from the active mode				Supplementary heater			
OFF mode	P_{OFF}	0,010	kW	Nominal heat output	P_{sup}	-	kW
Thermostat mode off	P_{TO}	0,010	kW	Type of energy supply voltage	power reduction		
Standby mode	P_{SB}	0,010	kW				
Guard heating mode	P_{CK}	0,000	kW				
Other items							
Capacity control	-	-	-	For air/water heat pumps: nominal air output to outside	-	2580	m ³ /h
Indoor/outdoor sound level	L_{WA}	39/64	dB	For water or brine/water heat pumps: nominal flow of brine or water, outdoor heat exchanger	-	-	m ³ /h
Annual energy consumption	Q_{HE}	3879	kWh or GJ				
For mixed central heating appliances with a heat pump							
Stated load profile	L	-	-	Water central heating energy efficiency	η_{wh}	111	%
Daily electrical power consumption	Q_{elec}	4,35	kWh	Daily fuel consumption	Q_{fuel}	-	kWh
Annual energy consumption	AEC	919	kWh	Annual fuel consumption	AFC	-	GJ
Contact information	Immergas S.p.A. via Cisa Figure n.95						

INSTALLER

USER

MAINTENANCE TECHNICIAN

TECHNICAL DATA

4.7 MAGIS HERCULES PRO 9 PRODUCT FICHE (IN COMPLIANCE WITH REGULATION 811/2013)

A	Supplier's name or trademark		-	Immergas S.p.A
B	Supplier's model identifier		-	MAGIS HERCULES PRO 9
C	For space heating	Application temperature	-	Average temperature
	For water heating	Stated load profile	-	XL
D	Seasonal energy efficiency class of room heating	Average temperature	-	A++
		Low temperature	-	A+++
	Energy efficiency class of water heating		-	A
E	Nominal heat output (average climate condition)	Average temperature	kW	8
		Low temperature	kW	9
F	Annual energy consumption for room heating (average climate condition)	Average temperature	kWh	5174
		Low temperature	kWh	3954
	Annual energy consumption for water heating (average climate condition)		kWh	1620
G	Seasonal energy efficiency of room heating (average climate condition)	Average temperature	%	125
		Low temperature	%	175
	Energy efficiency of water heating (average climate condition)		%	103
H	Lwa sound power level indoors		dB	39
I	Operation only during dead hours		-	No
J	Specific precautions		-	-
K	Nominal heat output (colder climate condition)	Average temperature	kW	7
		Low temperature	kW	8
	Nominal heat output (warmer climate condition)	Average temperature	kW	8
		Low temperature	kW	9
L	Annual energy consumption for room heating (colder climate condition)	Average temperature	kWh	7402
		Low temperature	kWh	5308
	Annual energy consumption for room heating (warmer climate condition)	Average temperature	kWh	2761
		Low temperature	kWh	1895
	Annual energy consumption for water heating (colder climate condition)		kWh	-
Annual energy consumption for water heating (warmer climate condition)		kWh	-	
M	Seasonal energy efficiency of room heating (colder climate condition)	Average temperature	%	90
		Low temperature	%	136
	Seasonal energy efficiency of room heating (warmer climate condition)	Average temperature	%	152
		Low temperature	%	237
N	Lwa sound power level outdoors		dB	64

INSTALLER

USER

MAINTENANCE TECHNICIAN

TECHNICAL DATA

4.8 TABLE 2 REGULATION 813/2013

Model		MAGISHERCULESPRO 9					
Air/water heat pump	yes	Low temperature heat pump				no	
Water/water heat pump	no	With Supplementary heater				no	
Brine/water heat pump	no	Mixed central heating device with heat pump:				yes	
The parameters are declared for average temperature application, except for low temperature heat pumps. The parameters for low temperature heat pumps are declared for low temperature application							
The parameters are declared for average climatic conditions							
Element	Symbol	Value	Unit	Element	Symbol	Value	Unit
Nominal heat output	$P_{nomi-nale}$	8	kW	Room central heating seasonal energy efficiency	η_s	125	%
Central heating capacity declared with a partial load and indoor temperature equivalent to 20°C and outdoor temperature T_j				Performance coefficient declared with indoor temperature equivalent to 20°C and outdoor temperature T_j			
$T_j = -7\text{ °C}$	P_{dh}	7,1	kW	$T_j = -7\text{ °C}$	COP_d	1,70	-
$T_j = +2\text{ °C}$	P_{dh}	4,3	kW	$T_j = +2\text{ °C}$	COP_d	3,19	-
$T_j = +7\text{ °C}$	P_{dh}	2,8	kW	$T_j = +7\text{ °C}$	COP_d	4,60	-
$T_j = +12\text{ °C}$	P_{dh}	2,6	kW	$T_j = +12\text{ °C}$	COP_d	5,81	-
$T_j = \text{bivalent temperature}$	P_{dh}	4,9	kW	$T_j = \text{bivalent temperature}$	COP_d	1,35	-
$T_j = \text{operating limit temperature}$	P_{dh}	4,9	kW	$T_j = \text{operating limit temperature}$	COP_d	1,32	-
for air/water heat pumps: $T_j = -15\text{ °C}$ (se TOL < -20 °C)	P_{dh}	-	kW	for air/water heat pumps: $T_j = -15\text{ °C}$ (se TOL < -20 °C)	COP_d	-	-
Bivalent temperature	T_{biv}	-7	°C	For air/water heat pumps: Operating limit temperature	TOL	-10	°C
Central heating capacity cycle intervals	P_{cyc}	-	kW	Cycle intervals efficiency	COP_{cyc} o PER_{cyc}	-	-
Degradation coefficient	C_{dh}	0,9	-	Water heating temperature operating limit	WTOL	55	°C
Different mode of energy consumption from the active mode				Supplementary heater			
OFF mode	P_{OFF}	0,010	kW	Nominal heat output	P_{sup}	-	kW
Thermostat mode off	P_{TO}	0,010	kW	Type of energy supply voltage	power reduction		
Standby mode	P_{SB}	0,010	kW				
Guard heating mode	P_{CK}	0,000	kW				
Other items							
Capacity control	-	-	-	For air/water heat pumps: nominal air output to outside	-	3960	m ³ /h
Indoor/outdoor sound level	L_{WA}	39/64	dB	For water or brine/water heat pumps: nominal flow of brine or water, outdoor heat exchanger	-	-	m ³ /h
Annual energy consumption	Q_{HE}	5174	kWh or GJ		-	-	-
For mixed central heating appliances with a heat pump							
Stated load profile	XL			Water central heating energy efficiency	η_{wh}	103	%
Daily electrical power consumption	Q_{elec}	7,64	kWh	Daily fuel consumption	Q_{fuel}	-	kWh
Annual energy consumption	AEC	1620	kWh	Annual fuel consumption	AFC	-	GJ
Contact information	Immergas S.p.A. via Cisa Figure n.95						

INSTALLER

USER

MAINTENANCE TECHNICIAN

TECHNICAL DATA

4.9 PARAMETERS FOR FILLING IN THE PACKAGE FICHE

Should you wish to install an assembly starting from the Magis Hercules Pro package, use the package fiche shown in (Fig. 62). To fill it in correctly, enter the figures shown in tables in par. "Parameters to fill in the low temperature package fiche (30/35)", "Parameters to fill in the average temperature package fiche (47/55)" (as shown in the package fiche facsimile Fig. 61). The remaining values must be obtained from the technical data sheets of the products used to make up the assembly (e.g. solar devices, integration heat pumps, temperature controllers). Use board (Fig. 62) for "assemblies" related to the central heating mode (e.g.: heat pump + temperature controller).



Since the product is standard supplied with a temperature controller, the package fiche must always be completed.

Facsimile for filling in the package fiche for room central heating systems.

Room central heating seasonal energy efficiency of the heat pump

%

Temperature control
From temperature
control board

Class I = 1 %, Class II = 2 %,
Class III = 1.5 %, Class IV = 2 %,
Class V = 3 %, Class VI = 4 %,
Class VII = 3.5 %, Class VIII = 5 %

+ %

Supplementary boiler
From boiler board

Seasonal central heating energy efficiency of the room (%)

(- 'I') x "II" = - %

Solar contribution

From the board of the solar device

Dimensions of the manifold (in m²)

Volume of the tank (in m³)

Efficiency of the manifold (in %)

Classification of the tank
A* = 0.95, A = 0.91,
B = 0.86, C = 0.83,
D-G = 0.81

('III' x + 'IV' x) x 0.45 x (/ 100) x = + %

Room central heating seasonal energy efficiency of the assemble in average climate conditions

%

Room central heating seasonal energy efficiency class of the assemble in average climate conditions

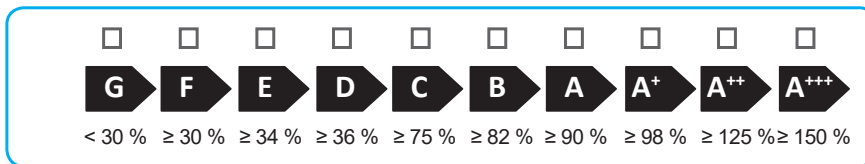

Room central heating seasonal energy efficiency in colder and hotter climate conditions

Colder: - 'V' = %

Hotter: + 'VI' = %

The energy efficiency of the set of products indicated in this sheet may not reflect the actual energy efficiency after installation since such efficiency is affected by additional factors, such as the heat loss in the distribution system and the size of the products compared to the size and features of the building.

Parameters to fill in the low temperature package fiche (30/35)

Magis Hercules PRO 4

Parameter	Colder zones	Average zones	Hotter zones
	■	■	■
"I"	136	176	230
"II"	*	*	*
"III"	6,68	5,35	5,35
"IV"	2,61	2,09	2,09

Magis Hercules PRO 6

Parameter	Colder zones	Average zones	Hotter zones
	■	■	■
"I"	137	176	232
"II"	*	*	*
"III"	5,57	4,45	4,77
"IV"	2,18	1,74	1,87

Magis Hercules PRO 9

Parameter	Colder zones	Average zones	Hotter zones
	■	■	■
"I"	136	175	237
"II"	*	*	*
"III"	3,56	3,14	3,14
"IV"	1,39	1,23	1,23

Parameters to fill in the average temperature package fiche (47/55)

Magis Hercules PRO 4

Parameter	Colder zones	Average zones	Hotter zones
	■	■	■
"I"	93	125	147
"II"	*	*	*
"III"	6,68	5,35	5,35
"IV"	2,61	2,09	2,09

Magis Hercules PRO 6

Parameter	Colder zones	Average zones	Hotter zones
	■	■	■
"I"	89	125	147
"II"	*	*	*
"III"	5,57	4,45	4,77
"IV"	2,18	1,74	1,87

Magis Hercules PRO 9

Parameter	Colder zones	Average zones	Hotter zones
	■	■	■
"I"	90	125	152
"II"	*	*	*
"III"	3,82	3,34	3,34
"IV"	1,49	1,31	1,31

* to be determined according to Regulation 811/2013 and transient calculation methods as per Notice of the European Community no. 207/2014.

Room central heating system package fiche.

Room central heating seasonal energy efficiency of the heat pump

%

Temperature control
From temperature
control board

Class I = 1 %, Class II = 2 %,
Class III = 1.5 %, Class IV = 2 %,
Class V = 3 %, Class VI = 4 %,
Class VII = 3.5 %, Class VIII = 5 %

+ %

Supplementary boiler
From boiler board

Seasonal central heating energy efficiency of the room (%)

(-) x = - %

Solar contribution

From the board of the solar device

Dimensions of the manifold (in m²)

Volume of the tank (in m³)

Efficiency of the manifold (in %)

Classification of the tank
A* = 0.95, A = 0.91,
B = 0.86, C = 0.83,
D-G = 0.81

(x + x) x 0.45 x (/ 100) x = + %

Room central heating seasonal energy efficiency of the assemble in average climate conditions

%

Room central heating seasonal energy efficiency class of the assemble in average climate conditions

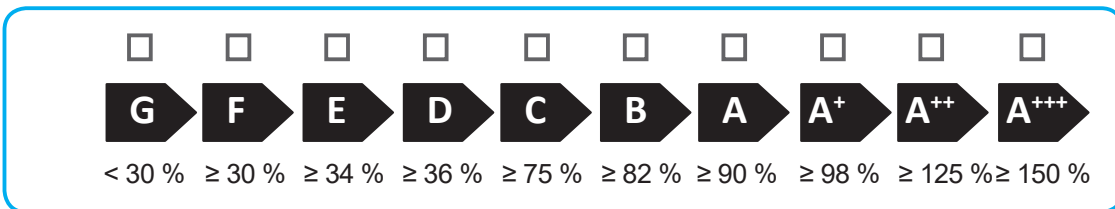

Room central heating seasonal energy efficiency in colder and hotter climate conditions

Colder: - = %

Hotter: + = %

The energy efficiency of the set of products indicated in this sheet may not reflect the actual energy efficiency after installation since such efficiency is affected by additional factors, such as the heat loss in the distribution system and the size of the products compared to the size and features of the building.

INSTALLER

USER

MAINTENANCE TECHNICIAN

TECHNICAL DATA



This instruction booklet is made of ecological paper.

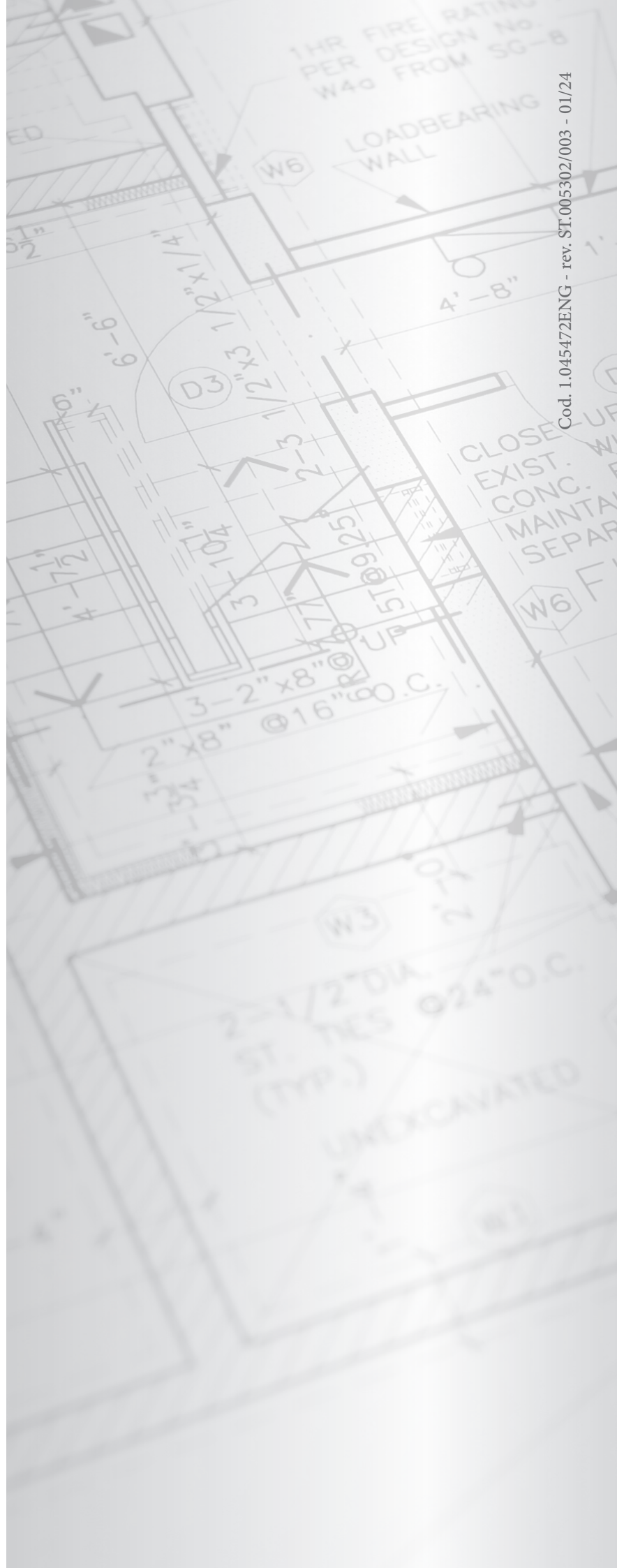

Cod. 1.045472ENG - rev. ST.005302/003 - 01/24



immergas.com

Immergas S.p.A.
42041 Brescello (RE) - Italy
Tel. 0522.689011
Fax 0522.680617